

Е

Фрезерование

Фрезерование является одним из самых актуальных вопросов металлообработки. Компания Korloy Inc постоянно работает над созданием высококачественного инструмента, который обеспечит максимальную производительность обработки с минимальными затратами.

С О Д Е Р Ж А Н И Е

Фрезерные СМП

- E 02** Система обозначения фрезерных СМП по ISO
- E 04** Фрезерные СМП
- E 25** Сборные фрезы
- E 31** Концевые сборные фрезы
- E 33** Модульные системы концевых фрез

Торцевые фрезы

- E 34** Mill-max(ISO)
Mill-max Plus (E35, E41)
- E 44** Turbo Mill
- E 47** Double Mill
- E 49** Технические характеристики фрез серии «Power Buster»
- E 52** Power Buster
- E 54** Технические характеристики фрез серии «Rich Mill»
- E 60** Rich Mill
- E 77** Технические характеристики фрез серии «Aero Mill / Aero Mill-Mini»
- E 79** Aero Mill
- E 81** Aero Mill-Mini
- E 82** PCD резак лица

Фрезы для обработки пресс форм

- E83** Технические характеристики фрез серии «Alpha Mill»
- E88** Alpha Mill
- E115** Технические характеристики фрез с хвостовиком BT/HSK
- E116** Концевые сборные фрезы с хвостовиком BT
- E119** Концевые сборные фрезы с хвостовиком HSK
- E122** Кукурузные сборные фрезы с хвостовиком BT
- E126** Кукурузные сборные фрезы с хвостовиком HSK
- E130** Модульные оправки BT
- E131** Модульные оправки HSK
- E132** Технические характеристики фрез серии «Future Mill»
- E142** Future Mill
- E166** Технические характеристики фрез серии «HRMDouble»
- E171** HRMDouble
- E181** HRM
- E186** Tank Mill
- E187** Технические характеристики фрез серии «Laser Mill / GBE / BRE»
- E194** Laser Mill



рование

Фрезы для обработки пресс форм

- E199** BFE
- E200** GBE
- E202** BRE
- E203** O-Ring Cutter
- E205** Технические характеристики фасочных фрез
- E213** Фрезы для обработки T-образных пазов

Фрезы для обработки алюминия

- E214** Технические характеристики фрез серии «Pro-L Mill»
- E217** Pro-L Mill
- E220** Технические характеристики фрез серии «Pro-A mill / Pro-X mill»
- E224** Pro-A Mill
- E227** Pro-X Mill
- E232** Концевые сборные фрезы с хвостовиком HSK
- E233** Оправки для сменных фрезерных головок (MAT)

Дисковые сборные фрезы

- E235** Технические характеристики дисковых прорезных регулируемых фрез
- E237** Дисковые прорезные регулируемые фрезы
- E241** Дисковые сборные фрезы
- E246** Технические характеристики инструмента серии «Wind Mill»
- E248** Wind Mill

Торцевые высокопроизводительные сборные фрезы

- E250** Технические характеристики фрез серии «Торцевые высокопроизводительные фрезы для обработки чугуна, Storm Mill Shave Mill Ultra, Cube Mill Couple Mill»
- E259** Торцевые высокопроизводительные фрезы для обработки чугуна
- E267** Shave Mill
- E268** Shave Mill Ultra

Геометрические характеристики присоединительных размеров

- E270** Присоединительные размеры торцевых фрез

Модульные фрезы

- E273** Технические характеристики модульных дисковых сборных фрез
- E274** Стандартные типы модульных дисковых сборных фрез
- E275** Модульные дисковые сборные фрезы
- E383** Форма технического задания для заказа нестандартных модульных фрез
- E384** Сменные НОВ
- E385** Бланк заказа червячной фрезы со сменными пластинами

Система обозначения фрезерных СМП по ISO

S

1

Форма СМП

P

2

Задний угол

K

3

Класс точности

R

4

Тип СМП

12

5

Длина режущей кромки, диаметр вписанной окружности

1 Форма СМП

S P K R 12 03 ^{ED} 08 S R - M X

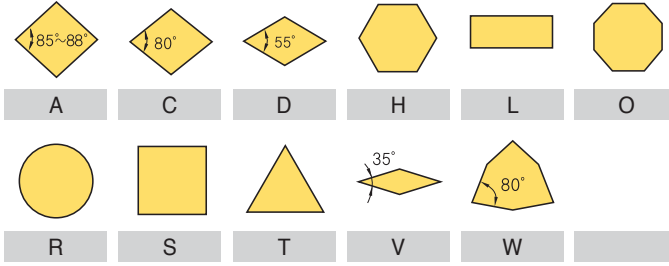

2 Задний угол

S P K R 12 03 ^{ED} 08 S R - M X

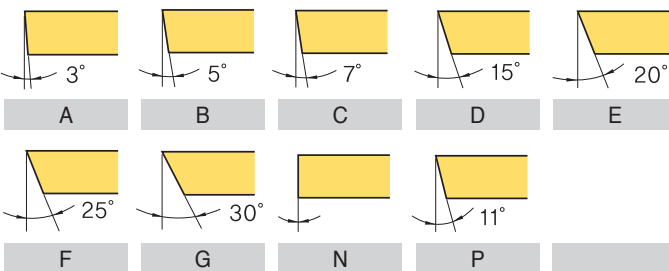

3 Класс точности

S P K R 12 03 ^{ED} 08 S R - M X

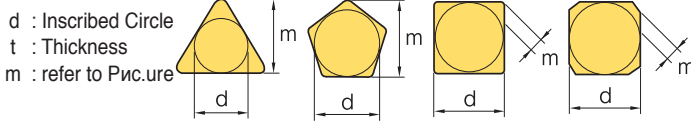

Точность пластин для форм СМП типа С, Е, Н, М, О, Р, S, Т, W

Класс	(мм)			Точность по d				Точность по m	
	d	m	t	d	J,K,L,M,N	U	M,N	U	
A	±0.025	±0.005	±0.025	6.35	±0.05	±0.08	±0.08	±0.13	
C	±0.025	±0.013	±0.025	9.525	±0.05	±0.08	±0.08	±0.13	
H	±0.013	±0.013	±0.025	12.7	±0.08	±0.13	±0.13	±0.20	
E	±0.025	±0.025	±0.025	15.875	±0.10	±0.18	±0.15	±0.27	
G	±0.025	±0.025	±0.13	19.05	±0.10	±0.18	±0.15	±0.27	
J	±0.05 ~ ±0.15	±0.005	±0.025	25.4	±0.13	±0.25	±0.18	±0.38	
K	±0.05 ~ ±0.15	±0.013	±0.025	Точность пластин для формы СМП типа D					
L	±0.05 ~ ±0.15	±0.025	±0.025	d	Точность по d	Точность по m			
M	±0.05 ~ ±0.15	±0.08 ~ ±0.20	±0.13	6.35	±0.05	±0.11			
U	±0.08 ~ ±0.25	±0.13 ~ ±0.38	±0.13	9.525	±0.05	±0.11			
				12.7	±0.08	±0.15			
				15.875	±0.10	±0.18			
				19.05	±0.10	±0.18			

4 Тип СМП

S P K R 12 03 ^{ED} 08 S R - M X

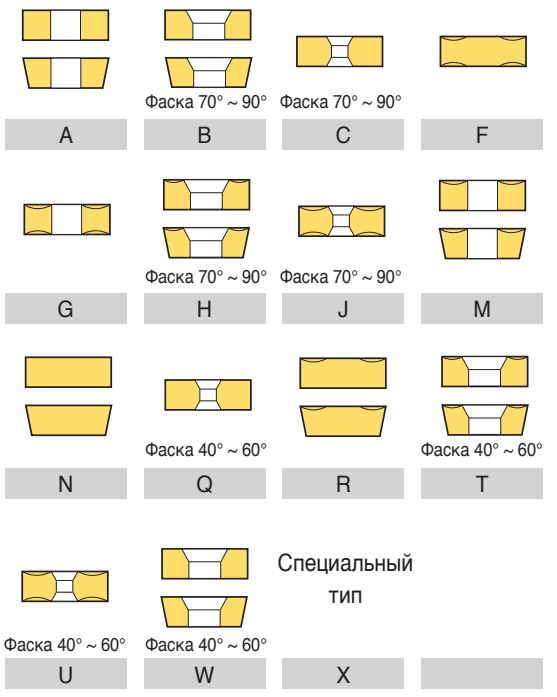

5 Длина режущей кромки, диаметр вписанной окружности

S P K R 12 03 ^{ED} 08 S R - M X

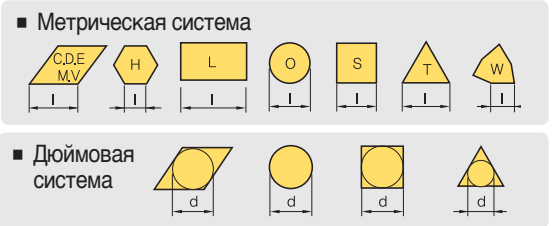

Применяется обозначение 1/32" для пластин с d вписанной окружности менее 1/4"
Применяется обозначение 1/4" для пластин с d вписанной окружности более 1/4"

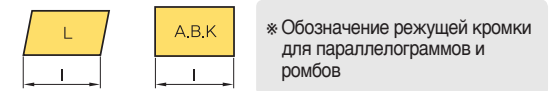

Обозначение режущей кромки для параллелограммов и ромбов

Геометрические размеры режущей кромки СМП	06	09	11	16	22	27	33	44
06	09	11	16	22	27	33	44	
03	05	06	09	12	15	19	25	
04	06	07	11	15	19	23	31	
03	05	06	09	12	16	19	25	
Диаметр вписанной окружности	5/32"	7/32"	1/4"	3/8"	1/2"	5/8"	3/4"	1"
Дюймовая система	5	7	2(8)	3	4	5	6	8



03

6

Высота СМП

ED 08

7

Радиус при вершине (R)

S

8

Геометрия режущей кромки, K

R - MX

9

Исполнение

10

Фрезерные стружколомы

6 Высота СМП

SPKR1203^{ED}₀₈SR - MX

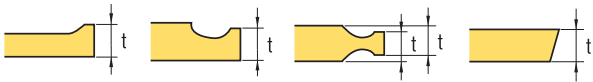

Обозначение		Высота	
Метрическое	Дюймовое	мм	Дюймовое
01	1(2)	1.59	1/16
T0	1.125	1.79	9/128
T1	1.2	1.98	5/64
02	1.5(3)	2.38	3/32
T2	1.75	2.78	7/64
03	2	3.18	1/8
T3	2.5	3.97	5/32
04	3	4.76	3/16
05	3.5	5.56	7/32
06	4	6.35	1/4
07	5	7.94	5/16
09	6	9.52	3/8
11	7	11.11	7/16
12	8(16)	12.70	1/2

() Обозначение для маленьких размеров

8 Геометрия режущей кромки, K

SPKR1203^{ED}₀₈SR - MX



9 Исполнение

SPKR1203^{ED}₀₈SR - MX

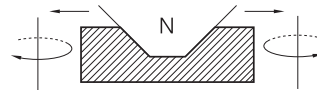
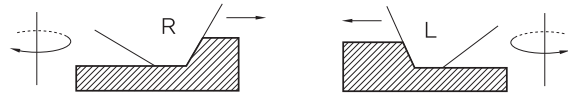

7 Радиус при вершине (R)

SPKR1203^{ED}₀₈SR - MX

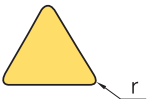

r		Обозначение		r		Обозначение	
мм	Дюйм	мм	Дюйм	мм	Дюйм	мм	Дюйм
00	0	0.0		12	3	1.2	3/64
02		0.2		15		1.5	
04	1	0.4	1/64	16	4	1.6	4/64
05		0.5		24	6	2.4	6/64
08	2	0.8	2/64	32	8	3.2	8/64
10		1.0		40		4.0	

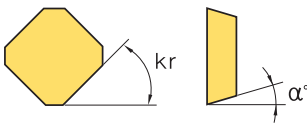

Угол в плане kr	Вспомогательный задний угол α°
A - 45°	A - 3° F - 25°
D - 60°	B - 5° G - 30°
E - 75°	C - 7° N - 0°
F - 85°	D - 15° P - 11°
P - 90°	E - 20°
Z - специальный	

10 Фрезерные стружколомы

SPKR1203^{ED}₀₈SR - MX



MA MF MM MX

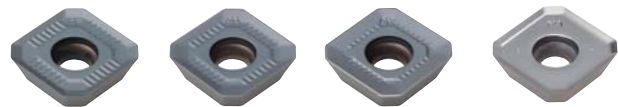

MF MM MR MA



MA MF MM



СМП	Обозначение	Твердые сплавы с покрытием											Керметы				Твердые сплавы				Размеры СМП (мм)					Геометрия	применяемые корпуса фрез, стр.																																																																																																																																							
		NCM325	NCM335	NC5330	PC3500	PC3545	PC9530	PC6510	PC215K	PD2000	CN2000	CN20	CN30	H01	G10	ST30A	ST20	l	d	t	r	d ₁																																																																																																																																												
		<p>Обрабатываемые материалы</p> <table border="1"> <tr><td>Стали</td><td>P</td><td>●</td><td>●</td><td>●</td><td>●</td><td>●</td><td>●</td><td>●</td><td>●</td><td>●</td><td>●</td><td>●</td><td>●</td><td>●</td><td>●</td><td>●</td><td>●</td><td>●</td><td>●</td><td>●</td><td>●</td></tr> <tr><td>Нержавеющие стали</td><td>M</td><td>●</td><td>●</td><td>●</td><td>●</td><td>●</td><td>●</td><td>●</td><td>●</td><td>●</td><td>●</td><td>●</td><td>●</td><td>●</td><td>●</td><td>●</td><td>●</td><td>●</td><td>●</td><td>●</td><td>●</td></tr> <tr><td>Чугуны</td><td>K</td><td>●</td><td>●</td><td>●</td><td>●</td><td>●</td><td>●</td><td>●</td><td>●</td><td>●</td><td>●</td><td>●</td><td>●</td><td>●</td><td>●</td><td>●</td><td>●</td><td>●</td><td>●</td><td>●</td><td>●</td></tr> <tr><td>Цветные металлы</td><td>N</td><td>●</td><td>●</td><td>●</td><td>●</td><td>●</td><td>●</td><td>●</td><td>●</td><td>●</td><td>●</td><td>●</td><td>●</td><td>●</td><td>●</td><td>●</td><td>●</td><td>●</td><td>●</td><td>●</td><td>●</td></tr> <tr><td>Жаропрочные сплавы, титан</td><td>S</td><td>●</td><td>●</td><td>●</td><td>●</td><td>●</td><td>●</td><td>●</td><td>●</td><td>●</td><td>●</td><td>●</td><td>●</td><td>●</td><td>●</td><td>●</td><td>●</td><td>●</td><td>●</td><td>●</td><td>●</td></tr> <tr><td>Материалы с повышенной твердостью</td><td>H</td><td>●</td><td>●</td><td>●</td><td>●</td><td>●</td><td>●</td><td>●</td><td>●</td><td>●</td><td>●</td><td>●</td><td>●</td><td>●</td><td>●</td><td>●</td><td>●</td><td>●</td><td>●</td><td>●</td><td>●</td></tr> </table>																			Стали	P	●	●	●	●	●	●	●	●	●	●	●	●	●	●	●	●	●	●	●	●	Нержавеющие стали	M	●	●	●	●	●	●	●	●	●	●	●	●	●	●	●	●	●	●	●	●	Чугуны	K	●	●	●	●	●	●	●	●	●	●	●	●	●	●	●	●	●	●	●	●	Цветные металлы	N	●	●	●	●	●	●	●	●	●	●	●	●	●	●	●	●	●	●	●	●	Жаропрочные сплавы, титан	S	●	●	●	●	●	●	●	●	●	●	●	●	●	●	●	●	●	●	●	●	Материалы с повышенной твердостью	H	●	●	●	●	●	●	●	●	●	●	●	●	●	●	●	●	●	●	●	●	Условия резания					<ul style="list-style-type: none"> ● Непрерывное ● Универсальное ● Прерывистое 				
Стали	P	●	●	●	●	●	●	●	●	●	●	●	●	●	●	●	●	●	●	●	●																																																																																																																																													
Нержавеющие стали	M	●	●	●	●	●	●	●	●	●	●	●	●	●	●	●	●	●	●	●	●																																																																																																																																													
Чугуны	K	●	●	●	●	●	●	●	●	●	●	●	●	●	●	●	●	●	●	●	●																																																																																																																																													
Цветные металлы	N	●	●	●	●	●	●	●	●	●	●	●	●	●	●	●	●	●	●	●	●																																																																																																																																													
Жаропрочные сплавы, титан	S	●	●	●	●	●	●	●	●	●	●	●	●	●	●	●	●	●	●	●	●																																																																																																																																													
Материалы с повышенной твердостью	H	●	●	●	●	●	●	●	●	●	●	●	●	●	●	●	●	●	●	●	●																																																																																																																																													
ADKA	150308R																15.0	9.525	3.18	0.8	4.5		-																																																																																																																																											
	150308SR	●															15.0	9.525	3.18	0.8	4.5																																																																																																																																													
	150308TR																15.0	9.525	3.18	0.8	4.5																																																																																																																																													
ADLT	150308R	●															15.0	9.525	3.18	0.8	4.5		E186																																																																																																																																											
	150308SR		●														15.0	9.525	3.18	0.8	4.5																																																																																																																																													
	150308TR																15.0	9.525	3.18	0.8	4.5																																																																																																																																													
APFT-X22	1604PDSR-X22			●													16.4	9.525	4.76	0.8	4.4		E92 E104																																																																																																																																											
	1604PDTR-X22																16.4	9.525	4.76	0.8	4.4																																																																																																																																													
APFT-X28	1604PDR-X28																16.4	9.525	4.76	0.8	4.4		E92 E104																																																																																																																																											
	1604PDSR-X28																16.4	9.525	4.76	0.8	4.4																																																																																																																																													
	1604PDTR-X28																16.4	9.525	4.76	0.8	4.4																																																																																																																																													
APKT	1604PDSR	●	●		●												16.4	9.525	4.76	0.8	4.4		E92 E104																																																																																																																																											
APKT-MA	1604PDFR-MA									●		●					16.4	9.525	4.76	0.2	4.4		E92 E104																																																																																																																																											
APKT-MA2	1604PDFR-MA2											●					16.5	9.56	5.76	0.8	4.5		E92 E104																																																																																																																																											
	160416FR-MA2																16.5	9.56	5.76	1.6	4.5																																																																																																																																													
	160432FR-MA2																	16.5	9.56	5.76	3.2			4.5																																																																																																																																										
APKT-MA3	1604PDFR-MA3												●	●			16.4	9.525	5.0	0.8	4.4		E92 E104																																																																																																																																											
	160420FR-MA3																16.0	9.525	5.0	2.0	4.4																																																																																																																																													
APKT-MF	1604PDSR-MF	●		●													16.4	9.525	5.0	0.8	4.4		E92 E104 E111																																																																																																																																											
APKT-MM	1604PDSR-MM	●	●	●	●	●	●										16.4	9.525	5.2	0.8	4.4		E92 E104 E111																																																																																																																																											
APKT-MM1	160432R-MM1	●															16.4	9.525	4.76	3.2	4.4		E92 E104																																																																																																																																											
APKT-X22	1604PDSR-X22	●															16.4	9.525	4.76	0.8	4.4		E92 E104																																																																																																																																											
	1604PDTR-X22																16.4	9.525	4.76	0.8	4.4																																																																																																																																													









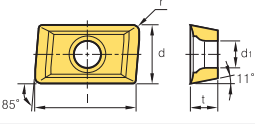

● : Наличие на складе

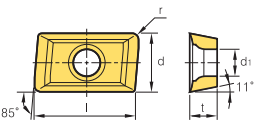

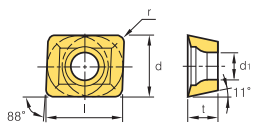
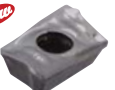
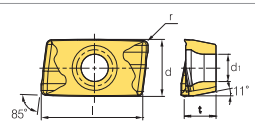
Обрабатываемые материалы	Стали	P	•	•	•	•	•	•	•	•	•	•	•	•	•	•	•	•	•	•	•	•	•	•	•
	Нержавеющие стали	M	•	•	•	•	•	•	•	•	•	•	•	•	•	•	•	•	•	•	•	•	•	•	•
	Чугуны	K	•	•	•	•	•	•	•	•	•	•	•	•	•	•	•	•	•	•	•	•	•	•	•
	Цветные металлы	N	•	•	•	•	•	•	•	•	•	•	•	•	•	•	•	•	•	•	•	•	•	•	•
	Жаропрочные сплавы, титан	S	•	•	•	•	•	•	•	•	•	•	•	•	•	•	•	•	•	•	•	•	•	•	•
Материалы с повышенной твердостью	H	•	•	•	•	•	•	•	•	•	•	•	•	•	•	•	•	•	•	•	•	•	•	•	

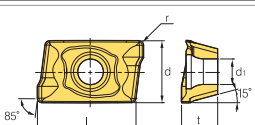
Условия резания

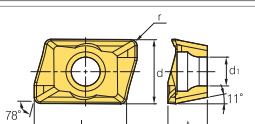
- Непрерывное
- ◐ Универсальное
- ◑ Прерывистое

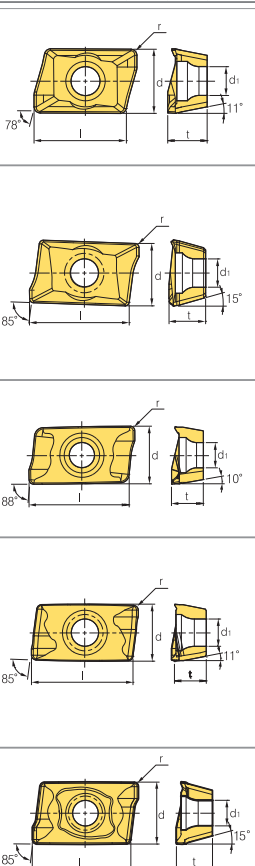
СМП	Обозначение	Твердые сплавы с покрытием												Керметы					Твердые сплавы					Размеры СМП (мм)					Геометрия	применяемые корпуса фрез, стр.
		NCM325	NCM335	NC5330	PC3500	PC5300	PC5400	PC5450	PC6510	PC6530	PD2000	CN2000	CN20	CN30	H01	G10	ST30A	ST20	l	d	t	r	d _f							
APKT-X23 	1604PDR-X23																		16.3	9.525	4.76	1.0	4.4		E92 E104					
	1604PDTR-X23																		16.3	9.525	4.76	1.0	4.4							
APKT-X24 	1604PDR-X24																		16.3	9.525	4.76	1.0	4.4		E92 E104					
	1604PDR-X24																		16.3	9.525	4.76	1.0	4.4							
APLT 	070304R																		7.5	6.35	3.18	0.4	2.8		E186					
APMT-MA 	0602PDFR-MA															●			6	4.24	2.6	0.4	2.0		E88~E91 E93, E96~E103 E105~E106 E109~E114 E116~E118 E121~E124 E126~E129					
	0903PDFR-MA															●			9.4	6.21	3.6	0.4	2.8							
	11T3PDFR-MA															●			11.2	6.467	3.6	0.5	2.9							
	1604PDFR-MA															●			16.4	9.41	5.76	0.8	4.5							
	1806PDFR-MA															●			17.4	10.98	6.35	0.8	4.5							
APMT-MF 	11T3PDSR-MF	●	●	●	●	●	●	●											11.2	6.467	3.6	0.5	2.85		E98~E114 E117, E118 E120, E121 E123, E124 E127, E128 E129					
	1604PDSR-MF	●	●	●	●	●	●	●											16.4	9.41	5.76	0.8	4.5							
	1806PDSR-MF		●	●	●	●	●	●											17.4	10.98	6.35	0.8	4.5							
	180612PDSR-MF		●	●	●	●	●	●											17.4	10.98	6.35	1.2	4.5							
APMT-ML 	0903PDER-ML							●											9.4	6.21	3.6	0.4	2.8		E89~E91, E93 E96~E98 E100~E103 E105~E106 E109~E111 E113~E114 E116~E124 E126~E129					
	11T3PDER-ML							●											11.2	6.467	3.6	0.5	2.9							
	1604PDER-ML							●											16.4	9.41	5.76	0.8	4.5							
	1806PDER-ML							●											17.4	10.98	6.35	0.8	4.5							
APMT-MM 	060202PDSR-MM	●	●	●	●	●													6	4.24	2.6	0.2	2.0		E88~E114 E116~E129					
	0602PDSR-MM	●	●	●	●	●	●	●											6	4.24	2.6	0.4	2.0							
	060208PDSR-MM	●	●	●	●	●	●												6	4.24	2.6	0.8	2.0							
	060212R-MM	●	●	●	●	●													6	4.24	2.6	1.2	2.0							
	060216R-MM	●																	6	4.24	2.6	1.6	2.0							
	0903PDSR-MM	●	●	●	●	●													9.4	6.21	3.6	0.4	2.8							
	090306PDSR-MM	●	●	●	●	●													9.4	6.21	3.6	0.6	2.8							
	090308PDSR-MM	●	●	●	●	●													9.4	6.21	3.6	0.8	2.8							
	090312R-MM	●	●	●	●	●													9.4	6.21	3.6	1.2	2.8							
	090316R-MM	●	●	●	●	●													9.4	6.21	3.6	1.6	2.8							
	090320R-MM	●	●																9.2	6.21	3.6	2.0	2.8							
	090331R-MM	●	●	●	●	●													9.2	6.21	3.6	3.1	2.8							
	090332R-MM	●	●	●	●	●													9.2	6.21	3.6	3.2	2.8							
	11T3PDSR-MM	●	●	●	●	●	●	●											11.2	6.467	3.6	0.5	2.85							
	11T308PDSR-MM	●	●	●	●	●	●	●											11.2	6.467	3.6	0.8	2.85							
	11T312PDSR-MM	●	●	●	●	●	●	●											11.2	6.467	3.6	1.2	2.85							
	11T316R-MM	●	●	●	●	●													11	6.467	3.6	1.6	2.85							
	11T318R-MM	●	●	●	●	●													11	6.467	3.6	1.8	2.85							
	11T324R-MM	●	●	●	●	●													11	6.467	3.6	2.4	2.85							
	1604PDSR-MM	●	●	●	●	●	●	●											16.4	9.41	5.76	0.8	4.5							
	160410PDSR-MM	●	●	●	●	●	●												16.4	9.41	5.76	1.0	4.5							
	160416PDSR-MM	●	●	●	●	●	●												16.4	9.41	5.76	1.6	4.5							
	160424R-MM	●	●	●	●	●													16	9.41	5.76	2.4	4.5							
	160430R-MM	●	●	●	●	●													16	9.41	5.76	3.0	4.5							
	160432R-MM	●	●	●	●	●													16	9.41	5.76	3.2	4.5							
	160450R-MM	●	●	●	●	●													16	9.41	5.76	5.0	4.5							
160464R-MM	●	●	●	●	●													16	9.41	5.76	6.4	4.5								
1806PDSR-MM	●	●	●	●	●	●	●											17.4	10.98	6.35	0.8	4.5								
180612PDSR-MM	●	●	●	●	●	●												17.4	10.98	6.35	1.2	4.5								
180616PDSR-MM	●	●	●	●	●													17.4	10.98	6.35	1.6	4.5								
180620PDSR-MM	●	●	●	●	●													17.4	10.98	6.35	2.0	4.5								
180624PDSR-MM	●	●	●	●	●													17.4	10.98	6.35	2.4	4.5								

* Маркированный вставка нет стандартного держатель, Вы должны принять заказ по специальным держателем











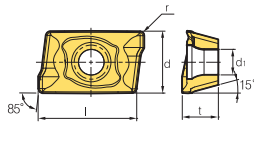

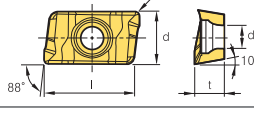

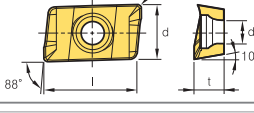

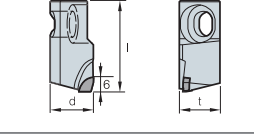
● : Наличие на складе

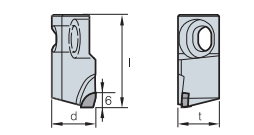
Фрезерные СМП

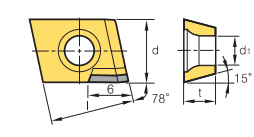
Обрабатываемые материалы	Стали	P	*	*	*	*	*	*	*	*	*	*	*	*	*	*	*	*	*	
	Нержавеющие стали																			M
Чугуны	K																			
Цветные металлы	N																			
Жаропрочные сплавы, титан	S																			
Материалы с повышенной твердостью	H																			

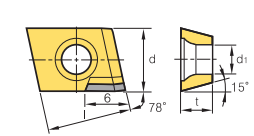
Условия резания

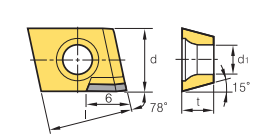
- Непрерывное
- Универсальное
- ✱ Прерывистое

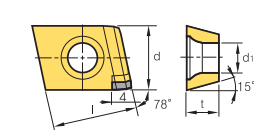
СМП	Обозначение	Твердые сплавы с покрытием											Керметы	Твердые сплавы				Размеры СМП (мм)						Геометрия	применяемые корпуса фрез, стр.	
		NCM325	NCM335	NC5330	PC3500	PC5300	PC5400	PC3545	PC9530	PD2000	CN2000	CN20		CN30	H01	G10	ST30A	PCD	DP200	l	d	t	r			d ₁
	180630R-MM																	16.7	10.98	6.35	3.0	4.5	-		E8-E114 E116-E129	
	180632R-MM	●	●															16.7	10.98	6.35	3.2	4.5	-			
	180640R-MM			●	●														16.7	10.98	6.35	4.0	4.5			-
	180648R-MM				●														16.7	10.98	6.35	4.8	4.5			-
	180650R-MM					●													16.7	10.98	6.35	5.0	4.5			-
	180660R-MM						●												16.7	10.98	6.35	6.0	4.5			-
	180664R-MM							●											16.7	10.98	6.35	6.4	4.5			-
	11T3PDR-MA												●					11.3	6.594	3.6	0.5	2.85	-		E102 E111 E114	
	11T318R-MA																	11.3	6.594	3.6	1.8	2.85	-			
	11T3PDSR-MR																	11.3	6.594	3.6	0.5	2.85	-		E107	
	11T308PDR-MR																	11.3	6.594	3.6	0.8	2.85	-			
	BAPDR-XAF																	31	14	13.8	-	-	-		E81	
	BAPDL-XAF																	31	14	13.8	-	-	-			
	BAPDR-XAW																	31	13.8	13.8	-	-	-		E81	
	BAPDL-XAW																	31	13.8	13.8	-	-	-			
	1204R-NAF															●		12.7	9.525	4.76	-	4.4	-		E80 E81	
	1204L-NAF																	12.7	9.525	4.76	-	4.4	-			
	1204R-NAW															●		12.7	9.525	4.76	-	4.4	-		E80 E81	
	1204L-NAW																	12.7	9.525	4.76	-	4.4	-			
	1204R-XAF															●		12.7	9.525	4.76	-	4.4	-		E80 E81	
	1204L-XAF																	12.7	9.525	4.76	-	4.4	-			
	1204R-XAW															●		12.7	9.525	4.76	-	4.4	-		E80 E81	
	1204L-XAW																	12.7	9.525	4.76	-	4.4	-			











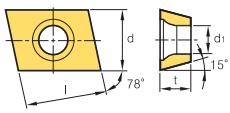

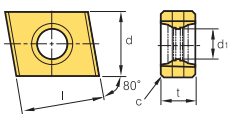

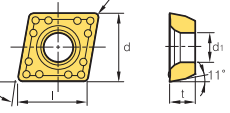
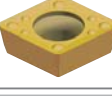
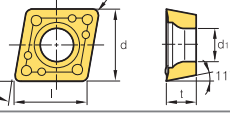

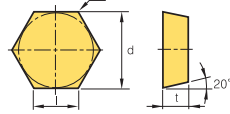

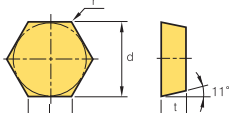

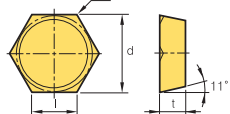
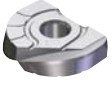
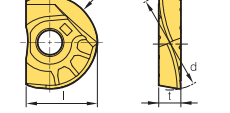

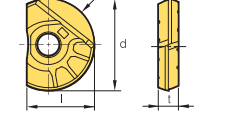

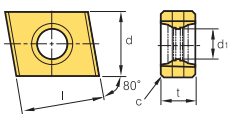

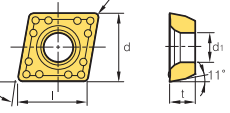
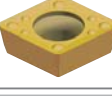
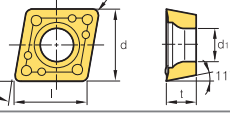

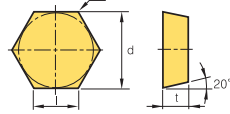

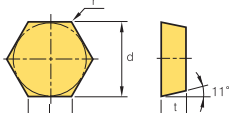

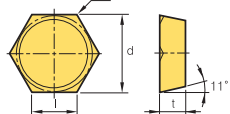
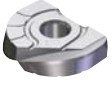
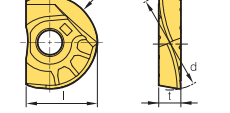

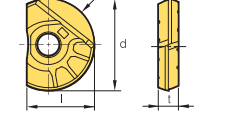

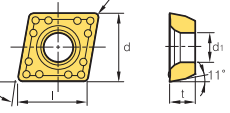
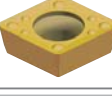
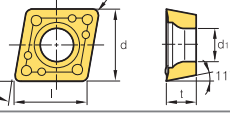

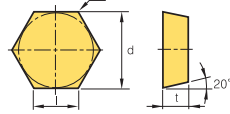

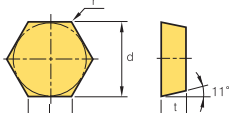

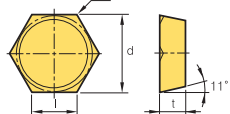
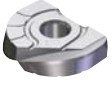
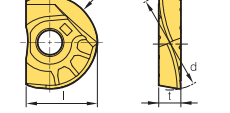

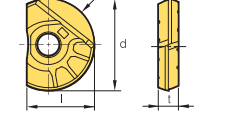

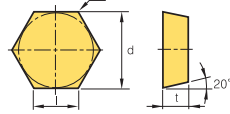

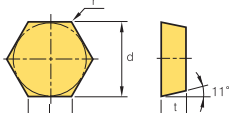

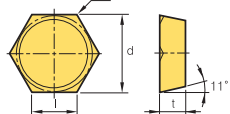
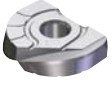
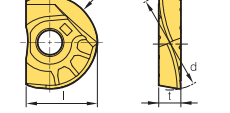

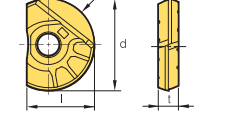

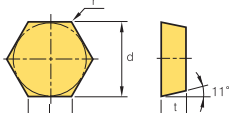

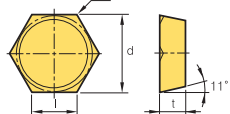
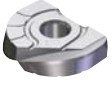
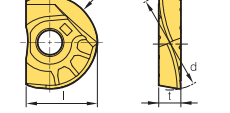
* Маркированный вставка нет стандартного держатель, Вы должны принять заказ по специальным держателем ● : Наличие на складе

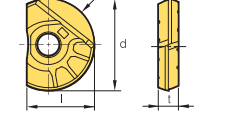

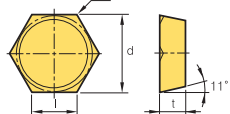
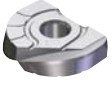
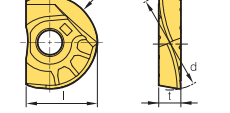
Обрабатываемые материалы	Стали	P	●	●	●	●	●	●	●	●	●	●	●	●	●
	Нержавеющие стали	M													
Чугуны	●	K	●	●	●	●	●	●	●	●	●	●	●	●	●
Цветные металлы	●	N	●	●	●	●	●	●	●	●	●	●	●	●	●
Жаропрочные сплавы, титан	●	S	●	●	●	●	●	●	●	●	●	●	●	●	●
Материалы с повышенной твердостью	●	H	●	●	●	●	●	●	●	●	●	●	●	●	●

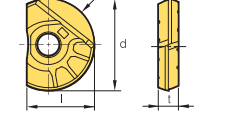
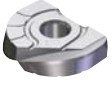
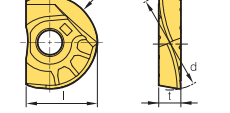
Условия резания

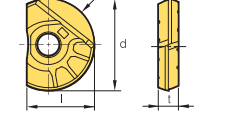
- Непрерывное
- Универсальное
- Прерывистое

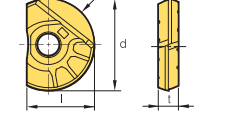
СМП	Обозначение	Твердые сплавы с покрытием		Керметы		Твердые сплавы		Размеры СМП (мм)						Геометрия	применяемые корпуса фрез, стр.																																																																																																																																																																																																																																																																																																																																																																																																																																																																																																																																																																																																																																																																																																																																																																																																																																																																																																																																																																																																																																																																																																
		NCM325	NCM335	NC5330	PC3500	PC5300	PC3545	PC9530	PC6510	PC210F	PD2000	CN2000	CN20			CN30	H01	G10	ST30A	ST20	l	d	t	r	d ₁	C																																																																																																																																																																																																																																																																																																																																																																																																																																																																																																																																																																																																																																																																																																																																																																																																																																																																																																																																																																																																																																																																																					
CDEW-XCF 	1204R-XCF																		12.7	9.525	4.76	-	4.4	-	 E80 E81																																																																																																																																																																																																																																																																																																																																																																																																																																																																																																																																																																																																																																																																																																																																																																																																																																																																																																																																																																																																																																																																																						
	1204L-XCF																		12.7	9.525	4.76	-	4.4	-		CNHQ 	1005-C0.5																		10	10	5.4	-	4.7	0.5	 E237 E238	1305-C0.5																		12.7	10	5.4	-	4.7	0.5	1606-C0.5																		16	12	6.4	-	5.9	0.5	CPMH 	120408-MM				●														12.9	12.7	4.76	0.8	5.5	-	 E213	CPMT 	060204-MM				●														6.4	6.35	2.38	0.4	2.75	-	 E213	080308-MM				●														8.1	7.938	3.40	0.8	3.18	-	09T308-MM				●														9.7	9.525	3.97	0.8	4.4	-	HECN 	090408FN																		9.0	15.875	4.76	0.8	-	-	 E263	090408SN																		9.0	15.875	4.76	0.8	-	-	090408TN																		9.0	15.875	4.76	0.8	-	-	110412FN																		11.0	19.05	4.76	1.2	-	-	110412TN																		11.0	19.05	4.76	1.2	-	-	HPEN 	090408FN																		9.0	15.875	4.76	0.8	-	-	 E263	090408SN																		9.0	15.875	4.76	0.8	-	-	090408EN																		9.0	15.875	4.76	0.8	-	-	110412FN																		11.0	19.05	4.76	1.2	-	-	HPEN-WC 	090408-WC																		9.0	15.875	4.76	0.8	-	-	 E263	110412-WC																		11.0	19.05	4.76	1.2	-	-	LBH 	080																		7.0	8	2.4	4	-	-	 E94	090																		7.5	9	2.4	4.5	-	-	100																		8.5	10	2.6	5	-	-	110																		9.0	11	2.6	5.5	-	-	120																		10.0	12	3	6	-	-	130																		10.5	13	3	6.5	-	-	160																		12.0	16	4	8	-	-	170																		12.5	17	4	8.5	-	-	200																		15.0	20	5	10	-	-	210																		15.5	21	5	10.5	-	-	250																		18.5	25	6	12.5	-	-	260																		19.0	26	6	13	-	-	300																		22.5	30	7	15	-	-	310																		23.0	31	7	15.5	-	-	320																		23.5	32	7	16	-	-	LBS 	080																		7.0	8	2.4	4	-	-	 E94	090																		7.5	9	2.4	4.5	-	-	100																		8.5	10	2.6	5	-	-	110																		9.0	11	2.6	5.5	-	-	120																		10.0	12	3	6	-	-	130																		10.5	13	3	6.5	-	-	160																		12.0	16	4	8	-	-	170																		12.5	17	4	8.5	-	-	200																		15.0	20	5	10	-	-	210																		15.5	21	5	10.5
CNHQ 	1005-C0.5																		10	10	5.4	-	4.7	0.5	 E237 E238																																																																																																																																																																																																																																																																																																																																																																																																																																																																																																																																																																																																																																																																																																																																																																																																																																																																																																																																																																																																																																																																																						
	1305-C0.5																		12.7	10	5.4	-	4.7	0.5																																																																																																																																																																																																																																																																																																																																																																																																																																																																																																																																																																																																																																																																																																																																																																																																																																																																																																																																																																																																																																																																																							
	1606-C0.5																		16	12	6.4	-	5.9	0.5		CPMH 	120408-MM				●														12.9	12.7	4.76	0.8	5.5	-	 E213	CPMT 	060204-MM				●														6.4	6.35	2.38	0.4	2.75	-	 E213	080308-MM				●														8.1	7.938	3.40	0.8	3.18	-	09T308-MM				●														9.7	9.525	3.97	0.8	4.4	-	HECN 	090408FN																		9.0	15.875	4.76	0.8	-	-	 E263	090408SN																		9.0	15.875	4.76	0.8	-	-	090408TN																		9.0	15.875	4.76	0.8	-	-		110412FN																		11.0	19.05	4.76	1.2	-	-		110412TN																		11.0	19.05	4.76	1.2	-	-	HPEN 	090408FN																		9.0	15.875	4.76	0.8	-	-	 E263	090408SN																		9.0	15.875	4.76	0.8	-	-	090408EN																		9.0	15.875	4.76	0.8		-	-	110412FN																		11.0	19.05	4.76	1.2		-	-	HPEN-WC 	090408-WC																		9.0	15.875	4.76	0.8	-	-	 E263	110412-WC																		11.0	19.05	4.76	1.2	-	-	LBH 	080																		7.0	8	2.4	4	-	-	 E94	090																		7.5	9	2.4	4.5	-	-	100																		8.5	10		2.6	5	-	-	110																		9.0	11		2.6	5.5	-	-	120																		10.0	12	3	6	-	-	130																		10.5	13	3	6.5	-	-	160																		12.0	16	4	8	-	-	170																		12.5	17	4	8.5	-	-	200																		15.0	20	5	10	-	-	210																		15.5	21	5	10.5	-	-	250																		18.5	25	6	12.5	-	-	260																		19.0	26	6	13	-	-	300																		22.5	30	7	15	-	-	310																		23.0	31	7	15.5	-	-	320																		23.5	32	7	16	-	-	LBS 	080																		7.0	8	2.4	4	-	-	 E94	090																		7.5	9	2.4	4.5	-	-	100																			8.5	10	2.6	5	-	-	110																			9.0	11	2.6	5.5	-	-	120																		10.0	12	3	6	-	-	130																		10.5	13	3	6.5	-	-	160																		12.0	16	4	8	-	-	170																		12.5	17	4	8.5	-	-	200																		15.0	20	5	10	-	-	210																		15.5	21	5	10.5	-	-																																																																
CPMH 	120408-MM				●														12.9	12.7	4.76	0.8	5.5	-	 E213																																																																																																																																																																																																																																																																																																																																																																																																																																																																																																																																																																																																																																																																																																																																																																																																																																																																																																																																																																																																																																																																																						
CPMT 	060204-MM				●														6.4	6.35	2.38	0.4	2.75	-	 E213																																																																																																																																																																																																																																																																																																																																																																																																																																																																																																																																																																																																																																																																																																																																																																																																																																																																																																																																																																																																																																																																																						
	080308-MM				●														8.1	7.938	3.40	0.8	3.18	-																																																																																																																																																																																																																																																																																																																																																																																																																																																																																																																																																																																																																																																																																																																																																																																																																																																																																																																																																																																																																																																																																							
	09T308-MM				●														9.7	9.525	3.97	0.8	4.4	-		HECN 	090408FN																		9.0	15.875	4.76	0.8	-	-	 E263	090408SN																		9.0	15.875	4.76	0.8	-	-	090408TN																		9.0	15.875	4.76	0.8	-	-	110412FN																		11.0	19.05	4.76	1.2	-	-	110412TN																			11.0	19.05	4.76	1.2	-	-	HPEN 	090408FN																			9.0	15.875	4.76	0.8	-	-	 E263	090408SN																		9.0	15.875	4.76	0.8	-	-	090408EN																		9.0	15.875	4.76	0.8	-	-	110412FN																		11.0	19.05	4.76	1.2	-	-	HPEN-WC 	090408-WC																		9.0	15.875	4.76	0.8	-	-	 E263	110412-WC																		11.0	19.05	4.76	1.2	-	-	LBH 	080																		7.0	8	2.4	4	-	-	 E94	090																		7.5	9	2.4	4.5	-	-	100																		8.5	10	2.6	5	-	-	110																		9.0	11	2.6	5.5	-	-	120																			10.0	12	3	6	-	-	130																			10.5	13	3	6.5	-	-	160																		12.0	16	4	8	-	-		170																		12.5	17	4	8.5	-	-		200																		15.0	20	5	10	-	-	210																		15.5	21	5	10.5	-	-	250																		18.5	25	6	12.5	-	-	260																		19.0	26	6	13	-	-	300																		22.5	30	7	15	-	-	310																		23.0	31	7	15.5	-	-	320																		23.5	32	7	16	-	-	LBS 	080																		7.0	8	2.4	4	-	-	 E94	090																		7.5	9	2.4	4.5	-	-	100																		8.5	10	2.6	5	-	-	110																		9.0	11	2.6	5.5	-	-	120																			10.0	12	3	6	-	-	130																			10.5	13	3	6.5	-	-	160																		12.0	16		4	8	-	-	170																		12.5	17		4	8.5	-	-	200																		15.0	20	5	10	-	-	210																		15.5	21	5	10.5	-	-																																																																																																																																																																		
HECN 	090408FN																		9.0	15.875	4.76	0.8	-	-	 E263																																																																																																																																																																																																																																																																																																																																																																																																																																																																																																																																																																																																																																																																																																																																																																																																																																																																																																																																																																																																																																																																																						
	090408SN																		9.0	15.875	4.76	0.8	-	-																																																																																																																																																																																																																																																																																																																																																																																																																																																																																																																																																																																																																																																																																																																																																																																																																																																																																																																																																																																																																																																																																							
	090408TN																		9.0	15.875	4.76	0.8	-	-																																																																																																																																																																																																																																																																																																																																																																																																																																																																																																																																																																																																																																																																																																																																																																																																																																																																																																																																																																																																																																																																																							
	110412FN																		11.0	19.05	4.76	1.2	-	-																																																																																																																																																																																																																																																																																																																																																																																																																																																																																																																																																																																																																																																																																																																																																																																																																																																																																																																																																																																																																																																																																							
	110412TN																		11.0	19.05	4.76	1.2	-	-		HPEN 	090408FN																		9.0	15.875	4.76	0.8	-	-	 E263	090408SN																		9.0	15.875	4.76	0.8	-	-	090408EN																		9.0	15.875	4.76	0.8	-	-	110412FN																		11.0	19.05	4.76	1.2	-	-	HPEN-WC 	090408-WC																		9.0	15.875	4.76	0.8	-	-	 E263	110412-WC																		11.0	19.05	4.76	1.2	-	-	LBH 	080																		7.0	8	2.4	4	-	-	 E94	090																		7.5	9	2.4	4.5	-	-	100																		8.5	10	2.6	5	-	-	110																		9.0	11	2.6	5.5	-	-	120																		10.0	12	3	6	-	-	130																			10.5	13	3	6.5	-	-	160																			12.0	16	4	8	-	-	170																		12.5	17	4	8.5	-	-	200																		15.0	20	5	10	-	-	210																			15.5	21	5	10.5	-	-	250																			18.5	25	6	12.5	-	-	260																		19.0	26	6	13	-	-	300																			22.5	30	7	15	-	-	310																			23.0	31	7	15.5	-	-	320																		23.5	32	7	16	-	-	LBS 	080																		7.0	8	2.4	4	-	-	 E94	090																		7.5	9	2.4	4.5	-	-	100																		8.5	10	2.6	5	-	-	110																		9.0	11	2.6	5.5	-	-	120																		10.0	12	3	6	-	-		130																		10.5	13	3	6.5	-	-		160																		12.0	16	4	8	-	-	170																		12.5	17	4	8.5	-	-	200																		15.0	20	5	10	-	-	210																			15.5	21	5	10.5	-	-																																																																																																																																																																																																																																																																																													
HPEN 	090408FN																		9.0	15.875	4.76	0.8	-	-	 E263																																																																																																																																																																																																																																																																																																																																																																																																																																																																																																																																																																																																																																																																																																																																																																																																																																																																																																																																																																																																																																																																																						
	090408SN																		9.0	15.875	4.76	0.8	-	-																																																																																																																																																																																																																																																																																																																																																																																																																																																																																																																																																																																																																																																																																																																																																																																																																																																																																																																																																																																																																																																																																							
	090408EN																		9.0	15.875	4.76	0.8	-	-																																																																																																																																																																																																																																																																																																																																																																																																																																																																																																																																																																																																																																																																																																																																																																																																																																																																																																																																																																																																																																																																																							
	110412FN																		11.0	19.05	4.76	1.2	-	-		HPEN-WC 	090408-WC																		9.0	15.875	4.76	0.8	-	-	 E263	110412-WC																		11.0	19.05	4.76	1.2	-	-	LBH 	080																		7.0	8	2.4	4	-	-	 E94	090																		7.5	9	2.4	4.5	-	-	100																		8.5	10	2.6	5	-	-	110																		9.0	11	2.6	5.5	-	-		120																		10.0	12	3	6	-	-		130																		10.5	13	3	6.5	-	-	160																		12.0	16	4	8	-	-	170																		12.5	17	4	8.5	-	-	200																		15.0	20	5	10	-	-	210																			15.5	21	5	10.5	-	-	250																			18.5	25	6	12.5	-	-	260																		19.0	26	6	13	-	-	300																		22.5	30	7	15	-	-	310																		23.0	31	7	15.5	-	-	320																		23.5	32	7	16	-	-	LBS 	080																		7.0	8	2.4	4	-	-	 E94	090																		7.5	9	2.4	4.5	-	-	100																		8.5	10	2.6	5	-	-	110																		9.0	11	2.6	5.5	-	-	120																			10.0	12	3	6	-	-	130																			10.5	13	3	6.5	-	-	160																		12.0	16	4	8	-	-	170																		12.5	17	4	8.5	-	-	200																		15.0	20	5	10	-	-	210																			15.5	21	5	10.5	-	-																																																																																																																																																																																																																																																																																																																																																																																																	
HPEN-WC 	090408-WC																		9.0	15.875	4.76	0.8	-	-	 E263																																																																																																																																																																																																																																																																																																																																																																																																																																																																																																																																																																																																																																																																																																																																																																																																																																																																																																																																																																																																																																																																																						
	110412-WC																		11.0	19.05	4.76	1.2	-	-		LBH 	080																		7.0	8	2.4	4	-	-	 E94	090																		7.5	9	2.4	4.5	-	-		100																		8.5	10	2.6	5	-	-		110																		9.0	11	2.6	5.5	-	-	120																		10.0	12	3	6	-	-	130																		10.5	13	3	6.5	-	-		160																		12.0	16	4	8	-	-		170																		12.5	17	4	8.5	-	-	200																		15.0	20	5	10	-	-	210																		15.5	21	5	10.5	-	-	250																		18.5	25	6	12.5	-	-	260																			19.0	26	6	13	-	-	300																			22.5	30	7	15	-	-	310																		23.0	31	7	15.5	-	-	320																		23.5	32	7	16	-	-	LBS 	080																		7.0	8	2.4	4	-	-	 E94	090																		7.5	9	2.4	4.5		-	-	100																		8.5	10	2.6	5		-	-	110																		9.0	11	2.6	5.5	-	-	120																		10.0	12	3	6	-	-	130																		10.5	13	3	6.5	-	-		160																		12.0	16	4	8	-	-		170																		12.5	17	4	8.5	-	-	200																		15.0	20	5	10	-	-	210																		15.5	21	5	10.5	-	-																																																																																																																																																																																																																																																																																																																																																																																																																																																
LBH 	080																		7.0	8	2.4	4	-	-	 E94																																																																																																																																																																																																																																																																																																																																																																																																																																																																																																																																																																																																																																																																																																																																																																																																																																																																																																																																																																																																																																																																																						
	090																		7.5	9	2.4	4.5	-	-																																																																																																																																																																																																																																																																																																																																																																																																																																																																																																																																																																																																																																																																																																																																																																																																																																																																																																																																																																																																																																																																																							
	100																		8.5	10	2.6	5	-	-																																																																																																																																																																																																																																																																																																																																																																																																																																																																																																																																																																																																																																																																																																																																																																																																																																																																																																																																																																																																																																																																																							
	110																		9.0	11	2.6	5.5	-	-																																																																																																																																																																																																																																																																																																																																																																																																																																																																																																																																																																																																																																																																																																																																																																																																																																																																																																																																																																																																																																																																																							
	120																		10.0	12	3	6	-	-																																																																																																																																																																																																																																																																																																																																																																																																																																																																																																																																																																																																																																																																																																																																																																																																																																																																																																																																																																																																																																																																																							
	130																		10.5	13	3	6.5	-	-																																																																																																																																																																																																																																																																																																																																																																																																																																																																																																																																																																																																																																																																																																																																																																																																																																																																																																																																																																																																																																																																																							
	160																		12.0	16	4	8	-	-																																																																																																																																																																																																																																																																																																																																																																																																																																																																																																																																																																																																																																																																																																																																																																																																																																																																																																																																																																																																																																																																																							
	170																		12.5	17	4	8.5	-	-																																																																																																																																																																																																																																																																																																																																																																																																																																																																																																																																																																																																																																																																																																																																																																																																																																																																																																																																																																																																																																																																																							
	200																		15.0	20	5	10	-	-																																																																																																																																																																																																																																																																																																																																																																																																																																																																																																																																																																																																																																																																																																																																																																																																																																																																																																																																																																																																																																																																																							
	210																		15.5	21	5	10.5	-	-																																																																																																																																																																																																																																																																																																																																																																																																																																																																																																																																																																																																																																																																																																																																																																																																																																																																																																																																																																																																																																																																																							
	250																		18.5	25	6	12.5	-	-																																																																																																																																																																																																																																																																																																																																																																																																																																																																																																																																																																																																																																																																																																																																																																																																																																																																																																																																																																																																																																																																																							
	260																		19.0	26	6	13	-	-																																																																																																																																																																																																																																																																																																																																																																																																																																																																																																																																																																																																																																																																																																																																																																																																																																																																																																																																																																																																																																																																																							
	300																		22.5	30	7	15	-	-																																																																																																																																																																																																																																																																																																																																																																																																																																																																																																																																																																																																																																																																																																																																																																																																																																																																																																																																																																																																																																																																																							
310																		23.0	31	7	15.5	-	-																																																																																																																																																																																																																																																																																																																																																																																																																																																																																																																																																																																																																																																																																																																																																																																																																																																																																																																																																																																																																																																																																								
320																		23.5	32	7	16	-	-	LBS 	080																		7.0	8	2.4	4	-	-	 E94	090																		7.5	9	2.4	4.5	-	-	100																		8.5	10	2.6	5	-	-	110																		9.0	11	2.6	5.5	-	-	120																		10.0	12	3	6	-	-	130																		10.5	13	3	6.5	-	-	160																		12.0	16	4	8	-	-	170																		12.5	17	4	8.5	-	-	200																		15.0	20	5	10	-	-	210																		15.5	21	5	10.5	-	-																																																																																																																																																																																																																																																																																																																																																																																																																																																																																																																																																																																																																																																																																																																																																																																																																																						
LBS 	080																		7.0	8	2.4	4	-		-	 E94																																																																																																																																																																																																																																																																																																																																																																																																																																																																																																																																																																																																																																																																																																																																																																																																																																																																																																																																																																																																																																																																																					
	090																		7.5	9	2.4	4.5	-		-																																																																																																																																																																																																																																																																																																																																																																																																																																																																																																																																																																																																																																																																																																																																																																																																																																																																																																																																																																																																																																																																																						
	100																		8.5	10	2.6	5	-		-																																																																																																																																																																																																																																																																																																																																																																																																																																																																																																																																																																																																																																																																																																																																																																																																																																																																																																																																																																																																																																																																																						
	110																		9.0	11	2.6	5.5	-		-																																																																																																																																																																																																																																																																																																																																																																																																																																																																																																																																																																																																																																																																																																																																																																																																																																																																																																																																																																																																																																																																																						
	120																		10.0	12	3	6	-		-																																																																																																																																																																																																																																																																																																																																																																																																																																																																																																																																																																																																																																																																																																																																																																																																																																																																																																																																																																																																																																																																																						
	130																		10.5	13	3	6.5	-		-																																																																																																																																																																																																																																																																																																																																																																																																																																																																																																																																																																																																																																																																																																																																																																																																																																																																																																																																																																																																																																																																																						
	160																		12.0	16	4	8	-		-																																																																																																																																																																																																																																																																																																																																																																																																																																																																																																																																																																																																																																																																																																																																																																																																																																																																																																																																																																																																																																																																																						
	170																		12.5	17	4	8.5	-		-																																																																																																																																																																																																																																																																																																																																																																																																																																																																																																																																																																																																																																																																																																																																																																																																																																																																																																																																																																																																																																																																																						
	200																		15.0	20	5	10	-		-																																																																																																																																																																																																																																																																																																																																																																																																																																																																																																																																																																																																																																																																																																																																																																																																																																																																																																																																																																																																																																																																																						
	210																		15.5	21	5	10.5	-	-																																																																																																																																																																																																																																																																																																																																																																																																																																																																																																																																																																																																																																																																																																																																																																																																																																																																																																																																																																																																																																																																																							

●: Наличие на складе

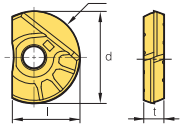
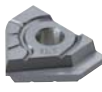
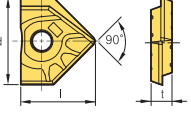
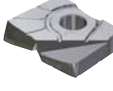
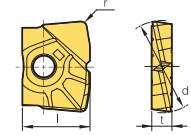
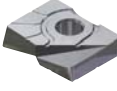
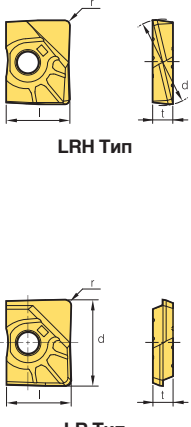

СМП	Обозначение	Обрабатываемые материалы											Размеры СМП (мм)					Геометрия	применяемые корпуса фрез, стр.				
		NCM825	NCM335	NC5330	PC3500	PC5300	PC3545	PC9530	PC6510	PD210F	CN2000	CN20	CN30	H01	G10	ST30A	ST20			l	d	t	r
 LBS	250	●	●	●	●	●	●	●	●	●	●	●	●	●	●	●	18.5	25	6	12.5	-		E94
	260	●	●	●	●	●	●	●	●	●	●	●	●	●	●	●	19.0	26	6	13	-		
	300	●	●	●	●	●	●	●	●	●	●	●	●	●	●	●	22.5	30	7	15	-		
	310	●	●	●	●	●	●	●	●	●	●	●	●	●	●	●	23.0	31	7	15.5	-		
	320	●	●	●	●	●	●	●	●	●	●	●	●	●	●	●	23.5	32	7	16	-		
 LCF	160-D90	●	●	●	●	●	●	●	●	●	●	●	●	●	●	13.7	16	4	-	-		E94	
	200-D90	●	●	●	●	●	●	●	●	●	●	●	●	●	●	17.0	20	5	-	-			
	250-D90	●	●	●	●	●	●	●	●	●	●	●	●	●	●	21.5	25	6	-	-			
 LFH	100	●	●	●	●	●	●	●	●	●	●	●	●	●	●	8.5	10	2.6	1.0	-		E94	
	120	●	●	●	●	●	●	●	●	●	●	●	●	●	●	10.0	12	3	1.0	-			
	160	●	●	●	●	●	●	●	●	●	●	●	●	●	●	12.0	16	4	1.5	-			
	200	●	●	●	●	●	●	●	●	●	●	●	●	●	●	15.0	20	5	1.5	-			
	250	●	●	●	●	●	●	●	●	●	●	●	●	●	●	18.5	25	6	2.0	-			
	300	●	●	●	●	●	●	●	●	●	●	●	●	●	●	22.5	30	7	2.0	-			
	320	●	●	●	●	●	●	●	●	●	●	●	●	●	●	23.5	32	7	2.0	-			
 LRH	100-R05	●	●	●	●	●	●	●	●	●	●	●	●	●	●	8.5	10	2.6	0.5	-	 LRH Тип LR Тип	E94	
	100-R10	●	●	●	●	●	●	●	●	●	●	●	●	●	●	8.5	10	2.6	1.0	-			
	100-R20	●	●	●	●	●	●	●	●	●	●	●	●	●	●	8.5	10	2.6	2.0	-			
	110-R05	●	●	●	●	●	●	●	●	●	●	●	●	●	●	9.0	11	2.6	0.5	-			
	120-R05	●	●	●	●	●	●	●	●	●	●	●	●	●	●	10.0	12	3	0.5	-			
	120-R10	●	●	●	●	●	●	●	●	●	●	●	●	●	●	10.0	12	3	1.0	-			
	120-R20	●	●	●	●	●	●	●	●	●	●	●	●	●	●	10.0	12	3	2.0	-			
	130-R05	●	●	●	●	●	●	●	●	●	●	●	●	●	●	10.5	13	3	0.5	-			
	160-R05	●	●	●	●	●	●	●	●	●	●	●	●	●	●	12.0	16	4	0.5	-			
	160-R10	●	●	●	●	●	●	●	●	●	●	●	●	●	●	12.0	16	4	1.0	-			
	160-R20	●	●	●	●	●	●	●	●	●	●	●	●	●	●	12.0	16	4	2.0	-			
	160-R30	●	●	●	●	●	●	●	●	●	●	●	●	●	●	12.0	16	4	3.0	-			
	170-R05	●	●	●	●	●	●	●	●	●	●	●	●	●	●	12.5	17	4	0.5	-			
	200-R05	●	●	●	●	●	●	●	●	●	●	●	●	●	●	15.0	20	5	0.5	-			
	200-R10	●	●	●	●	●	●	●	●	●	●	●	●	●	●	15.0	20	5	1.0	-			
	200-R20	●	●	●	●	●	●	●	●	●	●	●	●	●	●	15.0	20	5	2.0	-			
	200-R30	●	●	●	●	●	●	●	●	●	●	●	●	●	●	15.0	20	5	3.0	-			
	210-R05	●	●	●	●	●	●	●	●	●	●	●	●	●	●	15.5	21	5	0.5	-			
	250-R05	●	●	●	●	●	●	●	●	●	●	●	●	●	●	18.5	25	6	0.5	-			
	250-R10	●	●	●	●	●	●	●	●	●	●	●	●	●	●	18.5	25	6	1.0	-			
250-R20	●	●	●	●	●	●	●	●	●	●	●	●	●	●	18.5	25	6	2.0	-				
250-R30	●	●	●	●	●	●	●	●	●	●	●	●	●	●	18.5	25	6	3.0	-				
260-R05	●	●	●	●	●	●	●	●	●	●	●	●	●	●	19.0	26	6	0.5	-				
300-R10	●	●	●	●	●	●	●	●	●	●	●	●	●	●	22.5	30	7	1.0	-				
300-R20	●	●	●	●	●	●	●	●	●	●	●	●	●	●	22.5	30	7	2.0	-				
300-R30	●	●	●	●	●	●	●	●	●	●	●	●	●	●	22.5	30	7	3.0	-				
310-R05	●	●	●	●	●	●	●	●	●	●	●	●	●	●	23.0	31	7	0.5	-				
320-R10	●	●	●	●	●	●	●	●	●	●	●	●	●	●	23.5	32	7	1.0	-				
320-R20	●	●	●	●	●	●	●	●	●	●	●	●	●	●	23.5	32	7	2.0	-				
320-R30	●	●	●	●	●	●	●	●	●	●	●	●	●	●	23.5	32	7	3.0	-				

Условия резания ● Непрерывное
 ● Универсальное
 ● Прерывистое



Обрабатываемые материалы	Стали	P	M	K	N	S	H												
	Нержавеющие стали	M																	
	Чугуны	K																	
	Цветные металлы	N																	
	Жаропрочные сплавы, титан	S																	
Материалы с повышенной твердостью	H																		

Условия резания







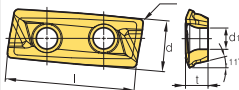

- Непрерывное
- ⊙ Универсальное
- ⊕ Прерывистое

СМП	Обозначение	Твердые сплавы с покрытием										Керметы	Твердые сплавы	Размеры СМП (мм)					Геометрия	применяемые корпуса фрез, стр.					
		NCM325	NCM335	NC5330	PC3500	PC5300	PC5400	PC3545	PC9530	PC6510	PD2000	CN2000	CN20	CN30	H01	G10	ST30A	ST20			l	d	t	r	d1
LNCS	1907-C1.5-WC																		19.05	14.3	7	-	5.8		E268 E269
	1907-R3.0-WC																		19.05	14.3	7	-	5.8		
LNE	324-R0.8																		15.9	9.525	6.35	0.8	4.4		-
	324-C1.0																		15.9	9.525	6.35	1.0	4.4		
LNEX-MF	150608-MF																		15.88	15.23	6.35	0.8	-	-	
	150608-ML																		15.88	15.23	6.35	0.8	-		
LNEX-QNN	1506QNN-MF																		15.88	15.23	6.35	0.8	-		-
	1506QNN-ML																		15.88	15.23	6.35	0.8	-		
LNEX-ANN	1506ANN-MF																		15.88	15.23	6.35	0.8	-	-	
	1506ANN-ML																		15.88	15.23	6.35	0.8	-		

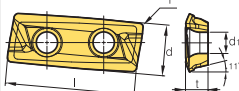
● : Наличие на складе

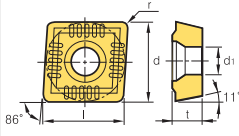
Обрабатываемые материалы	Условия резания													
	●	●	●	●	●	●	●	●	●	●	●	●	●	●
Стали	●	●	●	●	●	●	●	●	●	●	●	●	●	●
Нержавеющие стали	●	●	●	●	●	●	●	●	●	●	●	●	●	●
Чугуны	●	●	●	●	●	●	●	●	●	●	●	●	●	●
Цветные металлы	●	●	●	●	●	●	●	●	●	●	●	●	●	●
Жаропрочные сплавы, титан	●	●	●	●	●	●	●	●	●	●	●	●	●	●
Материалы с повышенной твердостью	●	●	●	●	●	●	●	●	●	●	●	●	●	●

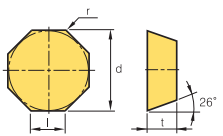

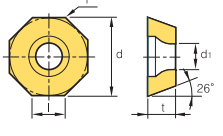







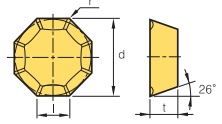

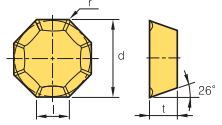

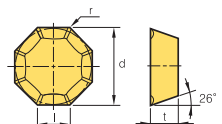

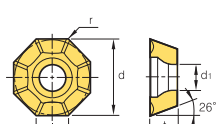

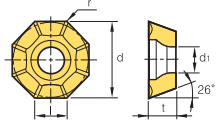

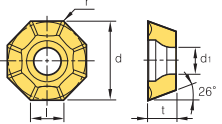

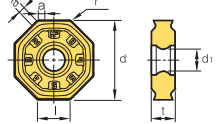

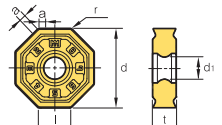

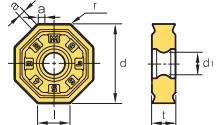

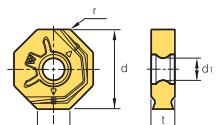

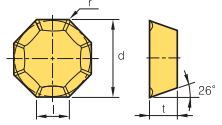

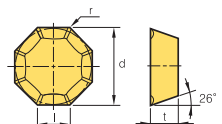

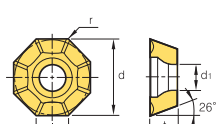

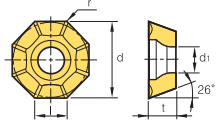

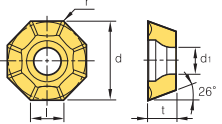

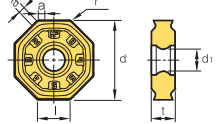

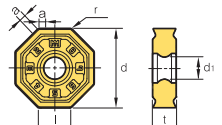

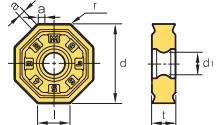

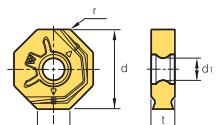

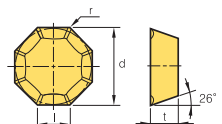

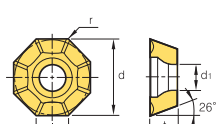

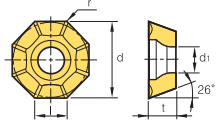

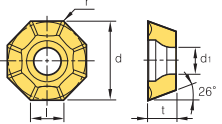

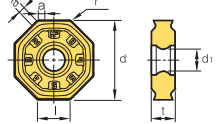

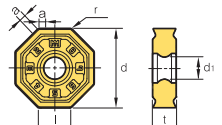

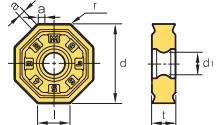

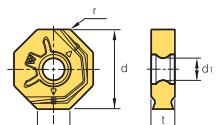

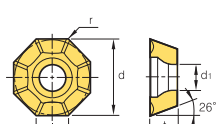

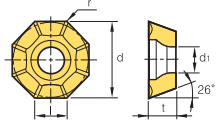

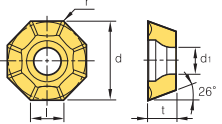

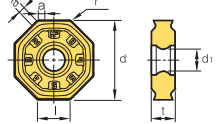

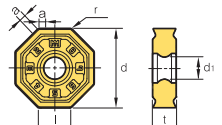

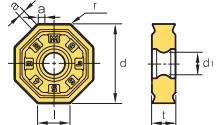

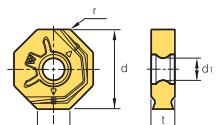

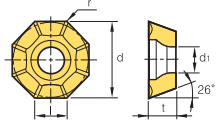

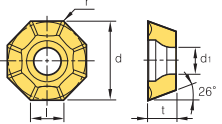

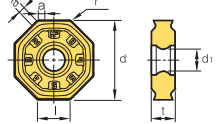

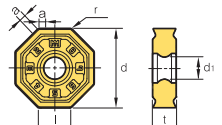

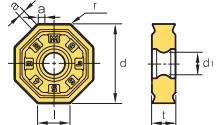

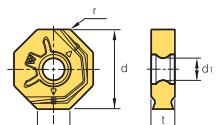

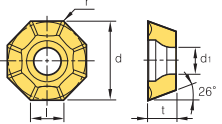

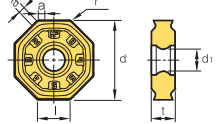

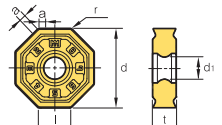

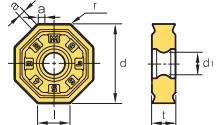

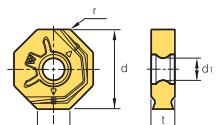

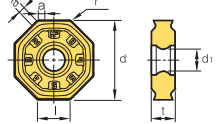

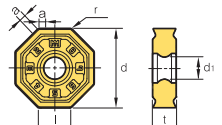

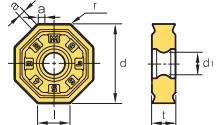

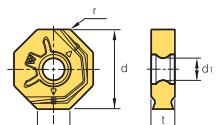

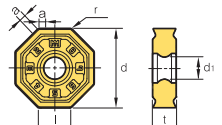
Условия резания ● Непрерывное
 ● Универсальное
 ● Прерывистое

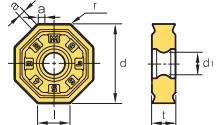
СМП	Обозначение	Твердые сплавы с покрытием										Керметы		Твердые сплавы		Размеры СМП (мм)					Геометрия	применяемые корпуса фрез, стр.	
		NCM325	NCM335	NC5330	PC3500	PC3545	PC9530	PC6510	PC215K	PD2000	CN2000	CN20	CN30	H01	G10	ST30A	ST20	l	d	t			r
	250404PEFR-32-MA																25	10.775	4.76	0.4	4.5		E217~ E219
	2504PEFR-32-MA																25	10.775	4.76	0.8	4.5		
	250412PEFR-32-MA																25	10.775	4.76	1.2	4.5		
	250416PEFR-32-MA																25	10.775	4.76	1.6	4.5		
	250404PEFR-40-MA																25	10.618	4.76	0.4	4.5		
	2504PEFR-40-MA																25	10.618	4.76	0.8	4.5		
	250412PEFR-40-MA																25	10.618	4.76	1.2	4.5		
	250416PEFR-40-MA																25	10.618	4.76	1.6	4.5		
	340504PEFR-50-MA																34	13.765	5.56	0.4	5.56		
	3405PEFR-50-MA																34	13.765	5.56	0.8	5.56		
	340512PEFR-50-MA																34	13.765	5.56	1.2	5.56		
	340516PEFR-50-MA																34	13.765	5.56	1.6	5.56		
	340504PEFR-63-MA																34	13.803	5.56	0.4	5.56		
	3405PEFR-63-MA																34	13.803	5.56	0.8	5.56		
	340512PEFR-63-MA																34	13.803	5.56	1.2	5.56		
	340516PEFR-63-MA																34	13.803	5.56	1.6	5.56		
	250404PEER-32-ML															25	10.775	4.76	0.4	4.5		E217~ E219	
	2504PEER-32-ML															25	10.775	4.76	0.8	4.5			
	250412PEER-32-ML															25	10.775	4.76	1.2	4.5			
	250416PEER-32-ML															25	10.775	4.76	1.6	4.5			
	250404PEER-40-ML																25	10.618	4.76	0.4			4.5
	2504PEER-40-ML																25	10.618	4.76	0.8			4.5
	250412PEER-40-ML																25	10.618	4.76	1.2			4.5
	250416PEER-40-ML																25	10.618	4.76	1.6			4.5
	340504PEER-50-ML																34	13.765	5.56	0.4			5.56
	3405PEER-50-ML																34	13.765	5.56	0.8			5.56
	340512PEER-50-ML																34	13.765	5.56	1.2			5.56
	340516PEER-50-ML																34	13.765	5.56	1.6			5.56
	340504PEER-63-ML																34	13.803	5.56	0.4			5.56
	340508PEER-63-ML																34	13.803	5.56	0.8			5.56
340512PEER-63-ML																34	13.803	5.56	1.2	5.56			
340516PEER-63-ML																34	13.803	5.56	1.6	5.56			
	090308															9.5	9.525	3.18	0.8	4.5		-	
	120408															12.7	12.7	4.76	0.8	5.5			
	0704SN															7.4	18	4.86	0.5	-		E48	
	0704FN															7.4	18	4.86	0.5	-			
	070408SN															7.4	18	4.86	0.8	-			
	070408FN															7.4	18	4.86	0.8	-			
	070408TN															7.4	18	4.86	0.8	-			
	05T3SN															5.2	12.7	3.85	0.5	4.4		E48	
	05T3FN															5.2	12.7	3.85	0.5	4.4			
	05T308FN															5.2	12.7	3.85	0.8	4.4			

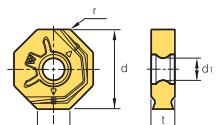
● : Наличие на складе

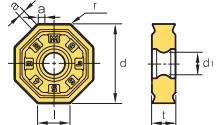
Обрабатываемые материалы	Стали	P	●	●	●	●	●	●	●	●	●	●	●	●	●	●	●	●	●	●
	Нержавеющие стали	M	●	●	●	●	●	●	●	●	●	●	●	●	●	●	●	●	●	●
Чугуны	K	●	●	●	●	●	●	●	●	●	●	●	●	●	●	●	●	●	●	●
Цветные металлы	N	●	●	●	●	●	●	●	●	●	●	●	●	●	●	●	●	●	●	●
Жаропрочные сплавы, титан	S	●	●	●	●	●	●	●	●	●	●	●	●	●	●	●	●	●	●	●
Материалы с повышенной твердостью	H	●	●	●	●	●	●	●	●	●	●	●	●	●	●	●	●	●	●	●

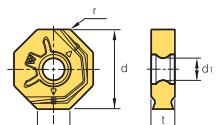

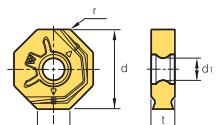







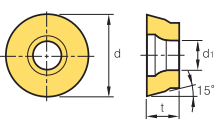

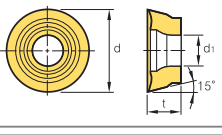
Условия резания ● Непрерывное
● Универсальное
● Прерывистое

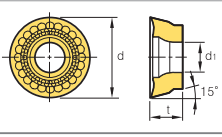
СМП	Обозначение	Твердые сплавы с покрытием		Керметы		Твердые сплавы		Размеры СМП (мм)						Геометрия	применяемые корпуса фрез, стр.																																																																																																																																																																																																																																																																																																																																																																																																																																																																																																																																																																																																							
		NCM325	NCM335	NC5330	PC3500	PC5300	PC3545	PC9530	PC6510	PD2000	CN2000	CN30	CN30			H01	G10	ST30A	ST20	l	d	t	r	d ₁	a																																																																																																																																																																																																																																																																																																																																																																																																																																																																																																																																																																																													
OFKR-MA 	0704FN-MA	●	●	●	●	●	●	●	●	●	●	●	●	●	●	●	7.4	18	4.76	0.5	-	-		E48																																																																																																																																																																																																																																																																																																																																																																																																																																																																																																																																																																																														
	0704EN-MA	●	●	●	●	●	●	●	●	●	●	●	●	●	●	●	7.4	18	4.76	0.5	-	-			OFKR-MF 	0704SN-MF	●	●	●	●	●	●	●	●	●	●	●	●	●	●	●	7.4	18	4.76	0.5	-	-		E48	070408SN-MF	●	●	●	●	●	●	●	●	●	●	●	●	●	●	●	7.4	18	4.76	0.8	-	-	OFKR-MM 	0704SN-MM	●	●	●	●	●	●	●	●	●	●	●	●	●	●	●	7.4	18	4.76	0.5	-	-		E48	070408SN-MM	●	●	●	●	●	●	●	●	●	●	●	●	●	●	●	7.4	18	4.76	0.8	-	-	OFKT-MA 	05T3FN-MA	●	●	●	●	●	●	●	●	●	●	●	●	●	●	●	5.2	12.7	3.97	0.5	4.4	-		E47 E48	05T3EN-MA	●	●	●	●	●	●	●	●	●	●	●	●	●	●	●	5.2	12.7	3.97	0.5	4.4	-	0704FN-MA	●	●	●	●	●	●	●	●	●	●	●	●	●	●	●	7.4	18	4.76	0.5	5.8	-	0704EN-MA	●	●	●	●	●	●	●	●	●	●	●	●	●	●	●	7.4	18	4.76	0.5	5.8	-	OFKT-MF 	05T3SN-MF	●	●	●	●	●	●	●	●	●	●	●	●	●	●	●	5.2	12.7	3.97	0.5	4.4	-		E47	05T308SN-MF	●	●	●	●	●	●	●	●	●	●	●	●	●	●	●	5.2	12.7	3.97	0.8	5.8	-	OFKT-MM 	05T3SN-MM	●	●	●	●	●	●	●	●	●	●	●	●	●	●	●	5.2	12.7	3.97	0.5	4.4	-		E47 E48	05T308SN-MM	●	●	●	●	●	●	●	●	●	●	●	●	●	●	●	5.2	12.7	3.97	0.8	4.4	-	0704SN-MM	●	●	●	●	●	●	●	●	●	●	●	●	●	●	●	7.4	18	4.76	0.5	5.5	-	ONHX-MF 	060608-MF	●	●	●	●	●	●	●	●	●	●	●	●	●	●	●	6.6	16.0	6.0	0.8	5.6	-		E70 E71	080608-MF	●	●	●	●	●	●	●	●	●	●	●	●	●	●	●	8.4	20.2	6.0	0.8	5.6	-	0606ANN-MF	●	●	●	●	●	●	●	●	●	●	●	●	●	●	●	6.6	16.0	6.0	0.8	5.6	1.03	0806ANN-MF	●	●	●	●	●	●	●	●	●	●	●	●	●	●	●	8.4	20.2	6.0	0.8	5.6	1.53	ONHX-MM 	060608-MM	●	●	●	●	●	●	●	●	●	●	●	●	●	●	●	6.6	16.0	6.0	0.8	5.6	-		E70 E71	080608-MM	●	●	●	●	●	●	●	●	●	●	●	●	●	●	●	8.4	20.2	6.0	0.8	5.6	-	0606ANN-MM	●	●	●	●	●	●	●	●	●	●	●	●	●	●	●	6.6	16.0	6.0	0.8	5.6	1.03	0806ANN-MM	●	●	●	●	●	●	●	●	●	●	●	●	●	●	●	8.4	20.2	6.0	0.8	5.6	1.53	ONHX-MA 	060608-MA	●	●	●	●	●	●	●	●	●	●	●	●	●	●	●	6.6	16.0	6.0	0.8	5.6	-		E70 E71	080608-MA	●	●	●	●	●	●	●	●	●	●	●	●	●	●	●	8.4	20.2	6.0	0.8	5.6	-	ONHX-W 	060608-W	●	●	●	●	●	●	●	●	●	●	●	●	●	●	●	6.5	16.0	6.0	0.8	5.6	-		E70 E71	080608-W	●	●	●	●	●	●	●	●	●	●	●	●	●	●	●	8.2	20.2	6.0
OFKR-MF 	0704SN-MF	●	●	●	●	●	●	●	●	●	●	●	●	●	●	●	7.4	18	4.76	0.5	-	-		E48																																																																																																																																																																																																																																																																																																																																																																																																																																																																																																																																																																																														
	070408SN-MF	●	●	●	●	●	●	●	●	●	●	●	●	●	●	●	7.4	18	4.76	0.8	-	-			OFKR-MM 	0704SN-MM	●	●	●	●	●	●	●	●	●	●	●	●	●	●	●	7.4	18	4.76	0.5	-	-		E48	070408SN-MM	●	●	●	●	●	●	●	●	●	●	●	●	●	●	●	7.4	18	4.76	0.8	-	-	OFKT-MA 	05T3FN-MA	●	●	●	●	●	●	●	●	●	●	●	●	●	●	●	5.2	12.7	3.97	0.5	4.4	-		E47 E48	05T3EN-MA	●	●	●	●	●	●	●	●	●	●	●	●	●	●	●	5.2	12.7	3.97	0.5	4.4	-		0704FN-MA	●	●	●	●	●	●	●	●	●	●	●	●	●	●	●	7.4	18	4.76	0.5	5.8	-			0704EN-MA	●	●	●	●	●	●	●	●	●	●	●	●	●	●	●	7.4	18	4.76	0.5	5.8	-	OFKT-MF 	05T3SN-MF	●	●	●	●	●	●	●	●	●	●	●	●	●	●	●	5.2	12.7	3.97	0.5	4.4	-		E47	05T308SN-MF	●	●	●	●	●	●	●	●	●	●	●	●	●	●	●	5.2	12.7	3.97	0.8	5.8	-	OFKT-MM 	05T3SN-MM	●	●	●	●	●	●	●	●	●	●	●	●	●	●	●	5.2	12.7	3.97	0.5	4.4	-		E47 E48	05T308SN-MM	●	●	●	●	●	●	●	●	●	●	●	●	●	●	●	5.2	12.7	3.97		0.8	4.4	-	0704SN-MM	●	●	●	●	●	●	●	●	●	●	●	●	●	●	●	7.4	18	4.76			0.5	5.5	-	ONHX-MF 	060608-MF	●	●	●	●	●	●	●	●	●	●	●	●	●	●	●	6.6	16.0	6.0	0.8	5.6	-		E70 E71	080608-MF	●	●	●	●	●	●	●	●	●	●	●	●	●	●	●		8.4	20.2	6.0	0.8	5.6	-	0606ANN-MF	●	●	●	●	●	●	●	●	●	●	●	●	●	●	●			6.6	16.0	6.0	0.8	5.6	1.03	0806ANN-MF	●	●	●	●	●	●	●	●	●	●	●	●	●	●	●	8.4	20.2	6.0	0.8	5.6	1.53	ONHX-MM 	060608-MM	●	●	●	●	●	●	●	●	●	●	●	●	●	●	●	6.6	16.0	6.0	0.8	5.6	-		E70 E71	080608-MM	●	●	●	●	●	●	●	●	●	●	●	●		●	●	●	8.4	20.2	6.0	0.8	5.6	-	0606ANN-MM	●	●	●	●	●	●	●	●	●	●	●	●			●	●	●	6.6	16.0	6.0	0.8	5.6	1.03	0806ANN-MM	●	●	●	●	●	●	●	●	●	●	●	●	●	●	●	8.4	20.2	6.0	0.8	5.6	1.53	ONHX-MA 	060608-MA	●	●	●	●	●	●	●	●	●	●	●	●	●	●	●	6.6	16.0	6.0	0.8	5.6	-		E70 E71	080608-MA	●	●	●	●	●	●	●	●	●	●	●	●	●	●	●	8.4	20.2	6.0	0.8	5.6	-	ONHX-W 	060608-W	●	●	●	●	●	●	●	●	●	●	●	●	●	●	●	6.5	16.0	6.0	0.8	5.6	-		E70 E71	080608-W	●	●	●	●	●	●	●	●	●	●	●	●	●	●	●	8.2	20.2	6.0	0.8	5.6	-																																
OFKR-MM 	0704SN-MM	●	●	●	●	●	●	●	●	●	●	●	●	●	●	●	7.4	18	4.76	0.5	-	-		E48																																																																																																																																																																																																																																																																																																																																																																																																																																																																																																																																																																																														
	070408SN-MM	●	●	●	●	●	●	●	●	●	●	●	●	●	●	●	7.4	18	4.76	0.8	-	-			OFKT-MA 	05T3FN-MA	●	●	●	●	●	●	●	●	●	●	●	●	●	●	●	5.2	12.7	3.97	0.5	4.4	-		E47 E48	05T3EN-MA	●	●	●	●	●	●	●	●	●	●	●	●	●	●	●	5.2	12.7	3.97	0.5	4.4	-		0704FN-MA	●	●	●	●	●	●	●	●	●	●	●	●	●	●	●	7.4	18	4.76	0.5	5.8	-			0704EN-MA	●	●	●	●	●	●	●	●	●	●	●	●	●	●	●	7.4	18	4.76	0.5	5.8	-	OFKT-MF 	05T3SN-MF	●	●	●	●	●	●	●	●	●	●	●	●	●	●	●	5.2	12.7	3.97	0.5	4.4	-		E47	05T308SN-MF	●	●	●	●	●	●	●	●	●	●	●	●	●	●	●	5.2	12.7	3.97	0.8	5.8	-	OFKT-MM 	05T3SN-MM	●	●	●	●	●	●	●	●	●	●	●	●	●	●	●	5.2	12.7	3.97	0.5	4.4	-		E47 E48	05T308SN-MM	●	●	●	●	●	●	●	●	●	●	●	●	●	●	●	5.2	12.7	3.97	0.8	4.4	-		0704SN-MM	●	●	●	●	●	●	●	●	●	●	●	●	●	●	●	7.4	18	4.76	0.5	5.5	-			ONHX-MF 	060608-MF	●	●	●	●	●	●	●	●	●	●	●	●	●	●	●	6.6	16.0	6.0	0.8	5.6	-		E70 E71	080608-MF	●	●	●	●	●	●	●	●	●	●	●	●	●	●	●	8.4	20.2	6.0	0.8	5.6	-		0606ANN-MF	●	●	●	●	●	●	●	●	●	●	●	●	●	●	●	6.6	16.0	6.0	0.8	5.6	1.03			0806ANN-MF	●	●	●	●	●	●	●	●	●	●	●	●	●	●	●	8.4	20.2	6.0	0.8	5.6	1.53	ONHX-MM 	060608-MM	●	●	●	●	●	●	●	●	●	●	●	●	●	●	●	6.6	16.0	6.0	0.8	5.6	-		E70 E71	080608-MM	●	●	●	●	●	●	●	●	●	●	●	●	●	●	●	8.4	20.2	6.0	0.8	5.6	-		0606ANN-MM	●	●	●	●	●	●	●	●	●	●	●	●	●	●	●	6.6	16.0	6.0	0.8	5.6	1.03			0806ANN-MM	●	●	●	●	●	●	●	●	●	●	●	●	●	●	●	8.4	20.2	6.0	0.8	5.6	1.53	ONHX-MA 	060608-MA	●	●	●	●	●	●	●	●	●	●	●	●	●	●	●	6.6	16.0	6.0	0.8	5.6	-		E70 E71	080608-MA	●	●	●	●	●	●	●	●	●	●	●	●	●	●	●	8.4	20.2	6.0	0.8	5.6	-	ONHX-W 	060608-W	●	●	●	●	●	●	●	●	●	●	●	●	●	●	●	6.5	16.0	6.0	0.8	5.6	-		E70 E71	080608-W	●	●	●	●	●	●	●	●	●	●	●	●	●	●	●	8.2	20.2	6.0	0.8	5.6	-																																																																															
OFKT-MA 	05T3FN-MA	●	●	●	●	●	●	●	●	●	●	●	●	●	●	●	5.2	12.7	3.97	0.5	4.4	-		E47 E48																																																																																																																																																																																																																																																																																																																																																																																																																																																																																																																																																																																														
	05T3EN-MA	●	●	●	●	●	●	●	●	●	●	●	●	●	●	●	5.2	12.7	3.97	0.5	4.4	-																																																																																																																																																																																																																																																																																																																																																																																																																																																																																																																																																																																																
	0704FN-MA	●	●	●	●	●	●	●	●	●	●	●	●	●	●	●	7.4	18	4.76	0.5	5.8	-																																																																																																																																																																																																																																																																																																																																																																																																																																																																																																																																																																																																
	0704EN-MA	●	●	●	●	●	●	●	●	●	●	●	●	●	●	●	7.4	18	4.76	0.5	5.8	-			OFKT-MF 	05T3SN-MF	●	●	●	●	●	●	●	●	●	●	●	●	●	●	●	5.2	12.7	3.97	0.5	4.4	-		E47	05T308SN-MF	●	●	●	●	●	●	●	●	●	●	●	●	●	●	●	5.2	12.7	3.97	0.8	5.8	-	OFKT-MM 	05T3SN-MM	●	●	●	●	●	●	●	●	●	●	●	●	●	●	●	5.2	12.7	3.97	0.5	4.4	-		E47 E48	05T308SN-MM	●	●	●	●	●	●	●	●	●	●	●	●	●	●	●	5.2	12.7	3.97	0.8	4.4	-	0704SN-MM	●	●	●	●	●	●	●	●	●	●	●	●	●	●	●	7.4	18	4.76	0.5	5.5	-	ONHX-MF 	060608-MF	●	●	●	●	●	●	●	●	●	●	●	●	●	●	●	6.6	16.0	6.0	0.8	5.6	-		E70 E71	080608-MF	●	●	●	●	●	●	●	●	●	●	●	●	●	●	●	8.4	20.2	6.0	0.8	5.6	-	0606ANN-MF	●	●	●	●	●	●	●	●	●	●	●	●	●	●	●	6.6	16.0	6.0	0.8	5.6	1.03	0806ANN-MF	●	●	●	●	●	●	●	●	●	●	●	●	●	●	●	8.4	20.2	6.0	0.8	5.6	1.53	ONHX-MM 	060608-MM	●	●	●	●	●	●	●	●	●	●	●	●	●	●	●	6.6	16.0	6.0	0.8	5.6	-		E70 E71	080608-MM	●	●	●	●	●	●	●	●	●	●	●	●	●	●	●	8.4	20.2	6.0	0.8	5.6	-	0606ANN-MM	●	●	●	●	●	●	●	●	●	●	●	●	●	●	●	6.6	16.0	6.0	0.8	5.6	1.03	0806ANN-MM	●	●	●	●	●	●	●	●	●	●	●	●	●	●	●	8.4	20.2	6.0	0.8	5.6	1.53	ONHX-MA 	060608-MA	●	●	●	●	●	●	●	●	●	●	●	●	●	●	●	6.6	16.0	6.0	0.8	5.6	-		E70 E71	080608-MA	●	●	●	●	●	●	●	●	●	●	●	●	●	●	●	8.4	20.2	6.0	0.8	5.6	-	ONHX-W 	060608-W	●	●	●	●	●	●	●	●	●	●	●	●	●	●	●	6.5	16.0	6.0	0.8	5.6	-		E70 E71	080608-W	●	●	●	●	●	●	●	●	●	●	●	●	●	●	●	8.2	20.2	6.0	0.8	5.6	-																																																																																																																																																																																						
OFKT-MF 	05T3SN-MF	●	●	●	●	●	●	●	●	●	●	●	●	●	●	●	5.2	12.7	3.97	0.5	4.4	-		E47																																																																																																																																																																																																																																																																																																																																																																																																																																																																																																																																																																																														
	05T308SN-MF	●	●	●	●	●	●	●	●	●	●	●	●	●	●	●	5.2	12.7	3.97	0.8	5.8	-			OFKT-MM 	05T3SN-MM	●	●	●	●	●	●	●	●	●	●	●	●	●	●	●	5.2	12.7	3.97	0.5	4.4	-		E47 E48	05T308SN-MM	●	●	●	●	●	●	●	●	●	●	●	●	●	●	●	5.2	12.7	3.97	0.8	4.4	-		0704SN-MM	●	●	●	●	●	●	●	●	●	●	●	●	●	●	●	7.4	18	4.76	0.5	5.5	-			ONHX-MF 	060608-MF	●	●	●	●	●	●	●	●	●	●	●	●	●	●	●	6.6	16.0	6.0	0.8	5.6	-		E70 E71	080608-MF	●	●	●	●	●	●	●	●	●	●	●	●	●	●	●	8.4	20.2	6.0		0.8	5.6	-	0606ANN-MF	●	●	●	●	●	●	●	●	●	●	●	●	●	●	●	6.6	16.0	6.0			0.8	5.6	1.03	0806ANN-MF	●	●	●	●	●	●	●	●	●	●	●	●	●	●	●	8.4	20.2	6.0	0.8	5.6	1.53	ONHX-MM 	060608-MM	●	●	●	●	●	●	●	●	●	●	●	●	●	●	●	6.6	16.0	6.0	0.8	5.6	-		E70 E71	080608-MM	●	●	●	●	●	●	●	●	●	●	●	●	●	●	●		8.4	20.2	6.0	0.8	5.6	-	0606ANN-MM	●	●	●	●	●	●	●	●	●	●	●	●	●	●	●			6.6	16.0	6.0	0.8	5.6	1.03	0806ANN-MM	●	●	●	●	●	●	●	●	●	●	●	●	●	●	●	8.4	20.2	6.0	0.8	5.6	1.53	ONHX-MA 	060608-MA	●	●	●	●	●	●	●	●	●	●	●	●	●	●	●	6.6	16.0	6.0	0.8	5.6	-		E70 E71	080608-MA	●	●	●	●	●	●	●	●	●	●	●	●	●	●	●	8.4	20.2	6.0	0.8	5.6	-	ONHX-W 	060608-W	●	●	●	●	●	●	●	●	●	●	●	●	●	●	●	6.5	16.0	6.0	0.8	5.6	-		E70 E71	080608-W	●	●	●	●	●	●	●	●	●	●	●	●	●	●	●	8.2	20.2	6.0	0.8	5.6	-																																																																																																																																																																																																																												
OFKT-MM 	05T3SN-MM	●	●	●	●	●	●	●	●	●	●	●	●	●	●	●	5.2	12.7	3.97	0.5	4.4	-		E47 E48																																																																																																																																																																																																																																																																																																																																																																																																																																																																																																																																																																																														
	05T308SN-MM	●	●	●	●	●	●	●	●	●	●	●	●	●	●	●	5.2	12.7	3.97	0.8	4.4	-																																																																																																																																																																																																																																																																																																																																																																																																																																																																																																																																																																																																
	0704SN-MM	●	●	●	●	●	●	●	●	●	●	●	●	●	●	●	7.4	18	4.76	0.5	5.5	-			ONHX-MF 	060608-MF	●	●	●	●	●	●	●	●	●	●	●	●	●	●	●	6.6	16.0	6.0	0.8	5.6	-		E70 E71	080608-MF	●	●	●	●	●	●	●	●	●	●	●	●	●	●	●	8.4	20.2	6.0	0.8	5.6	-	0606ANN-MF	●	●	●	●	●	●	●	●	●	●	●	●	●	●	●	6.6	16.0	6.0	0.8	5.6	1.03	0806ANN-MF	●	●		●	●	●	●	●	●	●	●	●	●	●	●	●	8.4	20.2	6.0	0.8	5.6	1.53	ONHX-MM 	060608-MM	●			●	●	●	●	●	●	●	●	●	●	●	●	●	●	6.6	16.0	6.0	0.8	5.6	-		E70 E71	080608-MM	●	●	●	●	●	●	●	●	●	●	●	●	●	●	●	8.4	20.2	6.0	0.8	5.6	-	0606ANN-MM	●	●	●	●	●	●	●	●	●	●	●	●	●	●	●	6.6	16.0	6.0	0.8	5.6	1.03	0806ANN-MM	●	●		●	●	●	●	●	●	●	●	●	●	●	●	●	8.4	20.2	6.0	0.8	5.6	1.53	ONHX-MA 	060608-MA	●			●	●	●	●	●	●	●	●	●	●	●	●	●	●	6.6	16.0	6.0	0.8	5.6	-		E70 E71	080608-MA	●	●	●	●	●	●	●	●	●	●	●	●	●	●	●	8.4	20.2	6.0	0.8	5.6	-	ONHX-W 	060608-W	●	●	●	●	●	●	●	●	●	●	●	●	●	●	●	6.5	16.0	6.0	0.8	5.6	-		E70 E71	080608-W	●	●	●	●	●	●	●	●	●	●	●	●	●	●	●	8.2	20.2	6.0	0.8	5.6	-																																																																																																																																																																																																																																																																																																				
ONHX-MF 	060608-MF	●	●	●	●	●	●	●	●	●	●	●	●	●	●	●	6.6	16.0	6.0	0.8	5.6	-		E70 E71																																																																																																																																																																																																																																																																																																																																																																																																																																																																																																																																																																																														
	080608-MF	●	●	●	●	●	●	●	●	●	●	●	●	●	●	●	8.4	20.2	6.0	0.8	5.6	-																																																																																																																																																																																																																																																																																																																																																																																																																																																																																																																																																																																																
	0606ANN-MF	●	●	●	●	●	●	●	●	●	●	●	●	●	●	●	6.6	16.0	6.0	0.8	5.6	1.03																																																																																																																																																																																																																																																																																																																																																																																																																																																																																																																																																																																																
	0806ANN-MF	●	●	●	●	●	●	●	●	●	●	●	●	●	●	●	8.4	20.2	6.0	0.8	5.6	1.53			ONHX-MM 	060608-MM	●	●	●	●	●	●	●	●	●	●	●	●	●	●	●	6.6	16.0	6.0	0.8	5.6	-		E70 E71	080608-MM	●	●	●	●	●	●	●	●	●	●	●	●	●	●	●	8.4	20.2	6.0	0.8	5.6	-	0606ANN-MM	●	●	●	●	●	●	●	●	●	●	●	●	●	●	●	6.6	16.0	6.0	0.8	5.6	1.03	0806ANN-MM	●	●	●	●	●	●	●	●	●	●	●	●	●	●	●	8.4	20.2	6.0	0.8	5.6	1.53	ONHX-MA 	060608-MA	●	●	●	●	●	●	●	●	●	●	●	●	●	●	●	6.6	16.0	6.0	0.8	5.6	-		E70 E71	080608-MA	●	●	●	●	●	●	●	●	●	●	●	●	●	●	●	8.4	20.2	6.0	0.8	5.6	-	ONHX-W 	060608-W	●	●	●	●	●	●	●	●	●	●	●	●	●	●	●	6.5	16.0	6.0	0.8	5.6	-		E70 E71	080608-W	●	●	●	●	●	●	●	●	●	●	●	●	●	●	●	8.2	20.2	6.0	0.8	5.6	-																																																																																																																																																																																																																																																																																																																																																																																																					
ONHX-MM 	060608-MM	●	●	●	●	●	●	●	●	●	●	●	●	●	●	●	6.6	16.0	6.0	0.8	5.6	-		E70 E71																																																																																																																																																																																																																																																																																																																																																																																																																																																																																																																																																																																														
	080608-MM	●	●	●	●	●	●	●	●	●	●	●	●	●	●	●	8.4	20.2	6.0	0.8	5.6	-																																																																																																																																																																																																																																																																																																																																																																																																																																																																																																																																																																																																
	0606ANN-MM	●	●	●	●	●	●	●	●	●	●	●	●	●	●	●	6.6	16.0	6.0	0.8	5.6	1.03																																																																																																																																																																																																																																																																																																																																																																																																																																																																																																																																																																																																
	0806ANN-MM	●	●	●	●	●	●	●	●	●	●	●	●	●	●	●	8.4	20.2	6.0	0.8	5.6	1.53			ONHX-MA 	060608-MA	●	●	●	●	●	●	●	●	●	●	●	●	●	●	●	6.6	16.0	6.0	0.8	5.6	-		E70 E71	080608-MA	●	●	●	●	●	●	●	●	●	●	●	●	●	●	●	8.4	20.2	6.0	0.8	5.6	-	ONHX-W 	060608-W	●	●	●	●	●	●	●	●	●	●	●	●	●	●	●	6.5	16.0	6.0	0.8	5.6	-		E70 E71	080608-W	●	●	●	●	●	●	●	●	●	●	●	●	●	●	●	8.2	20.2	6.0	0.8	5.6	-																																																																																																																																																																																																																																																																																																																																																																																																																																																																																																
ONHX-MA 	060608-MA	●	●	●	●	●	●	●	●	●	●	●	●	●	●	●	6.6	16.0	6.0	0.8	5.6	-		E70 E71																																																																																																																																																																																																																																																																																																																																																																																																																																																																																																																																																																																														
	080608-MA	●	●	●	●	●	●	●	●	●	●	●	●	●	●	●	8.4	20.2	6.0	0.8	5.6	-			ONHX-W 	060608-W	●	●	●	●	●	●	●	●	●	●	●	●	●	●	●	6.5	16.0	6.0	0.8	5.6	-		E70 E71	080608-W	●	●	●	●	●	●	●	●	●	●	●	●	●	●	●	8.2	20.2	6.0	0.8	5.6	-																																																																																																																																																																																																																																																																																																																																																																																																																																																																																																																																															
ONHX-W 	060608-W	●	●	●	●	●	●	●	●	●	●	●	●	●	●	●	6.5	16.0	6.0	0.8	5.6	-		E70 E71																																																																																																																																																																																																																																																																																																																																																																																																																																																																																																																																																																																														
	080608-W	●	●	●	●	●	●	●	●	●	●	●	●	●	●	●	8.2	20.2	6.0	0.8	5.6	-																																																																																																																																																																																																																																																																																																																																																																																																																																																																																																																																																																																																

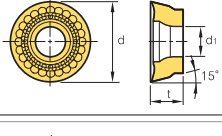
● : Наличие на складе

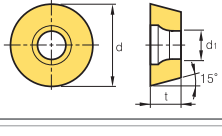

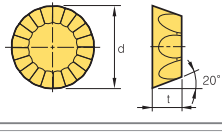
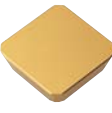
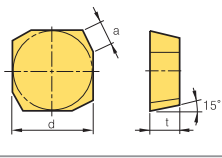
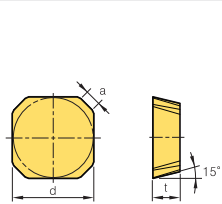

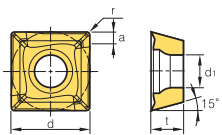



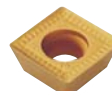
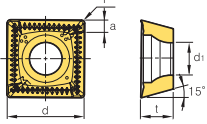

Обработываемые материалы	Условия резания																		Геометрия	применяемые корпуса фрез, стр.									
	Стали	Нержавеющие стали	Чугуны	Цветные металлы	Жаропрочные сплавы, титан	Материалы с повышенной твердостью	●	●	●	●	●	●	●	●	●	●	●	●			●								
СМП	Обозначение	Твердые сплавы с покрытием				Керметы			Твердые сплавы				Размеры СМП (мм)																
		NCM325	NCM335	NC5330	PC3500	PC5300	PC5400	PC3545	PC9530	PC6510	PC210F	CN2000	CN20	CN30	H01	G10	ST30A	ST20	l	d	t	r	d ₁	a	Диаметр фрезы	W	g		
	060608-MF			●														6.6	16.0	6.0	0.8	5.6	-	-	-	-		E70	
	080608-MF																	8.4	20.2	6.0	0.8	5.6	-	-	-	-		E71	
	0606ANN-MF				●	●			●									6.6	16.0	6.0	0.8	5.6	1.03	-	-	-			
	0806ANN-MF				●	●			●									8.4	20.2	6.0	0.8	5.6	1.53	-	-	-			
	060608-MM			●														6.6	16.0	6.0	0.8	5.6	-	-	-	-		E70	
	080608-MM				●	●			●									8.4	20.2	6.0	0.8	5.6	-	-	-	-		E71	
	0606ANN-MM				●	●			●									6.6	16.0	6.0	0.8	5.6	1.03	-	-	-			
	0806ANN-MM				●	●			●									8.4	20.2	6.0	0.8	5.6	1.53	-	-	-			
	265				●													10	7	3.0	0.3	3.5	-	-	2.65	2.8		E204	
	325				●													10	7	3.0	0.3	3.5	-	-	3.25	2.8			
	405				●													15	12	4.5	0.5	4.5	-	-	4.05	4.5			
	470				●													15	12	4.5	0.5	4.5	-	-	4.70	4.5			
	1223N				●													-	12.7	2.3	-	5.0	-	4.0	-	-		E243	
	1225N																	-	12.7	2.5	-	5.0	-	4.5	-	-		E244	
	1230N																	-	12.7	3.0	-	5.0	-	5.0	-	-			
	1235N				●													-	12.7	3.5	-	5.0	-	6.0	-	-			
	1240N				●													-	12.7	4.0	-	5.0	-	7.0	-	-			
	1245N	●			●													-	12.7	4.5	-	5.0	-	8.0	-	-			
	1250N																	-	12.7	5.0	-	5.0	-	9.0	-	-			
	1255N				●													-	12.7	5.5	-	5.0	-	10.0	-	-			
	1260N																	-	12.7	6.0	-	5.0	-	11.0	-	-			
	1265N				●	●												-	12.7	6.5	-	5.0	-	12.0	-	-			
	1270N																	-	12.7	7.0	-	5.0	-	13.0	-	-			
1275N				●													-	12.7	7.5	-	5.0	-	14.0	-	-				
1285N																	-	12.7	8.5	-	5.0	-	16.0	-	-				
	1223N-C03																	-	12.7	2.3	-	5.0	-	4.0	-	-		E243	
	1230N-C03																	-	12.7	3.0	-	5.0	-	5.0	-	-		E244	
	1235N-C03																	-	12.7	3.5	-	5.0	-	6.0	-	-			
	1240N-C05																	-	12.7	4.0	-	5.0	-	7.0	-	-			
	1245N-C05																	-	12.7	4.5	-	5.0	-	8.0	-	-			
	1250N-C05																	-	12.7	5.0	-	5.0	-	9.0	-	-			
	1255N-C05																	-	12.7	5.5	-	5.0	-	10.0	-	-			
	1260N-C05																	-	12.7	6.0	-	5.0	-	11.0	-	-			
	1265N-C05																	-	12.7	6.5	-	5.0	-	12.0	-	-			
1270N-C05																	-	12.7	7.0	-	5.0	-	13.0	-	-				
1275N-C05																	-	12.7	7.5	-	5.0	-	14.0	-	-				
	16																	15.8	16	3.5	8	-	-	-	-	-		E199	
	20																	17.8	20	4	10	-	-	-	-	-			
	25																	22.0	25	5	12.5	-	-	-	-	-			
	30																	26.8	30	6	15	-	-	-	-	-			
	32																	27.8	32	6	16	-	-	-	-	-			
	10T3M0-MA																	-	10	3.97	-	3.85	-	-	-	-		E154	
	1204M0-MA																	-	12	4.76	-	4.5	-	-	-	-		E155	
																												E160	
																												E161	
																												E165	
	0501M0F																	-	5	1.59	-	2.3	-	-	-	-		E158	
	0501M0E																	-	5	1.59	-	2.3	-	-	-	-		E159	
	0501M0S																	-	5	1.59	-	2.3	-	-	-	-		E164	
	06T1M0F																	-	6	1.98	-	2.5	-	-	-	-		E165	
	06T1M0E																	-	6	1.98	-	2.5	-	-	-	-			
	06T1M0S																	-	6	1.98	-	2.5	-	-	-	-			
	0702M0F																	-	7	2.38	-	2.8	-	-	-	-			
	0702M0E																	-	7	2.38	-	2.8	-	-	-	-			
	0702M0S																	-	7	2.38	-	2.8	-	-	-	-			
	0803M0F																	-	8	3.18	-	3.4	-	-	-	-			
0803M0E																	-	8	3.18	-	3.4	-	-	-	-				
0803M0S																	-	8	3.18	-	3.4	-	-	-	-				

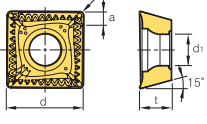
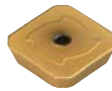
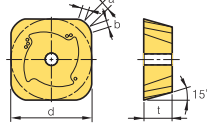
● : Наличие на складе

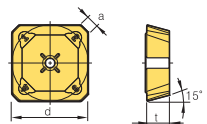
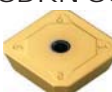
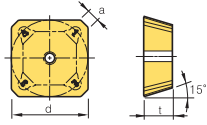
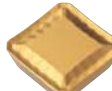
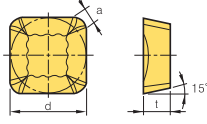
СМП	Обозначение	Твердые сплавы с покрытием											Керметы			Твердые сплавы			Размеры СМП (мм)						Геометрия	применяемые корпуса фрез, стр.																																																																																																																																																																																																			
		NCM325	NCM335	NC5330	PC3500	PC5300	PC3945	PC9530	PC6510	PC215K	PD2000	CN2000	CN20	CN30	H01	G10	ST30A	ST20	l	d	t	r	d ₁	a																																																																																																																																																																																																					
		<table border="1"> <tr><td>Стали</td><td>P</td><td>•</td><td>•</td><td>•</td><td>•</td><td>•</td><td>•</td><td>•</td><td>•</td><td>•</td><td>•</td><td>•</td><td>•</td><td>•</td><td>•</td><td>•</td><td>•</td><td>•</td><td>•</td><td>•</td><td>•</td><td>•</td><td>•</td><td>•</td><td>•</td><td>•</td><td>•</td><td>•</td><td>•</td></tr> <tr><td>Нержавеющие стали</td><td>M</td><td>•</td><td>•</td><td>•</td><td>•</td><td>•</td><td>•</td><td>•</td><td>•</td><td>•</td><td>•</td><td>•</td><td>•</td><td>•</td><td>•</td><td>•</td><td>•</td><td>•</td><td>•</td><td>•</td><td>•</td><td>•</td><td>•</td><td>•</td><td>•</td><td>•</td><td>•</td><td>•</td><td>•</td><td>•</td></tr> <tr><td>Чугуны</td><td>K</td><td>•</td><td>•</td><td>•</td><td>•</td><td>•</td><td>•</td><td>•</td><td>•</td><td>•</td><td>•</td><td>•</td><td>•</td><td>•</td><td>•</td><td>•</td><td>•</td><td>•</td><td>•</td><td>•</td><td>•</td><td>•</td><td>•</td><td>•</td><td>•</td><td>•</td><td>•</td><td>•</td><td>•</td><td>•</td></tr> <tr><td>Цветные металлы</td><td>N</td><td>•</td><td>•</td><td>•</td><td>•</td><td>•</td><td>•</td><td>•</td><td>•</td><td>•</td><td>•</td><td>•</td><td>•</td><td>•</td><td>•</td><td>•</td><td>•</td><td>•</td><td>•</td><td>•</td><td>•</td><td>•</td><td>•</td><td>•</td><td>•</td><td>•</td><td>•</td><td>•</td><td>•</td><td>•</td></tr> <tr><td>Жаропрочные сплавы, титан</td><td>S</td><td>•</td><td>•</td><td>•</td><td>•</td><td>•</td><td>•</td><td>•</td><td>•</td><td>•</td><td>•</td><td>•</td><td>•</td><td>•</td><td>•</td><td>•</td><td>•</td><td>•</td><td>•</td><td>•</td><td>•</td><td>•</td><td>•</td><td>•</td><td>•</td><td>•</td><td>•</td><td>•</td><td>•</td><td>•</td></tr> <tr><td>Материалы с повышенной твердостью</td><td>H</td><td>•</td><td>•</td><td>•</td><td>•</td><td>•</td><td>•</td><td>•</td><td>•</td><td>•</td><td>•</td><td>•</td><td>•</td><td>•</td><td>•</td><td>•</td><td>•</td><td>•</td><td>•</td><td>•</td><td>•</td><td>•</td><td>•</td><td>•</td><td>•</td><td>•</td><td>•</td><td>•</td><td>•</td><td>•</td></tr> </table>																	Стали	P	•	•	•	•	•	•	•	•	•	•	•	•	•	•	•	•	•	•	•	•	•	•	•	•	•	•	•	•	Нержавеющие стали	M	•	•	•	•	•	•	•	•	•	•	•	•	•	•	•	•	•	•	•	•	•	•	•	•	•	•	•	•	•	Чугуны	K	•	•	•	•	•	•	•	•	•	•	•	•	•	•	•	•	•	•	•	•	•	•	•	•	•	•	•	•	•	Цветные металлы	N	•	•	•	•	•	•	•	•	•	•	•	•	•	•	•	•	•	•	•	•	•	•	•	•	•	•	•	•	•	Жаропрочные сплавы, титан	S	•	•	•	•	•	•	•	•	•	•	•	•	•	•	•	•	•	•	•	•	•	•	•	•	•	•	•	•	•	Материалы с повышенной твердостью	H	•	•	•	•	•	•	•	•	•	•	•	•	•	•	•	•	•	•	•	•	•	•	•	•	•	•	•	•	•	Условия резания						•	•	•	Непрерывное	•	•	•	Универсальное	•	•	•	Прерывистое
Стали	P	•	•	•	•	•	•	•	•	•	•	•	•	•	•	•	•	•	•	•	•	•	•	•	•	•	•	•	•																																																																																																																																																																																																
Нержавеющие стали	M	•	•	•	•	•	•	•	•	•	•	•	•	•	•	•	•	•	•	•	•	•	•	•	•	•	•	•	•	•																																																																																																																																																																																															
Чугуны	K	•	•	•	•	•	•	•	•	•	•	•	•	•	•	•	•	•	•	•	•	•	•	•	•	•	•	•	•	•																																																																																																																																																																																															
Цветные металлы	N	•	•	•	•	•	•	•	•	•	•	•	•	•	•	•	•	•	•	•	•	•	•	•	•	•	•	•	•	•																																																																																																																																																																																															
Жаропрочные сплавы, титан	S	•	•	•	•	•	•	•	•	•	•	•	•	•	•	•	•	•	•	•	•	•	•	•	•	•	•	•	•	•																																																																																																																																																																																															
Материалы с повышенной твердостью	H	•	•	•	•	•	•	•	•	•	•	•	•	•	•	•	•	•	•	•	•	•	•	•	•	•	•	•	•	•																																																																																																																																																																																															
RDHW 	1605MOF																	-	16	5.56	-	5.5	-		E156																																																																																																																																																																																																				
	1605MOE																	-	16	5.56	-	5.5	-		E158																																																																																																																																																																																																				
	1605MOS																	-	16	5.56	-	5.5	-		E162																																																																																																																																																																																																				
	2006MOF																	-	20	6.35	-	5.5	-		E163																																																																																																																																																																																																				
	2006MOE																	-	20	6.35	-	5.5	-																																																																																																																																																																																																						
	2006MOS																	-	20	6.35	-	5.5	-																																																																																																																																																																																																						
RDKT-MF 	10T3MO-MF				•	•	•											-	10	3.97	-	3.85	-		E154																																																																																																																																																																																																				
	1204MO-MF			•	•	•	•											-	12	4.76	-	4.5	-		E155																																																																																																																																																																																																				
	1605MO-MF																	-	16	5.56	-	5.5	-		E160 E161 E165																																																																																																																																																																																																				
RDKT-ML 	1605MO-ML																	-	16	5.56	-	5.5	-		E156 E158 E162 E163																																																																																																																																																																																																				
RDKT-MM 	10T3MO-MM	•	•	•	•	•	•											-	10	3.97	-	3.85	-		E154-E157																																																																																																																																																																																																				
	1204MO-MM	•	•	•	•	•	•											-	12	4.76	-	4.5	-		E160-E165																																																																																																																																																																																																				
	1605MO-MM			•	•													-	16	5.56	-	5.5	-																																																																																																																																																																																																						
	2006MO-MM			•	•													-	20	6.35	-	5.5	-																																																																																																																																																																																																						
RDKW 	0501MOE				•													-	5	1.59	-	2.3	-		E158																																																																																																																																																																																																				
	06T1MOE				•													-	6	1.98	-	2.5	-		E159																																																																																																																																																																																																				
	0702MOE				•													-	7	2.38	-	2.8	-		E164																																																																																																																																																																																																				
	0803MOE				•													-	8	3.18	-	3.4	-																																																																																																																																																																																																						
REKR-MM 	170400-MM																	-	17.8	4.76	-	-	-		E48																																																																																																																																																																																																				
SDCN 	42R																	-	12.7	3.18	-	-	3.5		E261																																																																																																																																																																																																				
	42L																	-	12.7	3.18	-	-	3.5		E262																																																																																																																																																																																																				
	53R																	-	15.875	4.76	-	-	5.0																																																																																																																																																																																																						
	53L																	-	15.875	4.76	-	-	5.0																																																																																																																																																																																																						
	42M															•		-	12.7	3.18	-	-	1.5		E34																																																																																																																																																																																																				
	42M-G														•			-	12.7	3.18	-	-	1.5		E35																																																																																																																																																																																																				
	42MT	•									•	•			•	•		-	12.7	3.18	-	-	1.5		E44																																																																																																																																																																																																				
	42MT-RH			•														-	12.7	3.18	-	-	1.5		E46																																																																																																																																																																																																				
	42MT-S20							•										-	12.7	3.18	-	-	1.5		E261																																																																																																																																																																																																				
	53M															•		-	15.875	4.76	-	-	1.5		E262																																																																																																																																																																																																				
	53M-G															•		-	15.875	4.76	-	-	1.5																																																																																																																																																																																																						
	53MT	•	•								•	•			•	•		-	15.875	4.76	-	-	1.5																																																																																																																																																																																																						
	53MT-RH				•													-	15.875	4.76	-	-	1.5																																																																																																																																																																																																						
	53MT-S20								•									-	15.875	4.76	-	-	1.5																																																																																																																																																																																																						
	1203AEEN																	-	12.7	3.18	-	-	1.5																																																																																																																																																																																																						
	1203AEEN-RH																	-	12.7	3.18	-	-	1.43																																																																																																																																																																																																						
	1203AESN																	-	12.7	3.18	-	-	1.5																																																																																																																																																																																																						
	1203AESN-RH																	-	12.7	3.18	-	-	1.43																																																																																																																																																																																																						
	1504AEEN																	-	15.875	4.76	-	-	1.5																																																																																																																																																																																																						
	1504AEEN-RH					•		•										-	15.875	4.76	-	-	1.43																																																																																																																																																																																																						
1504AESN																	-	15.875	4.76	-	-	1.5																																																																																																																																																																																																							
1504AESN-RH																	-	15.875	4.76	-	-	1.43																																																																																																																																																																																																							
SDET-MA 	09M402R-MA									•				•			-	9.525	3.923	0.2	4.0	1.2		E148-E153																																																																																																																																																																																																					
	09M404R-MA																-	9.525	3.923	0.4	4.0	1.2																																																																																																																																																																																																							
	09M405R-MA																-	9.525	3.923	0.5	4.0	1.2																																																																																																																																																																																																							
	130504R-MA																-	13.5	5.56	0.4	5.56	2.2																																																																																																																																																																																																							
																		-																																																																																																																																																																																																											

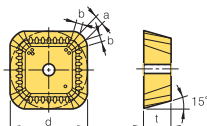
• : Наличие на складе

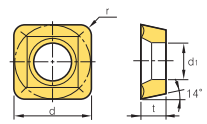
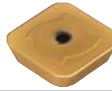
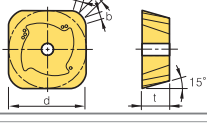
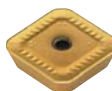
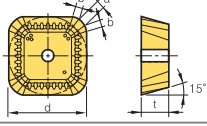

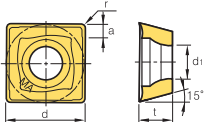
Обрабатываемые материалы	Условия резания								
	Стали	Нержавеющие стали	Чугуны	Цветные металлы	Жаропрочные сплавы, титан	Материалы с повышенной твердостью	● Непрерывное	● Универсальное	● Прерывистое
	P	M	K	N	S	H			

СМП	Обозначение	Твердые сплавы с покрытием			Керметы	Твердые сплавы	Размеры СМП (мм)					Геометрия	применяемые корпусы фрез, стр.																			
		NCM325	NCM335	NG5330			PC3500	PC3600	PC3545	PC3530	PC6510			PC215K	PD2000	CN2000	CN20	CN30	H01	G10	ST30A	ST20	l	d	t	r	d ₁	a	b			
 SDET-MF	09M405R-MF																						-	9.525	4	0.5	4	1.2	-		E148 ~E153	
	130508R-MF																						-	13.5	5.56	0.8	5.56	2.2	-			
 SDET-MM	09M405R-MM																						-	9.525	4	0.5	4	1.2	-		E148 ~E153	
	130508R-MM																						-	13.5	5.56	0.8	5.56	2.2	-			
 SDKN-SM	1203AESN-SM																						-	12.7	3.18	-	-	1.64	0.59		E34 E35 E44 E45	
	1203AEEN-SM																						-	12.7	3.18	-	-	1.64	0.59			
	1504AESN-SM																						-	15.875	4.76	-	-	1.64	0.58			
	1504AEEN-SM																						-	15.875	4.76	-	-	1.64	0.58			
 SDKN-MU	1203AESN-MU			●																			-	12.7	3.18	-	-	2.08	-		E34 E35 E44 E45	
	1504AESN-MU			●																			-	15.875	4.76	-	-	2.10	-			
 SDKN-SU	1203AESN-SU				●	●	●																-	12.7	3.18	-	-	2.08	-		E34 E35 E44 E45	
	1504AESN-SU				●	●																	-	15.875	4.76	-	-	2.10	-			
 SDKR-MX	1203AESN-MX																						-	12.7	3.18	-	-	1.46	-		E34 E35 E44 E45	
	1203AETN-MX																						-	12.7	3.18	-	-	1.46	-			
	1203AEN-MX	●																					-	12.7	3.18	-	-	1.46	-			
	1504AESN-MX		●																				-	15.875	4.76	-	-	1.45	-			
	1504AETN-MX																						-	15.875	4.76	-	-	1.45	-			
	1504AEN-MX	●																					-	15.875	4.76	-	-	1.45	-			
 SDKR-SM	1203AESN-SM																						-	12.7	3.18	-	-	1.43	0.71		E34 E35 E44 E45	
	1504AESN-SM																						-	15.875	4.76	-	-	1.64	0.58			
 SDMT-MM	090308-MM			●																			-	9.525	3.18	0.8	4.4	-	-		E186 E200	
 SDXN-FM	1203AESN-FM																						-	12.7	3.18	-	-	1.43	0.71		E34 E35 E44 E45	
	1203AEEN-FM																						-	12.7	3.18	-	-	1.43	0.71			
	1504AESN-FM																						-	15.875	4.76	-	-	1.43	0.70			
	1504AEEN-FM																						-	15.875	4.76	-	-	1.43	0.70			
 SDXR-FM	1203AESN-FM																						-	12.7	3.18	-	-	1.43	0.71		E34 E35 E44 E45	
	1504AESN-FM																						-	15.875	4.76	-	-	1.43	0.70			
 SDXT-MA	09M405R-MA																							●	9.525	4.0	0.5	4.0	1.2	-		E148 ~E153
	130508R-MA																							●	13.5	5.56	0.8	5.56	2.2	-		

● : Наличие на складе



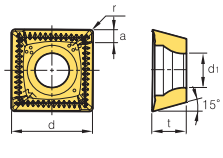
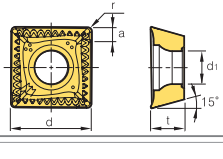
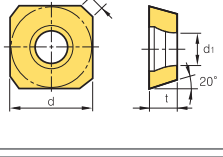
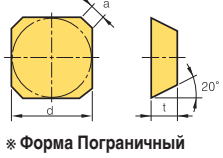
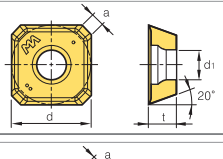
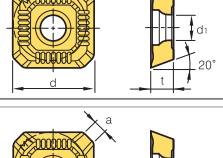
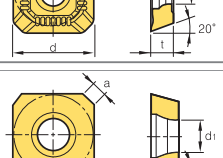
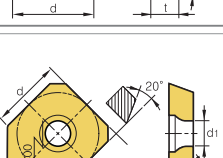







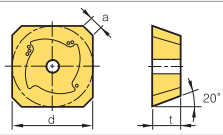
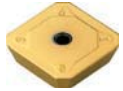
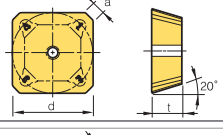
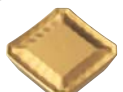
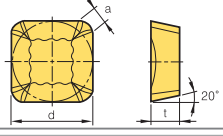

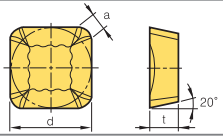

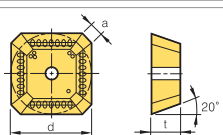

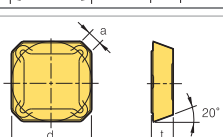

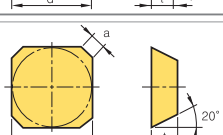
Обрабатываемые материалы	Стали	P	●	●	●	●	●	●	●	●	●	●	●	●	●	●	●	●	●	●
	Нержавеющие стали	M	●	●	●	●	●	●	●	●	●	●	●	●	●	●	●	●	●	●
	Чугуны	K	●	●	●	●	●	●	●	●	●	●	●	●	●	●	●	●	●	●
	Цветные металлы	N	●	●	●	●	●	●	●	●	●	●	●	●	●	●	●	●	●	●
	Жаропрочные сплавы, титан	S	●	●	●	●	●	●	●	●	●	●	●	●	●	●	●	●	●	●
Материалы с повышенной твердостью	H	●	●	●	●	●	●	●	●	●	●	●	●	●	●	●	●	●	●	●

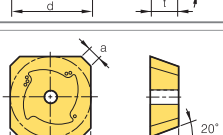
Условия резания ● Непрерывное
 ● Универсальное
 ● Прерывистое

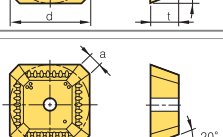
СМП	Обозначение	Твердые сплавы с покрытием										Керметы		Твердые сплавы		Размеры СМП (мм)					Геометрия	применяемые корпуса фрез, стр.			
		NCM325	NCM335	NC5330	PC3500	PC5300	PC5400	PC3545	PC9530	PC6510	PD2000	CN2000	CN20	CN30	H01	G10	ST30A	ST20	l	d			t	r	d ₁
SDXT-MF	09M403R-MF																	-	9.525	4.0	0.3	4.0	1.2		E148 ~E153
	09M403L-MF																	-	9.525	4.0	0.3	4.0	1.2		
	09M404R-MF																	-	9.525	4.0	0.4	4.0	1.2		
	09M404L-MF																	-	9.525	4.0	0.4	4.0	1.2		
	09M405R-MF	●	●		●	●		●	●									-	9.525	4.0	0.5	4.0	1.2		
	130508R-MF	●	●		●	●		●										-	13.5	5.56	0.8	5.56	2.2		
SDXT-MM	09M405R-MM	●	●	●	●	●											-	9.525	4.0	0.5	4.0	1.2		E148 ~E153	
	09M405L-MM	●	●	●	●	●											-	9.525	4.0	0.5	4.0	1.2			
	130508R-MM	●	●		●	●	●										-	13.5	5.56	0.8	5.56	2.2			
	130508L-MM	●	●		●	●	●										-	13.5	5.56	0.8	5.56	2.2			
SECA	1204AFSN	●	●														-	12.7	4.76	-	5.56	2.66		-	
	1204AFTN		●									●					-	12.7	4.76	-	5.56	2.66			
	1204AFFN																-	12.7	4.76	-	5.56	2.66			
	1204AFEN																-	12.7	4.76	-	5.56	2.66			
	1504AFSN																-	15.875	4.76	-	5.5	2.8			
	1504AFTN																-	15.875	4.76	-	5.5	2.8			
SECN	1203AFFN													●	●		-	12.7	3.18	-	-	2.36	 <p>* Форма Пограничный · S20 : STS</p>	E36 E37	
	1203AFTN												●	●	●	●	-	12.7	3.18	-	-	2.36			
	1203AFEN																-	12.7	3.18	-	-	2.36			
	1203AFSN	●	●														-	12.7	3.18	-	-	2.36			
	1203AFEN-RH				●				●								-	12.7	3.18	-	-	2.36			
	1203AFSN-RH																-	12.7	3.18	-	-	2.36			
	1203AFTN-S20																-	12.7	3.18	-	-	2.36			
	1504AFFN															●	-	15.875	4.76	-	-	2.4			
	1504AFTN														●	●	-	15.875	4.76	-	-	2.4			
	1504AFEN																-	15.875	4.76	-	-	2.4			
	1504AFSN	●	●														-	15.875	4.76	-	-	2.4			
	1504AFEN-RH																-	15.875	4.76	-	-	2.4			
1504AFSN-RH															●	-	15.875	4.76	-	-	2.4				
1504AFTN-S20																-	15.875	4.76	-	-	2.4				
SEET-MA	0903AGFN-MA														●	-	9.525	3.18	-	3.4	2.11		E142 ~E147		
	14M4AGFN-MA														●	-	14.0	4.0	-	4.4	2.64				
SEET-MF	0903AGSN-MF	●													●	-	9.525	3.18	-	3.4	2.11		E142 ~E147		
	14M4AGSN-MF	●	●		●										●	-	14.0	4.0	-	4.4	2.64				
SEET-MM	0903AGSN-MM	●			●											-	9.525	3.18	-	3.4	2.11		E142 ~E147		
	14M4AGSN-MM	●	●		●										●	-	14.0	4.0	-	4.4	2.64				
SEEW	0903AGTN															-	9.525	3.18	-	3.4	2.11		E142 ~E147		
	14M4AGTN														●	-	14.0	4.0	-	4.4	2.64				
SEEW-W	14M4AGFN-W															-	14.0	4.0	-	4.4	8.5		E142 E143 E145 E146 E147		
	14M4AGSN-W															-	14.0	4.0	-	4.4	8.5				
	14M4AGTN-W															-	14.0	4.0	-	4.4	8.5				
																-	14.0	4.0	-	4.4	8.5				

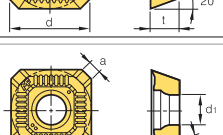
● : Наличие на складе

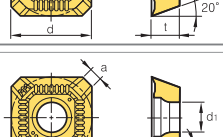

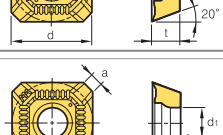
Обрабатываемые материалы	Условия резания													Геометрия	применяемые корпуса фрез, стр.											
	Стали	Нержавеющие стали	Чугуны	Цветные металлы	Жаропрочные сплавы, титан	Материалы с повышенной твердостью	●	●	●	●	●	●	●			●	●	●								
СМП	Обозначение	Твердые сплавы с покрытием							Керметы		Твердые сплавы			Размеры СМП (мм)						Геометрия	применяемые корпуса фрез, стр.					
		NCM325	NCM335	NC5330	PC3500	PC3600	PC5300	PC5400	PC3545	PC9530	PC6510	PC215K	CN2000	CN20	CN30	H01	G10	ST30A	l			d	t	d ₁	a	b
	1203AFSN-SM																		-	12.7	3.18	-	2.46	-		E36 E37
	1203AFEN-SM																		-	12.7	3.18	-	2.46	-		
	1504AFSN-SM									●									-	15.875	4.76	-	2.50	-		
	1504AFEN-SM																		-	15.875	4.76	-	2.50	-		
	1203AFSN-SU																		-	12.7	3.18	-	1.98	-		E36 E37
	1504AFSN-SU																		-	15.875	4.76	-	2.04	-		
	1203AFSN-MF1																		-	12.7	3.18	-	2.3	-		E36 E37
	1203AFSN-MX																		-	12.7	3.18	-	2.3	-		E36 E37
	1204AFSN-MX																		-	12.7	4.76	-	2.3	-		
	1504AFSN-MX																		-	15.875	4.76	-	2.4	-		
	1203AFSN-SM																		-	12.7	3.18	-	2.46	-		E36 E37
	1504AFSN-SM																		-	15.875	4.76	-	2.50	-		
	1203AFSN-X35																		-	12.7	3.18	-	2.361	-		E36
	1203AFFN-X35																		-	12.7	3.18	-	2.361	-		
	1204AFFN-X35																		-	12.7	4.76	-	2.361	-		
	1204AZ																		-	12.7	4.76	-	2.0	-		E36
	1203AFSN-FM																		-	12.7	3.18	-	2.36	-		E36 E37
	1203AFEN-FM																		-	12.7	3.18	-	2.36	-		
	1504AFSN-FM																		-	15.875	4.76	-	2.40	-		
	1504AFEN-FM																		-	15.875	4.76	-	2.40	-		
	1203AFSN-FM																		-	12.7	3.18	-	2.36	-		E36 E37
	1504AFSN-FM																		-	15.875	4.76	-	2.40	-		
	0903AGSN-MF																		-	9.525	3.18	3.4	2.11	-		E142 ~E147
	14M4AGSN-MF																		-	14.0	4.0	4.4	2.64	-		
	0903AGSN-MM																		-	9.525	3.18	3.4	2.11	-		E142 ~E147
	14M4AGSN-MM																		-	14.0	4.0	4.4	2.64	-		
	0903AGSN-MR																		-	9.525	3.18	3.4	2.11	-		E142 ~E147
	14M4AGSN-MR																		-	14.0	4.0	4.4	2.64	-		

● : Наличие на складе



Обработываемые материалы	Стали	P	●	●	●	●	●	●	●	●	●	●	●	●							
	Нержавеющие стали	M	●	●	●	●	●	●	●	●	●	●	●	●							
	Чугуны	K	●	●	●	●	●	●	●	●	●	●	●	●							
	Цветные металлы	N	●	●	●	●	●	●	●	●	●	●	●	●							
	Жаропрочные сплавы, титан	S	●	●	●	●	●	●	●	●	●	●	●	●							
Материалы с повышенной твердостью	H	●	●	●	●	●	●	●	●	●	●	●	●								









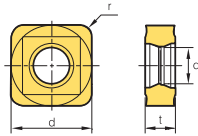
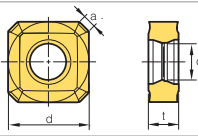

Условия резания

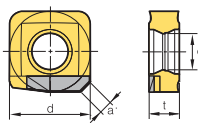
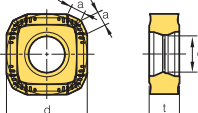
- Непрерывное
- Универсальное
- Прерывистое

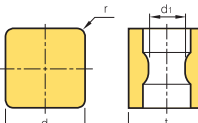
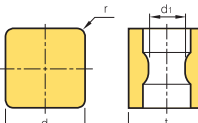
СМП	Обозначение	Твердые сплавы с покрытием										Керметы			Твердые сплавы				Размеры СМП (мм)						Геометрия	применяемые корпусы фрез, стр.				
		NCM325	NCM335	NC5330	PC3500	PC5300	PC3545	PC9530	PC6510	PC215K	PD2000	CN2000	CN30	G10	ST30A	ST20	l	d	t	r	d _i	a	b							
SFCN	1203EFR																	●	●		-	12.7	3.18	-	-	2.5	-			E38
SNC(M)F-MF	SNCF 1206ANN-MF																				-	12.7	6.6	-	-	2	-			E72
	1507ANN-MF								●												-	15.875	7.35	-	-	2.1	-			E73
	SNMF 1206ANN-MF																				-	12.7	6.6	-	-	2	-			
	1507ANN-MF																				-	15.875	7.35	-	-	2.1	-			
	SNCF 1206ENN-MF									●											-	12.7	6.6	-	-	1.8	-			E74
	1507ENN-MF								●												-	15.875	7.35	-	-	1.8	-			E75
SNMF 1206ENN-MF									●											-	12.7	6.6	-	-	1.8	-				
1507ENN-MF									●											-	15.875	7.35	-	-	1.8	-				
SNC(M)F-MM	SNCF 1206QNN-MF			●					●											-	12.7	6.6	0.8	-	1	-			E76	
	SNMF 1206QNN-MF			●																-	12.7	6.6	0.8	-	1	-				
SNC(M)F-MM	SNCF 1206ANN-MM			●																-	12.7	6.6	-	-	2	-			E72	
	1507ANN-MM			●		●														-	15.875	7.35	-	-	2.1	-			E73	
	SNMF 1206ANN-MM																			-	12.7	6.6	-	-	2	-				
	1507ANN-MM					●														-	15.875	7.35	-	-	2.1	-				
SNC(M)F-MM	SNCF 1206ENN-MM			●		●														-	12.7	6.6	-	-	1.8	-			E74	
	1507ENN-MM					●														-	15.875	7.35	-	-	1.8	-			E75	
	SNMF 1206ENN-MM			●																-	12.7	6.6	-	-	1.8	-				
	1507ENN-MM			●																-	15.875	7.35	-	-	1.8	-				
SNC(M)F-MM	SNCF 1206QNN-MM			●		●		●												-	12.7	6.6	0.8	-	1	-			E76	
	SNMF 1206QNN-MM			●																-	12.7	6.6	0.8	-	1	-				
SNCN	1204ENN		●										●	●	●					-	12.7	4.76	-	-	1.4	1.0			E39	
	1504ENN												●							-	15.875	4.76	-	-	1.4	1.0			E259 E260	
SNEF	435								●											-	12.7	4.76	2.0	-	-	-			E265	
	535																			-	15.875	4.76	2.0	-	-	-				

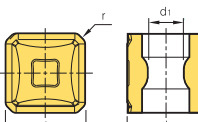
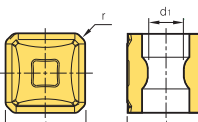
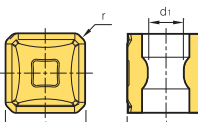
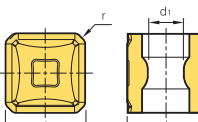

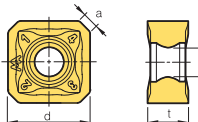
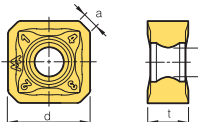
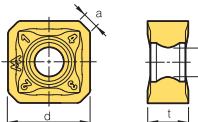
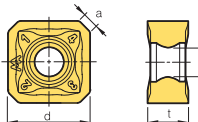
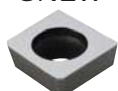
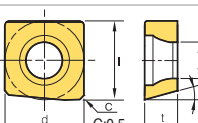
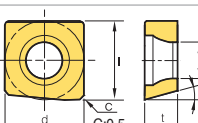
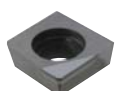
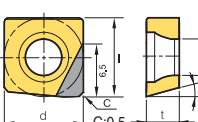
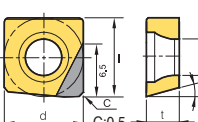

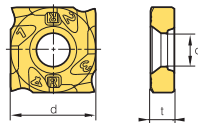
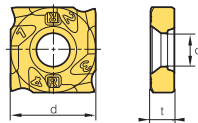
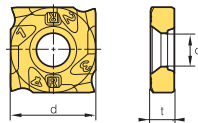
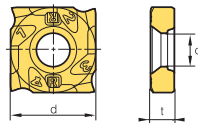
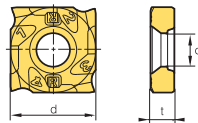
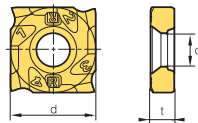
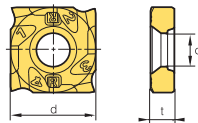
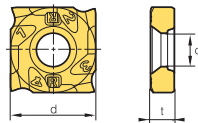
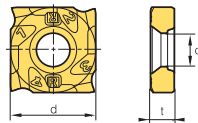
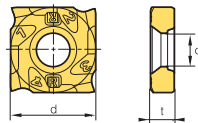
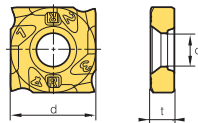
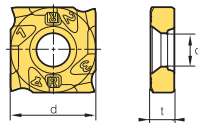



●: Наличие на складе

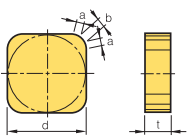

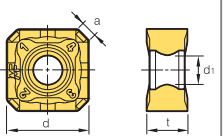
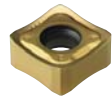
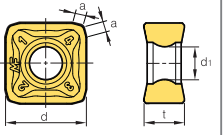
Обработываемые материалы	Условия резания										Геометрия	применяемые корпуса фрез, стр.																
	Стали	Нержавеющие стали	Чугуны	Цветные металлы	Жаропрочные сплавы, титан	Материалы с повышенной твердостью	● Непрерывное	● Универсальное	● Прерывистое																			
СМП	Обозначение	Твердые сплавы с покрытием						Керметы			СBN		Твердые сплавы		PCD		Размеры СМП (мм)					Геометрия						
		NCM325	NCM335	NC5330	PC3500	PC5300	PC3545	PC9530	PC6510	PC215K	CN2000	CN20	CN30	DBN700	DBN920	H01	G10	ST30A	DP200	l	d	t	r		d ₁	a	Геометрия	
	120420-MF								●										-	12.7	4.76	2.0	5.7	(2.3)			E267	
	1204ANN-MF																			-	12.7	4.76	-	5.7	(2.0)			E267
	1204-TBW																		-	12.7	4.76	-	5.7	(2.1)			E267	
	1204-WMF																			-	12.7	4.76	-	5.7	2.3			E267
	101010								●										-	10	10	1.0	4.6	-			E252	
	1010ZNN																		-	10	10	(1.0)	4.6	-			E252	
	101010-CU1								●										-	10	10	1.0	4.6	-			E256	
	1010ZNN-CU1								●										-	10	10	(1.0)	4.6	-			E256	
	121212-CU1								●										-	12.7	12.7	1.2	5.6	-			E256	
	1212ZNN-CU1								●										-	12.7	12.7	(1.2)	5.6	-			E256	
	1206ANN-MA																	●	-	12.7	6.35	-	4.5	2.36			E60~E69	
	1206ENN-MA							●										●	-	12.7	6.35	-	5.2	1.82			E60~E69	
	1206QNN-MA																	●	-	12.7	6.35	-	5.2	1.39			E60~E69	
	120612-MA																	●	-	12.7	6.35	1.2	5.2	-			E60~E69	
	09T3ADFR																	●	9.525	9.525	3.97	-	4.4	-			E81	
	09T3ADTR-XAF																	●	9.525	9.525	3.97	-	4.4	-			E81	
	09T3ADTR-NAF																	●	-	-	-	-	-	-			E81	
	09T3ADTR-NAF																	●	-	-	-	-	-	-			E81	
	1102308R/L-WX								●										-	11	2.30	-	4	-			E248	
	110308R/L-WX								●										-	11	3.00	-	5	-			E249	
	120308R/L-WX																		-	12.7	3.25	-	5.5	-			E249	
	1203508R/L-WX								●										-	12.7	3.50	-	6	-			E249	
	120408R/L-WX																		-	12.7	4.00	-	7	-			E249	
	1204508R/L-WX									●									-	12.7	4.54	-	8	-			E249	
	120508R/L-WX																		-	12.7	5.00	-	9	-			E249	
	1205408R/L-WX									●									-	12.7	5.47	-	10	-			E249	
	120608R/L-WX																		-	12.7	6.00	-	11	-			E249	
	1206508R/L-WX																		-	12.7	6.50	-	12	-			E249	
	120708R/L-WX																		-	12.7	7.00	-	13	-			E249	
1207508R/L-WX																		-	12.7	7.5	-	14	-			E249		

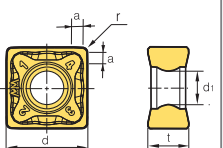
● : Наличие на складе

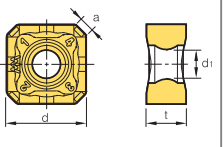
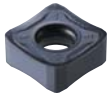
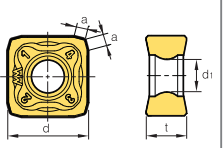
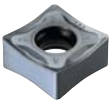
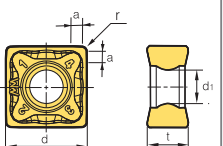

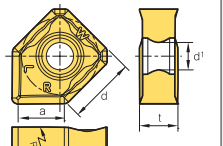





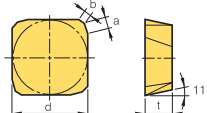

СМП	Обозначение	Твердые сплавы с покрытием										Керметы			Твердые сплавы		Размеры СМП (мм)						Геометрия	применяемые корпусы фрез, стр.	
		NCM325	NCM335	NC5330	PC3500	PC5300	PC5400	PC3545	PC9530	PC6510	CN2000	CN20	CN30	H01	G10	ST30A	ST20	l	d	t	r	d ₁			a
SNKN 	1204ENN																	12.7	4.76	-	-	1.4	1.0		E39 E259 E260
	1504ENN	●																15.875	4.76	-	-	1.4	1.0		
SNM(E)X-MF 	SNMX 1206ANN-MF			●	●	●		●										12.7	6.35	-	4.5	2.36	-		E60 E61 E65
	1507ANN-MF			●				●										15.875	7.94	-	5.6	3.15	-		
	SNEX 1206ANN-MF			●	●	●		●										12.7	6.35	-	4.5	2.36	-		
	1507ANN-MF			●				●										15.875	7.94	-	5.6	3.15	-		
SNM(E)X-MF 	SNMX 1206ENN-MF			●	●	●		●										12.7	6.35	-	4.5	1.82	-		E60 ~E64 E66 E67
	1507ENN-MF			●				●										15.875	7.94	-	5.6	2.66	-		
	SNEX 1206ENN-MF			●	●	●		●										12.7	6.35	-	4.5	1.82	-		
	1507ENN-MF			●				●										15.875	7.94	-	5.6	2.66	-		
SNM(E)X-MF 	SNMX 1206QNN-MF			●	●	●		●										12.7	6.35	-	5.2	2.36	-		E68 E69
	120612-MF			●				●										12.7	6.35	1.2	5.2	-	-		
	SNEX 1206QNN-MF			●	●	●		●										12.7	6.35	-	5.2	2.36	-		
SNM(E)X-MM 	SNMX 1206ANN-MM	●	●	●	●	●		●										12.7	6.35	-	4.5	2.36	-		E60 ~E64 E66 E67
	1507ANN-MM			●				●										15.875	7.94	-	5.6	3.15	-		
	SNEX 1206ANN-MM	●	●	●	●	●		●										12.7	6.35	-	4.5	2.36	-		
	1507ANN-MM			●				●										15.875	7.94	-	5.6	3.15	-		
SNM(E)X-MM 	SNMX 1206ENN-MM			●	●	●		●										12.7	6.35	-	5.2	1.82	-		E65
	1507ENN-MM			●				●										15.875	7.94	-	5.6	2.66	-		
	SNEX 1206ENN-MM			●	●	●		●										12.7	6.35	-	5.2	1.82	-		
	1507ENN-MM			●				●										15.875	7.94	-	5.6	2.66	-		
SNM(E)X-MM 	SNMX 1206QNN-MM			●	●	●		●										12.7	6.35	-	4.5	2.36	-		E68 E69
	120612-MM			●				●										12.7	6.35	1.2	4.5	-	-		
	SNEX 1206QNN-MM			●	●	●		●										12.7	6.35	-	4.5	2.36	-		
	120612-MM			●				●										12.7	6.35	1.2	4.5	-	-		
SNEX-W 	1206ANN-W			●				●										12.7	6.35	-	4.5	7.6	-		E60 E61

Условия резания ● Непрерывное
 ● Универсальное
 ✚ Прерывистое

●: Наличие на складе



Фрезерные СМП

Обрабатываемые материалы	Стали	● P	● M	● K	● N	● S	● H																Условия резания		Геометрия	применяемые корпуса фрез, стр.																											
	Нержавеющие стали	● M	● K	● N	● S	● H	● P	● M	● K	● N	● S	● H	● P	● M	● K	● N	● S	● H	● P	● M	● K	● N	● S	● H			● P	● M	● K	● N	● S	● H	● P	● M	● K	● N	● S	● H	● P	● M	● K	● N	● S	● H	● P	● M	● K	● N	● S	● H	● P	● M	● K
СМП	Обозначение	Твердые сплавы с покрытием								Керметы		Твердые сплавы					Размеры СМП (мм)					Геометрия																															
		NCM925	NCM830	PC5000	PC3600	PC5300	PC3545	PC9530	PC6510	PC215K	PD2000	CN2000	CN20	CN30	H01	G10	ST30A	ST20	l	d	t			r	d ₁	a	b																										
	1203EDR	●	●															●	●	●	●	●	-	12.7	3.18	-	-	1.4	1.0		E40 E41																						
	1203EDR-RH																						-	12.7	3.18	-	-	1.4	1.0																								
	1203EDL																					●	●	-	12.7	3.18	-	-	1.4			1.0																					
	1203EDR-G																					●		-	12.7	3.18	-	-	1.4			1.0																					
	1203EDER-RH																				●			-	12.7	3.18	-	-	1.63			0.8																					
	1203EDSR-RH																					●		-	12.7	3.18	-	-	1.63			0.8																					
	1203EDTR-RH																					●		-	12.7	3.18	-	-	1.63			0.8																					
	1203EDR-S20																					●		-	12.7	3.18	-	-	1.4			1.0																					
	1204EDR																							-	12.7	4.76	-	-	1.4			1.0																					
	150412T																							-	15.875	4.76	1.2	-	-			-	-																				
	1504EDR																					●	●	●	●	-	15.875	4.76	-			-	1.4	1.0																			
	1504EDR-RH																							-	15.875	4.76	-	-	1.4			1.0																					
	1504EDSR																					●		-	15.875	4.76	-	-	1.4			1.0																					
	1504EDL																					●		-	15.875	4.76	-	-	1.4			1.0																					
	1504EDR-G																					●		-	15.875	4.76	-	-	1.4			1.0																					
	1504EDER-RN																					●		-	15.875	4.76	-	-	1.4			1.0																					
1504EDER-RH																					●		-	15.875	4.76	-	-	1.64	0.8																								
1504EDSR-RH																					●		-	15.875	4.76	-	-	1.64	0.8																								
1504EDTR-RH																					●		-	15.875	4.76	-	-	1.64	0.8																								
1504EDR-S20																					●		-	15.875	4.76	-	-	1.4	1.0																								
	120416-WC																						-	12.7	4.76	1.6	-	-	-	-																							
	150412-WC																							-	15.875	4.76	1.2	-	-	-	-																						
	150416-WC																							-	15.875	4.76	1.6	-	-	-	-																						
	150420-WC																							-	15.875	4.76	2.0	-	-	-	-																						
	190424-WC																							-	19.05	4.76	2.4	-	-	-	-																						
	1203EDR-1																						-	12.7	3.18	-	-	10.2	-																								
	1203EDL-1																						-	12.7	3.18	-	-	10.2	-																								
	1504EDR-1																						-	15.875	4.76	-	-	10.2	-																								
	1504EDL-1																						-	15.875	4.76	-	-	10.2	-																								
	200-N																						8.8	2.2	-	0.2	-	-	-	-																							
	300-N																						9.8	3.0	-	0.2	-	-	-	-																							
	400-N																						9.8	4.0	-	0.25	-	-	-	-																							
	1203EDSR-SM																						-	12.7	3.18	-	-	1.66	0.92																								
	1203EDER-SM																						-	12.7	3.18	-	-	1.66	0.92																								
	1504EDSR-SM																						-	15.875	4.76	-	-	1.62	0.93																								
	1504EDER-SM																						-	15.875	4.76	-	-	1.62	0.93																								
	1203EDSR-MU																					●	-	12.7	3.18	-	-	0.86	1.87																								
	1504EDSR-MU																					●	-	15.875	4.76	-	-	0.84	1.92																								
	1203EDSR-SU																						-	12.7	3.18	-	-	1.66	0.92																								
	1203EDSL-SU																						-	12.7	3.18	-	-	1.66	0.92																								
	1504EDSR-SU																						-	15.875	4.76	-	-	1.62	0.93																								
	1504EDSL-SU																						-	15.875	4.76	-	-	1.62	0.93																								
	1203EDSR-MX																						●	●	●	-	12.7	3.18	-	-	1.4	-																					
	1203EDSL-MX																						●	●	●	-	12.7	3.18	-	-	1.4	-																					
	1504EDR-MX																						●	●	●	-	15.875	4.76	-	-	1.45	-																					
	1504EDSR-MX																						●	●	●	-	15.875	4.76	-	-	1.45	-																					
	1203EDSR-SM																						-	12.7	3.18	-	-	1.66	0.92																								
	1504EDSR-SM																						-	15.875	4.76	-	-	1.63	0.93																								

● : Наличие на складе



Обрабатываемые материалы	Условия резания																
	Стали	P			M			K			N			S		H	
Стали	●	●	●	●	●	●	●	●	●	●	●	●	●	●	●	●	●
Нержавеющие стали	●	●	●	●	●	●	●	●	●	●	●	●	●	●	●	●	●
Чугуны	●	●	●	●	●	●	●	●	●	●	●	●	●	●	●	●	●
Цветные металлы	●	●	●	●	●	●	●	●	●	●	●	●	●	●	●	●	●
Жаропрочные сплавы, титан	●	●	●	●	●	●	●	●	●	●	●	●	●	●	●	●	●
Материалы с повышенной твердостью	●	●	●	●	●	●	●	●	●	●	●	●	●	●	●	●	●

Условия резания ● Непрерывное
 ● Универсальное
 ● Прерывистое

СМП	Обозначение	Твердые сплавы с покрытием													Керметы		Твердые сплавы		Размеры СМП (мм)						Геометрия	применяемые корпусы фрез, стр.		
		NCM325	NCM335	NC5330	PC3500	PC5300	PC3545	PC6510	PC215K	PD2000	CN2000	CN20	CN30	H01	G10	ST30A	ST20	l	d	t	r	d _i	a	b				
SPMN	120308																●	-	12.7	3.18	0.8	-	-	-			E208	
SPMT	060304	●																-	6.35	3.18	0.4	2.8	-	-			E182 E197 E198	
SPMT-KC	110408-KC				●												● ●	-	11.5	4.8	0.8	4.5	-	-			E208	
SPMT-MM	120408-MM				●	●												-	12.7	4.76	0.8	5.6	-	-			E121 E182 E197 E198	
	120508-MMN																	-	12.7	5.56	0.8	5.6	-	-				
SPXN-FM	1203EDSR-FM																	-	12.7	3.18	-	-	1.41	1.00			E37 E38	
	1203EDER-FM																	-	12.7	3.18	-	-	1.41	1.00				
	1504EDSR-FM																	-	15.875	4.76	-	-	1.38	1.01				
	1504EDER-FM																	-	15.875	4.76	-	-	1.38	1.01				
SPXR-FM	1203EDSR-FM																	-	12.7	3.18	-	-	1.41	1.00			E37 E38	
	1504EDSR-FM																	-	15.875	4.76	-	-	1.38	1.01				
TEC(E)N	TECN 22R																●	11.0	6.35	3.18	-	-	1.0	0.5			E43	
	22TR																●	11.0	6.35	3.18	0.8	-	0.5	-				
	32R																●	16.5	9.525	3.18	-	-	1.0	0.5				
	32R-G	●															●	16.5	9.525	3.18	-	-	1.0	0.5				
	32TR																	●	16.5	9.525	3.18	0.8	-	0.5	-			
	32TR-S20																	●	16.5	9.525	3.18	0.8	-	0.5	-			
	43R-G						●											●	22.0	12.7	4.76	-	-	2.0	0.5			
	43TR-Z																	●	22.0	12.7	4.76	0.8	-	1.5	-			
TEEN	TEEN 32TR																●	16.5	9.525	3.18	0.8	-	0.5	-				
	43R-Z																●	22.0	12.7	4.76	-	-	2.0	0.5				
	43TR-Z																●	22.0	12.7	4.76	0.8	-	1.5	-				
	43TR-ZH						●										●	22.0	12.7	4.76	0.8	-	1.5	-				
	43R																●	22.0	12.7	4.76	-	-	2.0	0.5				
	43R-G																●	22.0	12.7	4.76	-	-	2.0	0.5				
TFCN	2203PFR																●	22.0	12.7	3.18	-	-	2.42	0.71			E39	
	2203PFL																●	22.0	12.7	3.18	-	-	2.42	0.71				
TNMX	2710AZNR-NM	●	●	●	●	●												27	15.875	10	0.8	5.6	2.63	-			E49 E50	
	2710AZNL-NM																	27	15.875	10	0.8	5.6	2.63	-				

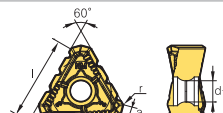
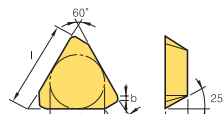
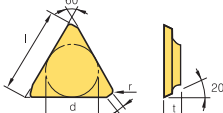
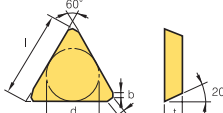
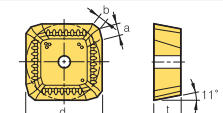
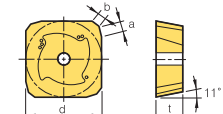
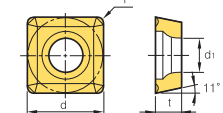
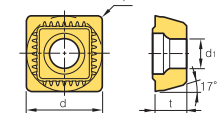
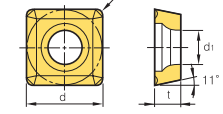
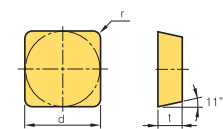

* Форма Пограничный
 · G : Светлая сторона,
 Форма Пограничный
 · S20 : STS
 · ZH : Отверстие добавлен









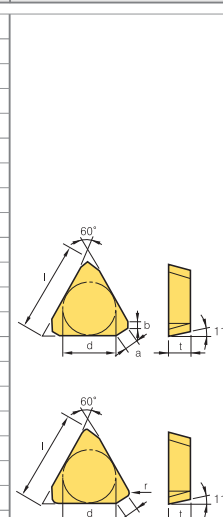

● : Наличие на складе

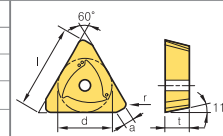
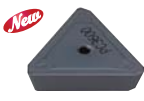
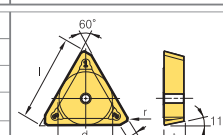
Фрезерные СМП

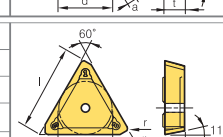
Обрабатываемые материалы	Совместимость													
	Стали	P		M		K		N		S		H		
Стали	●	●	●	●							●	●		●
Нержавеющие стали		●	●	●	●		●	●	●					●
Чугуны			●					●		●	●			●
Цветные металлы					●	●								●
Жаропрочные сплавы, титан					●	●								●
Материалы с повышенной твердостью					●	●								●

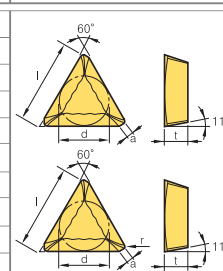
Условия резания

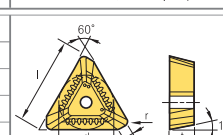
- Непрерывное
- Универсальное
- Прерывистое

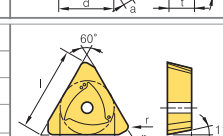
СМП	Обозначение	Твердые сплавы с покрытием												Керметы	Твердые сплавы		Размеры СМП (мм)						Геометрия	применяемые корпуса фрез, стр.					
		NCM325	NCM335	NC5330	PC3500	PC3600	PC5300	PC3545	PC9530	PC6510	PC8110	PD2000	CN20	CN30	HD1	G10	ST30A	ST20	l	d	t	r			d ₁	a	b		
TPCN 	1103PPN																	●	●	11.0	6.35	3.18	-	-	0.7	0.7		E40 E235 E236	
	1103PPTN																	●	●	11.0	6.35	3.18	-	-	0.7	0.7			
	1603PDR	●																		16.5	9.525	3.18	-	-	1.2	0.7			
	1603PPN	●																	●	●	16.5	9.525	3.18	-	-	1.2			1.2
	1603PPR	●																	●	●	16.5	9.525	3.18	-	-	1.2			1.0
	1603PPR-RH																			16.5	9.525	3.18	-	-	1.2	1.0			
	1603PPR-G																		●		16.5	9.525	3.18	-	-	1.2			1.0
	1603PPSR	●																		16.5	9.525	3.18	-	-	1.2	1.0			
	1603PPTN																			16.5	9.525	3.18	-	-	1.2	1.2			
	1603PPTR																			16.5	9.525	3.18	-	-	1.2	1.0			
	1603PPR-RH																			16.5	9.525	3.18	-	-	1.2	1.0			
	1603PDER-RH					●					●									16.5	9.525	3.18	0.8	-	1.5	-			
	1603PDSR-RH																			16.5	9.525	3.18	0.8	-	1.5	-			
	1603PDR-S20																			16.5	9.525	3.18	-	-	1.2	0.7			
	1603PDR-RN											●								16.5	9.525	3.18	-	-	1.5	1.1			
	2204PDR	●																	●	●	22.0	12.7	4.76	-	-	1.4			0.7
	2204PDR-RH																		●		22.0	12.7	4.76	-	-	1.4			0.7
	2204PDR-RN											●								22.0	12.7	4.76	-	-	1.42	0.52			
	2204PDR-G																		●		22.0	12.7	4.76	-	-	1.4			0.7
	2204PDL																			●	22.0	12.7	4.76	-	-	1.4			0.7
	2204PDSR	●																		22.0	12.7	4.76	-	-	1.4	0.7			
2204PDTR																			22.0	12.7	4.76	-	-	1.4	0.7				
2204PPN																			22.0	12.7	4.76	-	-	1.2	1.2				
2204PPTN																			22.0	12.7	4.76	-	-	1.2	1.2				
2204PDR-RH																			22.0	12.7	4.76	0.8	-	1.8	-				
2204PDER-RH						●				●	●								22.0	12.7	4.76	0.8	-	1.8	-				
2204PDSR-RH																			22.0	12.7	4.76	0.8	-	1.8	-				
2204PDR-S20																			22.0	12.7	4.76	-	-	1.4	0.7				
TPKN-SM 	1603PDSR-SM																		16.5	9.525	3.18	1.0	-	1.70	-		E40		
	1603PDER-SM																		16.5	9.525	3.18	1.0	-	1.70	-				
	2204PDSR-SM																		22.0	12.7	4.76	1.0	-	1.91	-				
	2204PDER-SM																		22.0	12.7	4.76	1.0	-	1.91	-				
TPKN-MU 	2204PDSR-MU																		22.0	12.7	4.76	0.8	-	1.96	-		E40		
TPKN-SU 	1603PDSL-SU																		16.5	9.525	3.18	1.0	-	1.70	-		E40		
	1603PDSR-SU					●	●												16.5	9.525	3.18	1.0	-	1.70	-				
	2204PDSL-SU						●	●											22.0	12.7	4.76	1.0	-	1.91	-				
	2204PDSR-SU							●	●										22.0	12.7	4.76	1.0	-	1.91	-				
TPKR-MX 	1603PDSN-MX																		16.5	9.525	3.18	-	-	1.2	1.2		E40		
	1603PDSR-MX																		16.5	9.525	3.18	-	-	1.2	0.7				
	1603PPR-MX	●																	16.5	9.525	3.18	-	-	1.2	1.0				
	1603PPSN-MX	●																	16.5	9.525	3.18	-	-	1.2	1.2				
	1603PPSR-MX	●																	16.5	9.525	3.18	-	-	1.2	1.0				
	2204PDR-MX	●																	22.0	12.7	4.76	1.0	-	1.4	-				
	2204PDSR-MX	●																	22.0	12.7	4.76	1.0	-	1.4	-				
2204PPR-MX																		22.0	12.7	4.76	1.0	-	1.4	-					
TPKR-SM 	1603PDSR-SM																		16.5	9.525	3.18	1.0	-	1.70	-		E40		
	2204PDSR-SM																		22.0	12.7	4.76	1.0	-	1.91	-				
TPXN-FM 	1603PDSR-FM					●	●												16.5	9.525	3.18	1.0	-	1.30	-		E40		
	1603PDER-FM																		16.5	9.525	3.18	1.0	-	1.30	-				
	2204PDSR-FM						●	●											22.0	12.7	4.76	1.0	-	1.51	-				
	2204PDER-FM																		22.0	12.7	4.76	1.0	-	1.51	-				

* TPC(K)N □□□P-N → Для FC HC
□□□P-R → Для Cutter (лицо)

● : Наличие на складе

Обрабатываемые материалы	Стали	P	●	●	●	●	●	●	●	●	●	●	●	●	●	●	●	●
	Нержавеющие стали	M	●	●	●	●	●	●	●	●	●	●	●	●	●	●	●	●
	Чугуны	K	●	●	●	●	●	●	●	●	●	●	●	●	●	●	●	●
	Цветные металлы	N	●	●	●	●	●	●	●	●	●	●	●	●	●	●	●	●
	Жаропрочные сплавы, титан	S	●	●	●	●	●	●	●	●	●	●	●	●	●	●	●	●
Материалы с повышенной твердостью	H	●	●	●	●	●	●	●	●	●	●	●	●	●	●	●	●	●

Условия резания ● Непрерывное
 ● Универсальное
 ● Прерывистое

СМП	Обозначение	Твердые сплавы с покрытием										Керметы		Твердые сплавы		Размеры СМП (мм)							Геометрия	применяемые корпуса фрез, стр.				
		NCM325	NCM335	NC5330	PC3500	PC5300	PC5400	PC3545	PC9530	PC6510	PD2000	CN2000	CN20	CN30	H01	G10	ST30A	ST20	l	l ₂	l ₁	d			t	r	d ₁	a
TPXR-FM	1603PDSR-FM							●										16.5	-	-	9.525	3.18	1.0	-	1.30	-		E43
	2204PDSR-FM						●											22.0	-	-	12.7	4.76	1.0	-	1.51	-		
TWX-KC	16R-KC			●														16.5	-	-	9.52	3.97	0.8	4.45	-	-		E210
	22R-KC			●														22.0	-	-	12.7	4.76	0.8	4.45	-	-		
VCKT-MA	220530N-MA														●			15.6	-	-	12.7	5.56	3.0	5.6	-	-		E224 E225
VDKT-MA	11T210N-MA														●			8.8	-	-	6.35	2.87	1.0	2.8	-	-		E224 E225
	11T220N-MA														●			6.7	-	-	6.35	2.87	2.0	2.8	-	-		
WDKT-MH	080316ZDSR-MH			●	●	●	●	●										-	-	-	8.0	3.18	1.6	3.3	-	1.8		E181 ~E185
	10T320ZDSR-MH			●	●	●	●	●										-	-	-	10.0	3.97	2.0	4.3	-	2.3		
	130520ZDSR-MH			●	●	●	●	●										-	-	-	13.5	5.56	2.0	5.56	-	3.1		
	150625ZDSR-MH			●	●	●	●	●	●									-	-	-	15.0	6.35	2.5	5.56	-	3.4		
WNMX-MM	060312ZNN-MM	Нов		●	●													-	-	-	6.35	3.18	1.2	2.86	-	1.2		E171 ~E180
	09T316ZNN-MM	Нов		●	●	●	●	●										-	-	-	9.525	3.97	1.6	3.6	-	1.7		
	130520ZNN-MM	Нов		●	●	●	●	●										-	-	-	12.7	5.56	2.0	4.7	-	2.5		
	160720ZNN-MM	Нов		●	●													-	-	-	16.0	7.0	2.0	5.8	-	3.0		
XCET-KC	310404ER-KC			●											●	●		30.9	-	-	9.525	4.5	0.4	4.4	-	-		E209
XEKT-MA	19M504FR-MA							●						●			18	16.4	1.4	-	5	0.4	4.4	-	-		E227 ~E232	
	19M508FR-MA							●						●			18	16.4	1.0	-	5	0.8	4.4	-	-			
	19M512FR-MA							●						●			18	16.4	0.6	-	5	1.2	4.4	-	-			
	19M516FR-MA							●						●			17.5	16.4	0.5	-	5	1.6	4.4	-	-			
	19M518FR-MA							●						●			17.5	16.4	0.5	-	5	1.8	4.4	-	-			
	19M520FR-MA							●						●			17.5	16.4	0.5	-	5	2.0	4.4	-	-			
	19M530FR-MA							●						●			17	16.4	0.7	-	5	3.0	4.4	-	-			
	19M532FR-MA							●						●			17	16.4	0.5	-	5	3.2	4.4	-	-			
	19M540FR-MA							●						●			16.5	16.4	0.5	-	5	4.0	4.4	-	-			
	19M550FR-MA							●						●			16	16.4	0.4	-	5	5.0	4.4	-	-			
	250604FR-MA							●						●			24.5	21.9	1.5	-	6.35	0.4	6.0	-	-			
	250608FR-MA							●						●			24.5	21.9	1.2	-	6.35	0.8	6.0	-	-			
	250612FR-MA							●						●			24.5	21.9	0.8	-	6.35	1.2	6.0	-	-			
	250616FR-MA							●						●			24.5	21.9	0.4	-	6.35	1.6	6.0	-	-			
	250620FR-MA							●						●			24	21.9	0.5	-	6.35	2.0	6.0	-	-			
	250630FR-MA							●						●			23.7	21.9	0.6	-	6.35	3.0	6.0	-	-			
250632FR-MA							●						●			23.7	21.9	0.4	-	6.35	3.2	6.0	-	-				
250640FR-MA							●						●			22.8	21.9	1.2	-	6.35	4.0	6.0	-	-				
250650FR-MA							●						●			22.7	21.9	0.4	-	6.35	5.0	6.0	-	-				

●: Наличие на складе











Обрабатываемые материалы	Условия резания											Условия резания		Геометрия	применяемые корпусы фрез, стр.													
	Стали	Нержавеющие стали	Чугуны	Цветные металлы	Жаропрочные сплавы, титан	Материалы с повышенной твердостью	●	●	●	●	●	●	●			●	●	●										
СМП	Обозначение	Твердые сплавы с покрытием			Керметы			Твердые сплавы			Размеры СМП (мм)						Геометрия	применяемые корпусы фрез, стр.										
		NCM325	NCM335	NC5330	PC3500	PC5300	PC3545	PC9530	PC6510	PC215K	PD2000	CN2000	CN20	CN30	H01	G10			ST30A	ST20	l	l ₂	l ₁	d	t	r	d ₁	f
ZDMT-R-MM	080310R-MM		●															8.4	-	-	6.73	3.2	10	2.8	-		E202	
	110312.5R-MM		●															10.6	-	-	8.5	3.65	12.5	2.8	-			
	130416R-MM		●															13.2	-	-	10.5	4.76	16	4.4	-			
ZPET-MM Internal	080M-MM																	16	-	-	8.0	3.5	8	2.9	-		E200	
	100M-MM		●															19	-	-	10.4	4.5	10	3.4	-			
	125M-MM		●															24	-	-	12.9	5.3	12.5	4.5	-			
	150M-MM		●															28	-	-	15.4	7	15	5.6	-			
	160M-MM		●															28.5	-	-	16.4	7	16	5.6	-			
	200M-MM		●															38	-	-	20.7	8	20	6.6	-			
	250M-MM		●															48	-	-	25.9	9.5	25	8.6	-			
ZPET-MM External	080S-MM																	15	-	-	6.6	3.1	8	2.9	-		E201	
	100S-MM		●															15.5	-	-	8.4	3.8	10	3.4	-			
	125S-MM		●															20.5	-	-	10.7	4.5	12.5	4.5	-			
	150S-MM		●															25	-	-	12.4	6.5	15	5.6	-			
	160S-MM		●															26	-	-	13.4	6.5	16	5.6	-			
	200S-MM		●															32	-	-	16.7	7	20	6.6	-			
	250S-MM		●															40	-	-	20.7	8.5	25	8.6	-			
ZPMT-MM	1504PPSR-MM		●	●														15.9	-	-	12.7	4.76	-	5.6	-		E125 E186	
	1505PPSR-MMN		●															15.9	-	-	12.7	5.76	-	5.6	-			
ZPMT-R-MM	160520R-MM		●															16.1	-	-	12.7	5.56	20	5.6	-		E202	
	160525R-MM		●															16.9	-	-	12.7	5.56	25	5.6	-			
	160531.5R-MM		●															17.6	-	-	12.7	5.56	31.5	5.6	-			
ZPMT-R-MR	160525R-MR																	17.6	-	-	12.7	5.56	25	5.6	-		E202	

● : Наличие на складе





Назначение	Серия	Обозначение	Эскиз	Угол в плане	Диаметр фрезы, мм	Общие характеристики	Обработка					Стр.
							Плоскостей	Уступов	Пазов	Контуров	Тангенциальное врезание	
Фрезерование плоскостей	Mill-max	ADN(M) 4000/5000+		45°	Ø80~Ø315	Усиленная режущая кромка. Препятствие пакетированию стружки в стружечной канавке	●					E34 E35
		AE(M) 4000/5000		45°	Ø80~Ø315	Низкие силы резания	●					E36 E37
		EF(M) 4000		75°	Ø80~Ø315	Значительный передний угол, препятствующий наростообразованию и налипанию стружки	●					E38
		EN(M) 4000		75°	Ø80~Ø315	Экономичность за счет применения двухсторонних СМП	●					E39
		EPN(M) 4000/5000+		75°	Ø80~Ø315	Положительная геометрия, снижение сил резания	●					E40 E41
		PF(M) 4000		90°	Ø80~Ø315	Снижение сил резания за счет положительного осевого переднего угла	●	●	●			E42
		PPN(M) 4000		90°	Ø80~Ø315	Снижение сил резания за счет положительной геометрии	●	●	●			E43
	Turbo Mill	ADS 4000/5000		45°	Ø50~Ø63	Снижение вибраций за счет применения переменного шага зубьев	●					E44 E45
		PES 2000/3000/ 4000		90°	Ø20~Ø63	Снижение сил резания за счет высокого переднего угла	●	●	●			E46
	Double Mill	AFO(M)4000		45°	Ø80~Ø125	Положительная геометрия. Экономичность в эксплуатации за счет применения СМП с 8\$мью режущими гранями	●					E47 E48
		AFO(M)5000			Ø80~Ø315							
	Power Buster	PBAC(M)5000		45°	Ø80~Ø315	Высокая эффективность применения при черновой обработке. Позволяет работать на высокой подаче и глубине резания	●					E52
		PBZC(M)5000		80°	Ø80~Ø315							
	Aero Mill	APD(M) A Тип, B Тип		90°	Ø80~Ø315	Эффективное применение на высокоскоростных станках. Алюминиевый сбалансированный корпус (G2,5). Применимы СМП без покрытия и пластины с ПКА	●					E79 E80







Назначение	Серия	Обозначение	Эскиз	Угол в плане	Диаметр фрезы, мм	Общие характеристики	Обработка					Стр.
							Плоскостей	Уступов	Пазов	Контуров	Тангенциальное врезание	
Аero Mill Mini		MAPDS <i>New</i>		90°	Ø40~Ø63	8 режущих кромок СМП, эффективная обработка углеродистых и нержавеющей сталей, чугунов, алюминиевых сплавов	●					E81
		MAPD <i>New</i>		90°	Ø32~Ø40		●					E81
Фрезерование плоскостей	Rich Mill	RM8AC(M)4000 RMH8AC(M)4000 <i>New</i>		45°	Ø50~Ø400	8 режущих кромок СМП, эффективная обработка углеродистых и нержавеющей сталей, чугунов, алюминиевых сплавов	●					E60 E61 E62 E63
				Ø80~Ø400								
		RM8EC(M)4000 RMH8EC(M)4000 <i>New</i>		75°	Ø50~Ø400	Эффективное применение на станках малой мощности. Применимы СМП без покрытия и пластины с ПКА. Корпус сбалансирован G2,5	●					E64 E65 E66 E67
		Ø80~Ø400										
		RM8QC(M)4000 RMH8QC(M)4000		88°	Ø63~Ø200	8 режущих кромок СМП. Низкие силы резания. Высокоэффективная обработка чугуна	●					E68 E69
		RM16AC(M) 6000/8000		45°	Ø63~Ø400	16 режущих кромок СМП. Высокое качество чистовой обработки за счет применения СМП типа «Wiper». Надежное крепление СМП	●					E70 E71
		RMT8A(M) 4000/5000		45°	Ø80~Ø315	Простота замены СМП.	●					E72 E73
		RMT8E(M) 4000/5000		75°	Ø80~Ø315	Высокая эксплуатационная надежность системы зажима СМП. 8 режущих кромок. Высокое качество чистовой обработки.	●					E74 E75
		RMT8Q(M)		88°	Ø80~Ø315		●					E76















Назначение	Серия	Обозначение	Эскиз	Угол в плане	Диаметр фрезы, мм	Общие характеристики	Обработка					Стр.
							Плоскостей	Уступов	Пазов	Контуров	Тангенциальное врезание	
Фрезерование пресс форм	Alpha Mill	AMC(M) 1000S/1500S/ 2000S		90°	Ø32~Ø100	Трехступенчатый стружколом способствует стабильному отводу стружки. Высокая эффективность при фрезеровании уступов пазов и плоскостей	•	•	•	•	•	E88 ~E89
		AMC(M) 3000S/3000S-K/ 4000S		90°	Ø40~Ø200		•	•	•	•	•	E91 ~E93
		AMC(M) 1000SE 2000SE 3000SE		75°	Ø40~Ø100		•					E94 E95
		AMC(M) 2000M 3000M 4000M		90°	Ø50~Ø125		•	•	•	•	•	E96 E97 E98
	Future Mill	FMAC(M)3000		45°	Ø50~Ø125	Стабильный отвод стружки	•					E142 E143
					Ø50~Ø200							
		FMAC(M)3000A		45°	Ø63~Ø125	Высокоскоростная обработка материалов с высоким коэффициентом обрабатываемости	•					E144 E145
					Ø63~Ø315							
		FMPC(M)3000		90°	Ø50~Ø100	4 режущих кромки СМП. Универсальность при обработке различных поверхностей.	•	•	•			E148 E149
					Ø63~Ø125							
		FMPC(M)3000A		90°	Ø63~Ø100	Значительная эффективность при высокоскоростной обработке. Возможность применения на станках с малой мощностью за счет легкого алюминиевого корпуса фрезы.	•	•	•			E150 E151
					Ø63~Ø315							
		FMRC(M)3000			Ø40~Ø100	4\$8 режущих кромок СМП.	•					E154 E155
					Ø50~Ø125							
FMRC(M)5000			Ø50~Ø125	Надежное крепление СМП за счет специальной геометрии опорной поверхности.	•					E156 E157		
			Ø63~Ø160									













Назначение	Серия	Обозначение	Эскиз	Угол в плане	Диаметр фрезы, мм	Общие характеристики	Обработка					Стр.						
							Плоскостей	Уступов	Пазов	Контуров	Тангенциальное врезание							
Фрезерование пресс форм	HRM	HRMC(M)13		15°	Ø50~Ø80	Увеличение надежности фиксации СМП за счет применения дополнительного верхнего прижима. 3 режущих кромки СМП. Низкие силы резания. Повышение производительности за счет возможности применения высоких подач.	●	●	●	●	●	E181						
		HRMC(M)15			Ø63~Ø160													
	HRMD	HRMDC(M)09		14°	Ø40~Ø100	Двухсторонняя СМП с 6 режущими кромками. Возможность применения высоких подач. Высокая надежность крепления СМП.	●	●	●	●	●	E171 ~ E173						
		HRMDC(M)13			Ø50~Ø125													
		HRMDC(M)16 <i>New</i>			Ø80~Ø315													
	Концевые сборные фрезы с хвостовиком BT/HSK	BT30/40/50 HSK63		90°	Ø10~Ø50	Обеспечение высокой точности установки фрезы за счет цельного исполнения фрезы и хвостовика под шпиндельный конус BT/HSK. Внутренний подвод СОЖ обеспечивает стабильный отвод стружки из зоны резания. Возможность применения высоких подач и глубин резания.	●	●	●	●	●	E117 ~ E118						
							BT30/40/50 HSK63/100		90°	Ø16~Ø100	Оправки под модульные головки серии Alpha\$Mill, Rich Mill, FMR, Laser Mill, HRM(D), Pro\$A, Pro\$X. Присоединительная резьба M6\$M16	●	●	●	●	●	E122 ~ E124	
		BT30/40/50-MAT HSK63/100-MAT		90°	Ø12~Ø40	Сменная торцевая рабочая часть. Экономичность применения.						●	●	●	●	●	E126 ~ E129	
							BT50 HAT4000		90°	Ø50~Ø80	Крутая спираль и большая глубина резания. Высокая перпендикулярность. Низкие усилия резания.	●	●	●	●	●	E130 ~ E131	
		Pro-L Mill	PALC(M) <i>New</i>		90°	Ø63						Надежность закрепления СМП. Препятствие наростообразованию за счет специальной геометрии передней поверхности СМП.	●	●	●	●	●	E125
							Pro-A Mill	PAC(M) 4000		90°	Ø40~Ø100		Надежность закрепления СМП. Возможность применения винтового и тангенциального врезания.	●	●	●	●	●
	Pro-X Mill	PAXC(M)5000 PAXC(M)6000		90°	Ø40~Ø125 Ø50~Ø125	Надежность закрепления СМП. Препятствие наростообразованию за счет специальной геометрии передней поверхности СМП.						●		●	●	●	●	E224
												Pro-X Mill		PAXC(M)5000 PAXC(M)6000		90°	Ø40~Ø125 Ø50~Ø125	Надежность закрепления СМП. Возможность применения винтового и тангенциального врезания.







Назначение	Серия	Обозначение	Эскиз	Угол в плане	Диаметр фрезы, мм	Общие характеристики	Обработка					Стр.
							Плоскостей	Уступов	Пазов	Контуров	Тангенциальное врезание	
Высокопроизводительная обработка чугуна. Высокопроизводительные торцевые сборные фрезы	Торцевые высокопроизводительные фрезы для обработки чугуна	ANH 4000/5000		45°	Ø100~Ø450	Возможность применения силового резания. Стабильный отвод стружки.	●					E259 E260
		CDH 4000/5000		65°	Ø100~Ø450	Положительный осевой и радиальный передний угол. Снижение сил резания.	●					E261 E262
		DEH 5000		60°	Ø100~Ø450	Высокоэффективная обработка алюминия и алюминиевых сплавов.	●					E263
		DPH 5000		60°	Ø100~Ø450	Экономичность применение. Использование шестигранных СМП.	●					E264
		PNH 4000/5000		90°	Ø125~Ø450	Обеспечение высокого качества обработанной поверхности за счет применения СМП типа «Wiper». Отрицательная геометрия.	●					E265
		PPH 4000		90°	Ø125~Ø450	4 режущих кромки СМП. Обеспечение высокого качества обработанной поверхности за счет применения СМП типа «Wiper».	●					E266
	Shave Mill	SVM(M)4000		90°	Ø80~Ø315	Эксклюзивное регулировочное устройство легко выставляет биение режущих кромок	●					E267
	Shave Mill Ultra	SVUM6000		90°	Ø80~Ø315	Высокая жесткость крепления СМП.	●					E268
		SVUM6000-B		90°	Ø80~Ø315	Повышение прочности режущих кромок за счет тангенциального расположения СМП.	●					E269
	Фрезерование торцов, пазов, габаритных размеров и т.д.	Радиальный тип	Трехсторонняя фреза	TAFCP		-	Ø100~Ø315		●	●		
TAFCB					-	Ø100~Ø315	Возможность регулирования высоты режущей кромки.	●	●	●		
Двухсторонняя фреза		TAHCP		-	Ø100~Ø315	Усиленная режущая кромка. Высокая эффективность применения при черновой и получистовой обработке.	●	●				E238
		TAHCB		-	Ø100~Ø315		●	●	●			E238



Назначение	Серия	Обозначение	Эскиз	Угол в плане	Диаметр фрезы, мм	Общие характеристики	Обработка					Стр.
							Плоскостей	Уступов	Пазов	Контуров	Тангенциальное врезание	
Фрезерование торцов, пазов, габаритных размеров и т.д.	Тангенциальный тип	Трехсторонняя фреза	RAFCP		-	Ø100~Ø315			●	●		E239
		RAFCB		-	Ø100~Ø315	Возможность регулирования высоты режущей кромки.	●	●	●		E239	
	Двухсторонняя фреза	RAHCP		-	Ø100~Ø315	Высокая эффективность применения при чистовой и получистовой обработке. Стабильный отвод стружки за счет трехступенчатого стружклома.			●	●		E240
		RAHCB		-	Ø100~Ø315		●	●	●		E240	
Прорезание пазов, отрезка	Трехсторонняя фреза	FC		-	Ø80~Ø315	Стабильный отвод стружки. Снижение сил резания.			●	●		E241
		Двухсторонняя фреза	HC		-	Ø100~Ø315	Стабильный отвод стружки. Снижение сил резания.			●	●	
	-	SPP(M)		-	Ø80~Ø200	Снижение себестоимости обработки за счет применения СМП с 5-тью режущими кромками. Возможность фрезерования глубоких пазов.				●		E243
		SPB(M)		-	Ø80~Ø200	Возможность фрезерования глубоких пазов.				●		E244
		SPS		-	Ø50~Ø200	Обработка глубоких и узких канавок.				●		E245
	Wind Mill	WFSB(M) <i>New</i>		-	Ø80~Ø250	Радиус закругления режущей кромки R увеличивает срок службы пластин.		●	●	●		E268
		WFSP(M) <i>New</i>		-	Ø80~Ø250	Широкое применение с различной шириной и радиусами R при вершине.			●	●		E269



Назначение	Серия	Обозначение	Эскиз	Угол в плане	Диаметр фрезы, мм	Общие характеристики	Обработка					Стр.
							Плоскостей	Уступов	Пазов	Контуров	Тангенциальное врезание	
Фрезерование плоскостей	Turbo Mill	ADS 4000/5000		45°	Ø50~Ø63	Снижение вибраций за счет применного шага зубьев	●					E44 E45
		PES 2000/3000/4000		90°	Ø20~Ø63	Снижение сил резания за счет положительной геометрии СМП	●		●			E46
Фрезерование пресс форм	Alpha Mill	AMS 1000S/1500S 2000S/3000S 3000S-K/4000S		90°	Ø10~Ø63	Сочетание 3 мерной кривой дизайн и высокую переднего угла помогает эффективно удаление стружки с низкой силы резания.	●		●	●		E99 ~E106
		AMS 1000SE/2000SE 3000SE		75°	Ø25~Ø63		Внутренняя система охлаждения Различные диапазон вставками может обеспечить расширен выбор	●				
		AMS 1000M/1500M 2000M/4000M		90°	Ø16~Ø50	Высокая глубина и высокая корма может быть доступны во время работы.	●		●	●		E109 E110
		AMS 1000MH/1500MH 2000MH/3000MH		90°	Ø14~Ø40		●		●	●		E111
	Future Mill	FMAS3000		45°	Ø25~Ø63	Высокая эффективность применения на прицизионных станках. Стабильный отвод стружки.	●					E146 E147
		FMAS4000			Ø50~Ø63							
		FMPS3000		90°	Ø25~Ø63	4 режущих кромки СМП. Усиленная режущая кромка. Низкие силы резания.	●					E152 E153
		FMPS4000			Ø40~Ø63							
		FMRS 1000/1500/2000 2500/3000/4000 5000/6000		-	Ø8~Ø63	Двойное зажим	●		●	●		E158 ~163
	HRM	HRMS 08/10/13/15		15°	Ø20~Ø63	Возможность применения высоких подач за счет высокой эксплуатационной надежности закрепления СМП. Использование комбинированного прижима СМП. Низкие силы резания.	●	●	●	●	●	E182 E183 E184
HRMD	HRMDS 06 09/13		14°	Ø16~Ø63	Двухсторонняя геометрия СМП с 6-тью режущими кромками. Возможность применения высоких подач	●		●		●	E175 ~178	
Tank Mill	THE		90°	Ø25~Ø50	Специальная геометрия стружечной канавки обеспечивает минимальное ослабление корпуса фрезы и стабильный отвод стружки из зоны резания. Усиленные режущие кромки СМП.	●					E186	
Laser Mill	LBE□□ LRE□□		-	Ø8~Ø32	Специальная геометрия стружечной канавки обеспечивает стабильный отвод стружки из зоны резания. Усиленные режущие кромки СМП.	●		●			E195 ~198	



Концевые сборные фрезы

Назначение	Серия	Обозначение	Эскиз	Угол в плане	Диаметр фрезы, мм	Общие характеристики	Обработка					Стр.					
							Плоскостей	Уступов	Пазов	Контуров	Тангенциальное врезание						
Фрезерование пресс форм	Laser Mill	LBE□□-C LRE□□-C		-	Ø8~Ø32	Высокоэффективная обработка пресс-форм. Прочный корпус фрезы обеспечивает высокую точность чистовых операций с применением системы охлаждения MQL.	●	●	●			E195 E197					
	Mach Mill	BFE		-	Ø16~Ø32	Высокоэффективная обработка пресс-форм. Прочный корпус фрезы обеспечивает высокую точность чистовых операций с применением системы охлаждения MQL.	●	●	●	●			E199				
		GBE		-	Ø16~Ø50	Специальная геометрия режущей кромки способствует снижению сил резания. Гарантируется безопасность применения фрезы при высокой частоте вращения.	●	●	●	●			E200				
		BRE		-	Ø20~Ø63	Специальная геометрия стружечных канавок и режущих кромок способствует стабильному отводу стружки и исключает вероятность пакетирования.	●	●	●	●			E202				
	O-Фиксатор Cutter	ORC <i>New</i>		90°	Ø11~Ø46	Высокая эффективность применения для фрезерования канавок под полимерные уплотнительные кольца, в место традиционно применяемых цельных быстрорежущих фрез	-	-	-	-	-		E204				
	Chamfer tool	CE		75°	Ø25~Ø30	Широкая универсальность при обработке фасок.	-	-	-	-	-	-	E208				
				60°	Ø25~Ø35												
				45°	Ø7~Ø39												
		CCT <i>New</i>		30°	Ø5~Ø35	Возможность обработки фасок желаемой длины и геометрии.	-	-	-	-	-	-	E209				
				45°	Ø5~Ø48												
				60°	Ø5~Ø57												
	CET <i>New</i>		45°	~Ø28	Высокая эффективность при центровании отверстий, обработки канавок и фасок.	-	-	-	-	-	-	E210					
			30°	Ø3~Ø16									Центр кольца, зенкерования, снятия фаски	-	-	-	-
45°																	
60°	Ø4~Ø16	зенкерования, снятия фаски, Уступы	-	-	-	-	-	E211									
T-Cutter	TFE		90°	Ø21~Ø50	Высокоэффективная обработка пазов.	●	●	●	●	●		E213					
Обработка алюминия	Pro-L Mill	PALS-HR <i>New</i>		90°	Ø32~Ø63	Эксклюзивное регулировочное устройство легко выставляет биение режущих кромок. Высокая перпендикулярность. Низкие усилия резания.	●	●	●	●	●	E218					
		PALS-HM <i>New</i>			Ø63												
	Pro-A Mill	PAS 2000/4000		90°	Ø12~Ø42	Высокая эксплуатационная надежность закрепления СМП. Повышенная жесткость корпуса. Высокая эффективность при использовании круговой и прямоугольной интерполяции.	●	●	●	●	●	E225					
					Ø32~Ø40												
Pro-X Mill	PAXS 5000/6000		90°	Ø20~Ø40 Ø25~Ø40	Препятствие наростообразованию за счет специальной геометрии передней поверхности СМП.	●	●	●	●	●		E229					
Фрезерование резьбы	-	TM		-	Ø32~Ø50	Высокоэффективное нарезание внешней и внутренней резьбы.	●					D49					



FMRM Тип

 E164, 165



LBE-MHD Тип

 E198



PAM Тип

 E226



AMM Тип

 E112, 113, 114



HRMM Тип

 E185



HRMDM Тип

 E179, 180



PAXM Тип

 E231



**Стальной
хвостовик**

 E233



**Твердосплавный
хвостовик**

 E234



Оправка BT

 E130



Оправка HSK

 E131



ADN(M) 4000



Рис. 1



Рис. 2

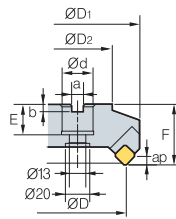

Рис. 3

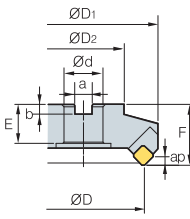

Рис. 4

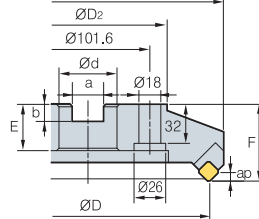

• AR : 15°
• RR : -4°

(мм)

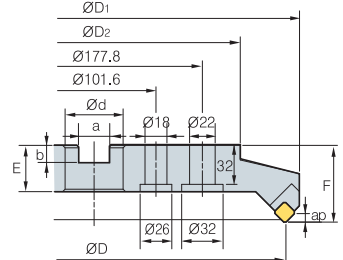
Обозначение		ØD	ØD1	ØD2	Ød	a	b	E	F	ap		Рис.
ADN(M) 4080R/L	4	80	105	57	25.4(27)	9.5(12.4)	6(7)	25(22)	50	6	1.9	1
4100R/L	5	100	125	67	31.75(32)	12.7(14.4)	8(8)	32(28)	50	6	2.5	2
4125R/L	6	125	149	87	38.1(40)	15.9(16.4)	10(9)	38(30)	63	6	4.3	2
4160R/L	8	160	183	107	50.8(40)	19.0(16.4)	11(9)	38(30)	63	6	6.4	2
4200R/L	10	200	223	130	47.625(60)	25.4(25.7)	14(14)	38(38)	63	6	8.7	3
4250R/L	12	250	273	180	47.625(60)	25.4(25.7)	14(14)	38(38)	63	6	14.0	3
4315R/L	14	315	338	240	47.625(60)	25.4(25.7)	14(14)	38(38)	63	6	21.0	4

• () Метрическая система

Применяемые СМП

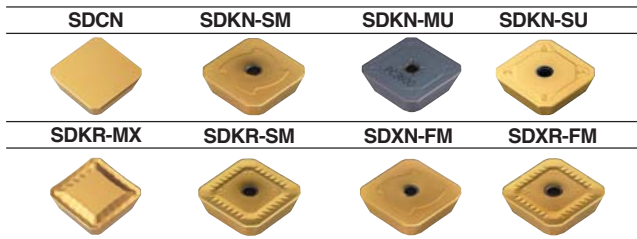

Обозначение	Тв. сплав с покрытием				Кермет	Тв. сплав				Стр.						
	NCM325	NCM335	NC5330	PC3500		PC3600	PC5300	PC3545	PC6510		PC215K	PD2000	CN20	H01	G10	ST30A
SDCN 42M																
42M-G																
42MT																
42MT-RH																
42MT-S20																
1203AEEN																
1203AEEN-RH																
1203AESN																
1203AESN-RH																
SDKN 1203AESN-SM																
1203AEEN-SM																
1203AESN-MU																
1203AESN-SU																
SDKR 1203AESN-MX																
1203AETN-MX																
1203AEEN-MX																
1203AESN-SM																
SDXN 1203AESN-FM																
1203AEEN-FM																
SDXR 1203AESN-FM																

Применяемые оправки

Обозначение	Оправка с хвостиком NT	Оправка с хвостиком BT	
		ADN	ADNM
ADN(M)4080R/L	NT*□□(M/U)-FMA25.4-25	BT**□□-FMA25.4 -□□	FMC27
4100R/L	NT*□□(M/U)-FMA31.75 - □□	BT**□□-FMA31.75 -□□	FMC32
4125R/L	NT*□□(M/U)-FMA38.1 - □□	BT**□□-FMA38.1 -□□	FMB40
4160R/L	NT*□□(M/U)-FMA50.8 - □□	BT**□□-FMA50.8 -□□	FMB40
4200R/L	NT*□□(M/U)-FMA47.625-25, KCP-8***	BT**□□-FMA47.625-□□	FMB60
4250R/L	NT*□□(M/U)-FMA47.625-25, KCP-8***	BT**□□-FMA47.625-□□	FMB60
4315R/L	KCP-8*** (Без центрального отверстия)		

*□□-NT(No) **□□-BT(No) ***Для больших диаметров

Рекомендации по выбору режимов резания и марки сплава

Обрабатываемые материалы	Режимы резания		Марка сплава
	V(м/мин)	Sz(мм/зуб)	
P	150 ~ 300	0.05 ~ 0.15	NCM325
	120 ~ 230	0.05 ~ 0.20	PC3500
	100 ~ 200	0.05 ~ 0.20	ST30A
M	50 ~ 200	0.05 ~ 0.20	PC9530
	50 ~ 120	0.05 ~ 0.20	ST30A
K	150 ~ 250	0.05 ~ 0.30	PC6510
	100 ~ 200	0.05 ~ 0.30	G10

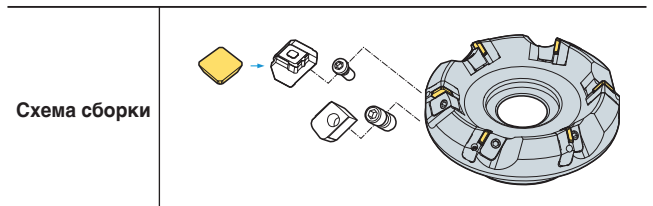

Комплектующие

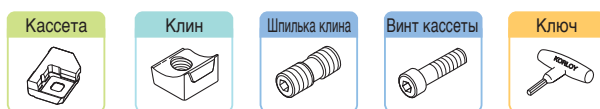

LADN4R/L WEPN4R/L DHA0821F LTX0514 HW40



ADN(M)5000+

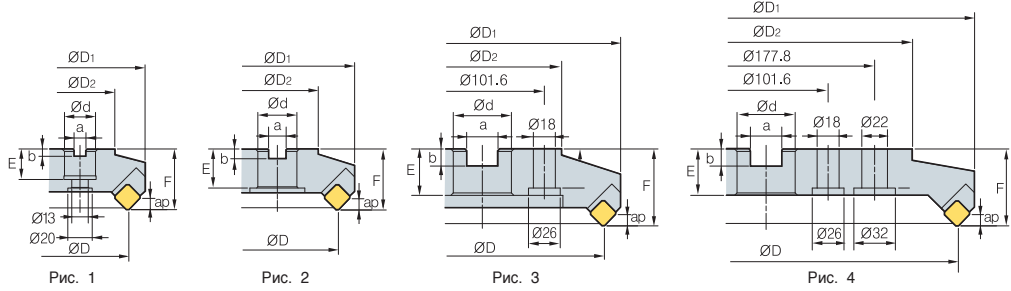

AA
45°
• AR : 15°
• RR : -4°

(мм)

Обозначение		øD	øD1	øD2	ød	a	b	E	F	ap		Рис.
ADN(M) 5080R/L+	4	80	107	57	25.4(27)	9.5(12.4)	6(7)	25(22)	50	8	2.0	1
5100R/L+	5	100	126	67	31.75(32)	12.7(14.4)	8(8)	32(28)	50	8	2.7	2
5125R/L+	6	125	150	87	38.1(40)	15.9(16.4)	10(9)	38(30)	63	8	4.3	2
5160R/L+	8	160	185	107	50.8(40)	19.0(16.4)	11(9)	38(30)	63	8	6.5	2
5200R/L+	10	200	225	130	47.625(60)	25.4(25.7)	14(14)	38(38)	63	8	9.1	3
5250R/L+	12	250	275	180	47.625(60)	25.4(25.7)	14(14)	38(38)	63	8	14.5	3
5315R/L+	14	315	340	240	47.625(60)	25.4(25.7)	14(14)	38(38)	63	8	21.0	4

• () Метрическая система

Применяемые СМП

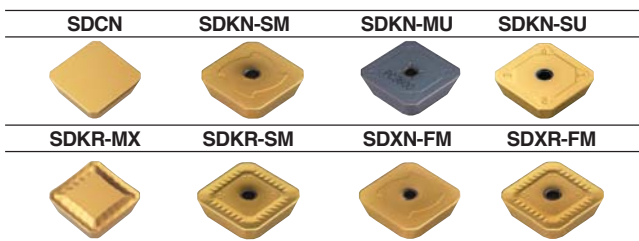

Обозначение	Тв. сплав с покрытием										Кермет	Тв. сплав			Стр.				
	NCM325	NCM335	NC5330	PC3500	PC3800	PC5900	PC3545	PC9530	PC6510	PC215K		PD2000	CN2000	CN20		CN30	HP1	G10	ST30A
SDCN 53M																			
53M-G																			
53MT	•	•										•	•					•	
53MT-RH				•															
53MT-S20																			
1504AEEN																			
1504AEEN-RH					•														
1504AESN																			
1504AESN-RH																			
SDKN 1504AESN-SM																			
1504AEEN-SM																			
1504AESN-MU					•														
1504AESN-SU					•	•													
SDKR 1504AESN-MX	•																		
1504AETN-MX																			
1504AEN-MX	•																		
1504AESN-SM																			
SDXN 1504AESN-FM																			
1504AEEN-FM																			
SDXR 1504AESN-FM																			

Применяемые оправки

Обозначение	Оправка с хвостовиком NT	Оправка с хвостовиком BT	
		ADN	ADNM
ADN(M)5080R/L	NT*□□(M/U)-FMA25.4-25	BT**□□-FMA25.4-□□	FMC27
5100R/L	NT*□□(M/U)-FMA31.75-□□	BT**□□-FMA31.75-□□	FMC32
5125R/L	NT*□□(M/U)-FMA38.1-□□	BT**□□-FMA38.1-□□	FMB40
5160R/L	NT*□□(M/U)-FMA50.8-□□	BT**□□-FMA50.8-□□	FMB40
5200R/L	NT*□□(M/U)-FMA47.625-25, KCP-8***	BT**□□-FMA47.625-□□	FMB60
5250R/L	NT*□□(M/U)-FMA47.625-25, KCP-8***	BT**□□-FMA47.625-□□	FMB60
5315R/L	KCP-8*** (Без центрального отверстия)		

*□□-NT(No) **□□-BT(No) ***Для больших диаметров

Рекомендации по выбору режимов резания и марки сплава

Обрабатываемые материалы	Режимы резания		Марка сплава
	V(м/мин)	Sz(мм/зуб)	
P	150 ~ 300	0.05 ~ 0.15	NCM325 PC3500 ST30A
	120 ~ 230	0.05 ~ 0.20	
	100 ~ 200	0.05 ~ 0.20	
M	50 ~ 200	0.05 ~ 0.20	PC9530 ST30A
	50 ~ 120	0.05 ~ 0.20	
K	150 ~ 250	0.05 ~ 0.30	PC6510 G10
	100 ~ 200	0.05 ~ 0.30	

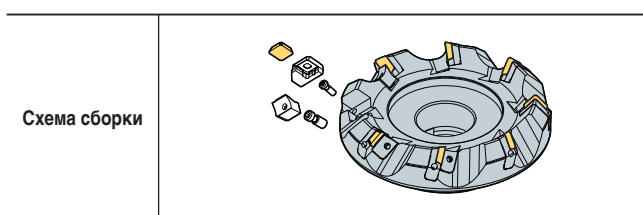

Комплектующие

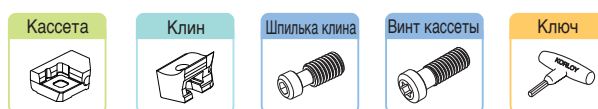

LADN5R/L WHPS5R/L WHX0817 LTX0514 HW40

AE(M) 4000



Рис. 1



Рис. 2

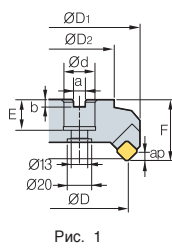

Рис. 3

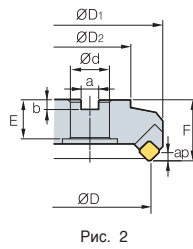

Рис. 4

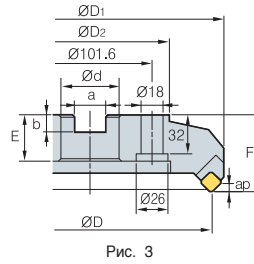

AA
45°
• AR : 20°
• RR : -3°

Обозначение		ØD	ØD1	ØD2	Ød	a	b	E	F	ap		Рис.
AE(M)												
4080R/L	4	80	103	60	25.4(27)	9.5(12.4)	6(7)	25(22)	50	5.5	1.7	1
4100R/L	5	100	122	80	31.75(32)	12.7(14.4)	8(8)	32(28)	50	5.5	2.9	2
4125R/L	6	125	146	100	38.1(40)	15.9(16.4)	10(9)	38(30)	63	5.5	4.4	2
4160R/L	8	160	181	120	50.8(40)	19.0(16.4)	11(9)	38(30)	63	5.5	6.1	2
4200R/L	10	200	220	130	47.625(60)	25.4(25.7)	13.5(14)	38(38)	63	5.5	8.9	3
4250R/L	12	250	270	180	47.625(60)	25.4(25.7)	13.5(14)	38(38)	63	5.5	15.7	3
4315R/L	15	315	335	240	47.625(60)	25.4(25.7)	13.5(14)	38(38)	63	5.5	25.1	4

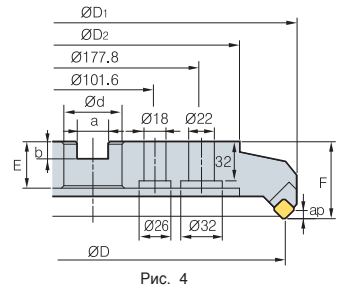
(мм)

• () Метрическая система

Применяемые СМП

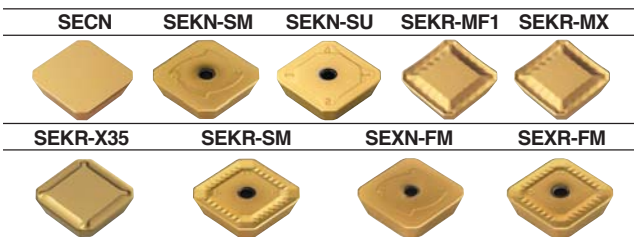

Обозначение	Тв. сплав с покрытием								Кермет		Тв. сплав		Стр.					
	NCM825	NCM835	NC5330	PC3500	PC3600	PC3900	PC3945	PC9530	PC6510	PC215K	PD2000	CN2000		CN20	CN80	H01	G10	ST30A
SECN 1203AFFN																		
1203AFTN																		
1203AFEN																		
1203AFSN	•	•																
1203AFEN-RH																		
1203AFSN-RH																		
1203AFTN-S20																		
SEKN 1203AFSN-SM																		
1203AFEN-SM																		
1203AFSN-SU																		
SEKR 1203AFSN-MF1																		
1203AFSN-MX	•	•																
1203AFSN-X35																		
1203AFFN-X35																		
1203AFSN-SM																		
SEKN 1203AFSN-FM																		
1203AFEN-FM																		
SEXR 1203AFSN-FM																		

Применяемые оправки

Обозначение	Оправка с хвостовиком NT	Оправка с хвостовиком BT	
		AE	AEM
AE(M)4080R/L	NT*□□ (M/U)-FMA25.4-25	BT**□□ -FMA25.4 - □□	FMC27
4100R/L	NT*□□ (M/U)-FMA31.75 - □□	BT**□□ -FMA31.75 - □□	FMC32
4125R/L	NT*□□ (M/U)-FMA38.1 - □□	BT**□□ -FMA38.1 - □□	FMB40
4160R/L	NT*□□ (M/U)-FMA50.8 - □□	BT**□□ -FMA50.8 - □□	FMB40
4200R/L	NT*□□ (M/U)-FMA47.625-25, KCP-8***	BT**□□ -FMA47.625 - □□	FMB60
4250R/L	NT*□□ (M/U)-FMA47.625-25, KCP-8***	BT**□□ -FMA47.625 - □□	FMB60
4315R/L	KCP-8*** (Без центрального отверстия)		

*□□ -NT(No) **□□ -BT(No) ***Для больших диаметров

Рекомендации по выбору режимов резания и марки сплава

Обрабатываемые материалы	Режимы резания		Марка сплава
	V(м/мин)	Sz(мм/зуб)	
P	150 ~ 300	0.05 ~ 0.15	NCM325
	120 ~ 230	0.05 ~ 0.20	PC3500
	100 ~ 200	0.05 ~ 0.20	ST30A
M	50 ~ 200	0.05 ~ 0.20	PC9530
	50 ~ 120	0.05 ~ 0.20	ST30A
K	150 ~ 250	0.05 ~ 0.30	PC6510
	100 ~ 200	0.05 ~ 0.30	G10

Схема сборки

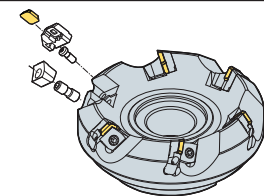

Комплектующие

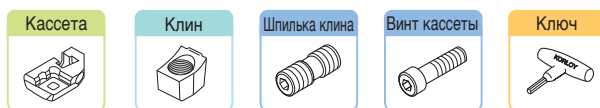

LAE4R/L WAE4R/L DHA0821F LTX0512 HW40

Применяемые СМП E15, E16

Присоединительные размеры смотреть на стр. E270~E272

• : Наличие на складе

AE(M)5000



Рис. 1



Рис. 2

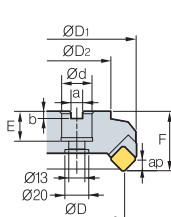

Рис. 3

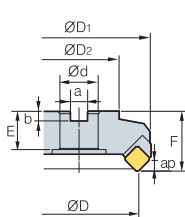

Рис. 4

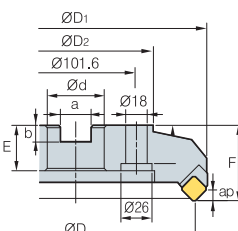

AA
45°
• AR : 20°
• RR : -3°

Обозначение		⊙	øD	øD ₁	øD ₂	ød	a	b	E	F	ap	⊙ _{kg}	Рис.
AE(M)	5080R/L	4	80	103	60	25.4(27)	9.5(12.4)	6(7)	25(22)	50	7.5	1.7	1
	5100R/L	5	100	122	80	31.75(32)	12.7(14.4)	8(8)	32(28)	50	7.5	2.9	2
	5125R/L	6	125	146	100	38.1(40)	15.9(16.4)	10(9)	38(30)	63	7.5	4.4	2
	5160R/L	8	160	181	120	50.8(40)	19.0(16.4)	11(9)	38(30)	63	7.5	6.1	2
	5200R/L	10	200	220	130	47.625(60)	25.4(25.7)	13.5(14)	38(38)	63	7.5	8.9	3
	5250R/L	12	250	270	180	47.625(60)	25.4(25.7)	13.5(14)	38(38)	63	7.5	15.7	3
	5315R/L	15	315	335	240	47.625(60)	25.4(25.7)	13.5(14)	38(38)	63	7.5	25.1	4

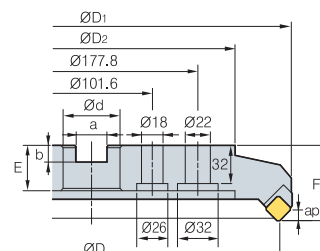
(мм)

• () Метрическая система

Применяемые СМП

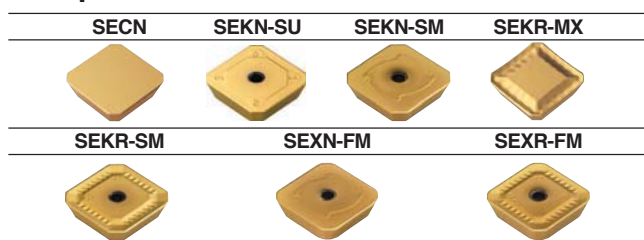

Обозначение	Тв. сплав с покрытием				Кермет			Тв. сплав		Стр.							
	NCM325	NCM335	PC3500	PC3600	PC3545	PC9530	PC6510	PC215K	PD2000		CN2000	CN30	H01	G10	ST30A		
SECN 1504AFFN																	
1504AFTN																	
1504AFEN																	
1504AFSN	•	•															
1504AFEN-RH																	
1504AFSN-RH																	
1504AFTN-S20																	
SEKN 1504AFSN-SM																	
1504AFEN-SM																	
1504AFSN-SU																	
SEKR 1504AFSN-MX	•	•															
1504AFSN-SM																	
SEXN 1504AFSN-FM																	
1504AFEN-FM																	
SEXR 1504AFSN-FM																	

Применяемые оправки

Обозначение	Оправка с хвостовиком NT	Оправка с хвостовиком BT	
		AE	AEM
AE(M)5080R/L	NT*□□(M/U)-FMA25.4-25	BT**□□-FMA25.4-□□	FMC27
5100R/L	NT*□□(M/U)-FMA31.75-□□	BT**□□-FMA31.75-□□	FMC32
5125R/L	NT*□□(M/U)-FMA38.1-□□	BT**□□-FMA38.1-□□	FMB40
5160R/L	NT*□□(M/U)-FMA50.8-□□	BT**□□-FMA50.8-□□	FMB40
5200R/L	NT*□□(M/U)-FMA47.625-25, KCP-8***	BT**□□-FMA47.625-□□	FMB60
5250R/L	NT*□□(M/U)-FMA47.625-25, KCP-8***	BT**□□-FMA47.625-□□	FMB60
5315R/L	KCP-8*** (Без центрального отверстия)		

*□□-NT(No) **□□-BT(No) ***Для больших диаметров

Рекомендации по выбору режимов резания и марки сплава

Обрабатываемые материалы	Режимы резания		Марка сплава
	V(м/мин)	Sz(мм/зуб)	
P	150 ~ 300	0.05 ~ 0.15	NCM325
	120 ~ 230	0.05 ~ 0.20	PC3500
	100 ~ 200	0.05 ~ 0.20	ST30A
M	50 ~ 200	0.05 ~ 0.20	PC9530
	50 ~ 120	0.05 ~ 0.20	ST30A
K	150 ~ 250	0.05 ~ 0.30	PC6510
	100 ~ 200	0.05 ~ 0.30	G10

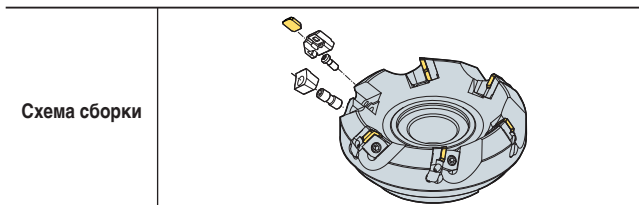

Комплектующие



LAE5R/L WAE5R/L DHA0821F LTX0512 HW40

EF(M)4000

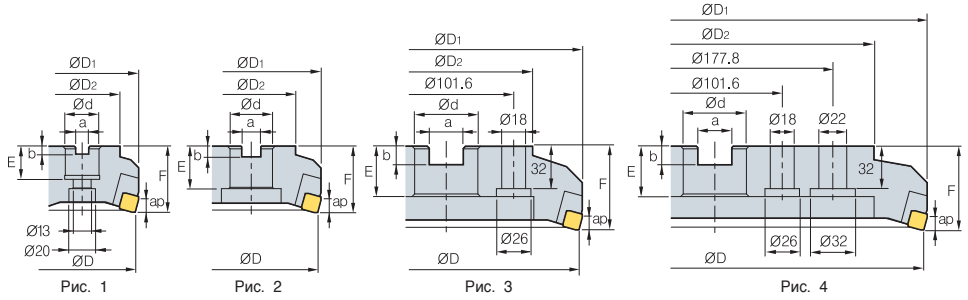

Обозначение		ØD	ØD ₁	ØD ₂	Ød	a	b	E	F	ap		Рис.
EF(M)												
4080R/L	4	80	89	57	25.4(27)	9.5(12.4)	6(7)	25(22)	50	8.0	1.5	1
4100R/L	5	100	108	70	31.75(32)	12.7(14.4)	8(8)	32(28)	50	8.0	2.1	2
4125R/L	6	125	133	87	38.1(40)	15.9(16.4)	10(9)	38(30)	63	8.0	3.8	2
4160R/L	8	160	168	107	50.8(40)	19.0(16.4)	11(9)	38(30)	63	8.0	5.5	2
4200R/L	10	200	208	130	47.625(60)	25.4(25.7)	13.5(14)	38(38)	63	8.0	8.2	3
4250R/L	12	250	257	180	47.625(60)	25.4(25.7)	13.5(14)	38(38)	63	8.0	13.4	3
4315R/L	16	315	322	240	47.625(60)	25.4(25.7)	13.5(14)	38(38)	63	8.0	21.2	4

() Метрическая система

Применяемые СМП

Обозначение	Тв. сплав с покрытием						Кермет	Тв. сплав	Стр.
	NCM325	NCM335	NC5330	PC3500	PC3530	PC3545			
SFCN 1203EFR									E17

Применяемые оправки

Обозначение	Оправка с хвостиком NT	Оправка с хвостиком BT	
		EF	EFM
EF(M)4080R/L	NT*□□(M/U)-FMA25.4-25-□□	BT**□□-FMA25.4-□□	FMC27
4100R/L	NT*□□(M/U)-FMA31.75-□□	BT**□□-FMA31.75-□□	FMC32
4125R/L	NT*□□(M/U)-FMA38.1-□□	BT**□□-FMA38.1-□□	FMB40
4160R/L	NT*□□(M/U)-FMA50.8-□□	BT**□□-FMA50.8-□□	FMB40
4200R/L	NT*□□(M/U)-FMA47.625-25, KCP-8***	BT**□□-FMA47.625-□□	FMB60
4250R/L	NT*□□(M/U)-FMA47.625-25, KCP-8***	BT**□□-FMA47.625-□□	FMB60
4315R/L	KCP-8*** (Без центрального отверстия)		

*□□-NT(No) **□□-BT(No) ***Для больших диаметров

Рекомендации по выбору режимов резания и марки сплава

Обрабатываемые материалы	Режимы резания		Марка сплава
	V(м/мин)	Sz(мм/зуб)	
К	400 ~ 500	0.05 ~ 0.20	H01

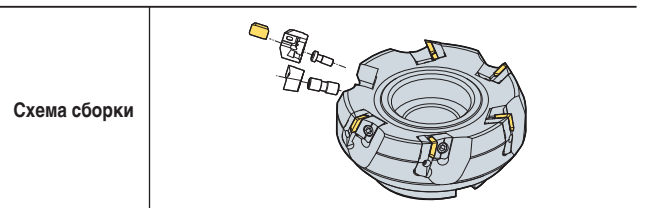

Комплектующие

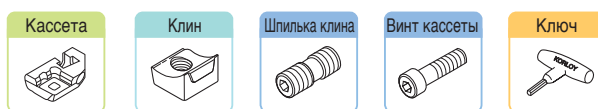

LEF4R/L WEFR/L DHA0821F LTX0512 HW40
LEF4R1*/L1*

*: Ø80 ~ Ø125



EN(M) 4000

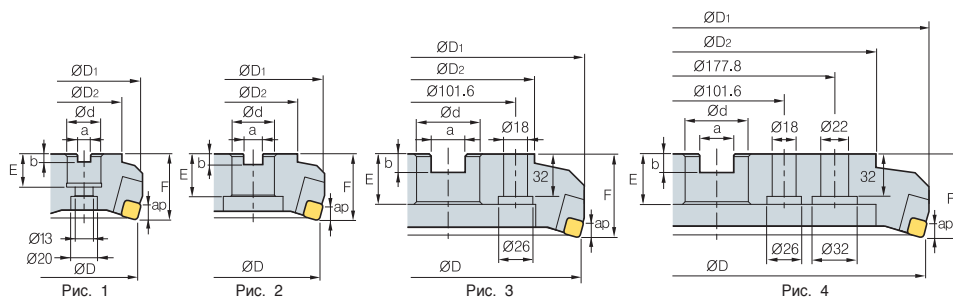

Обозначение		ØD	ØD1	ØD2	Ød	a	b	E	F	ap		Рис.
EN(M) 4080R/L	5	80	87	57	25.4(27)	9.5(12.4)	6(7)	25(22)	50	8.5	1.4	1
4100R/L	6	100	107	67	31.75(32)	12.7(14.4)	8(8)	32(28)	50	8.5	2.1	2
4125R/L	8	125	132	87	38.1(40)	15.9(16.4)	10(9)	38(30)	63	8.5	3.8	2
4160R/L	10	160	167	107	50.8(40)	19.0(16.4)	11(9)	38(30)	63	8.5	5.7	2
4200R/L	12	200	207	130	47.625(60)	25.4(25.7)	13.5(14)	38(38)	63	8.5	8.4	3
4250R/L	16	250	257	180	47.625(60)	25.4(25.7)	13.5(14)	38(38)	63	8.5	13.8	3
4315R/L	20	315	322	240	47.625(60)	25.4(25.7)	13.5(14)	38(38)	63	8.5	21.6	4

() Метрическая система

Применяемые СМП

Обозначение	Тв. сплав с покрытием				Кермет		Тв. сплав			Стр.							
	NCM325	NCM335	NC5330	PC3500	PC3545	PC9530	PC6510	PC215K	PD2000		CN2000	CN20	CN30	H01	G10	ST30A	ST20
SNCN 1204ENN	●													●	●	●	E17
SNKN 1204ENN																	E19

Применяемые оправки

Обозначение	Оправка с хвостовиком NT	Оправка с хвостовиком BT	
		EN	ENM
EN(M) 4080R/L	NT*□□ (M/U)-FMA25.4-25 -□□	BT**□□ -FMA25.4 -□□	FMC27
4100R/L	NT*□□ (M/U)-FMA31.75 -□□	BT**□□ -FMA31.75 -□□	FMC32
4125R/L	NT*□□ (M/U)-FMA38.1 -□□	BT**□□ -FMA38.1 -□□	FMB40
4160R/L	NT*□□ (M/U)-FMA50.8 -□□	BT**□□ -FMA50.8 -□□	FMB40
4200R/L	NT*□□ (M/U)-FMA47.625-25, KCP-8***	BT**□□ -FMA47.625 -□□	FMB60
4250R/L	NT*□□ (M/U)-FMA47.625-25, KCP-8***	BT**□□ -FMA47.625 -□□	FMB60
4315R/L	KCP-8*** (Без центрального отверстия)		

*□□-NT(No) **□□-BT(No) ***Для больших диаметров

Рекомендации по выбору режимов резания и марки сплава

Обрабатываемые материалы	Режимы резания		Марка сплава
	V(м/мин)	Sz(мм/зуб)	
P	150 ~ 300	0.05 ~ 0.15	NCM325 PC3500 ST30A
	120 ~ 230	0.05 ~ 0.20	
	100 ~ 200	0.05 ~ 0.20	
M	50 ~ 200	0.05 ~ 0.20	PC9530 ST30A
	50 ~ 120	0.05 ~ 0.20	
K	150 ~ 250	0.05 ~ 0.30	PC6510 G10
	100 ~ 200	0.05 ~ 0.30	

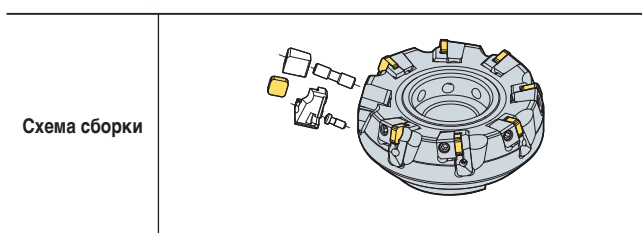

Комплектующие



LEN4R/L WENR/L DHA0830 LTX0512 HW40
WENR1*/L1* DHA0825*

* : Ø80 ~ Ø100



EPN(M)4000

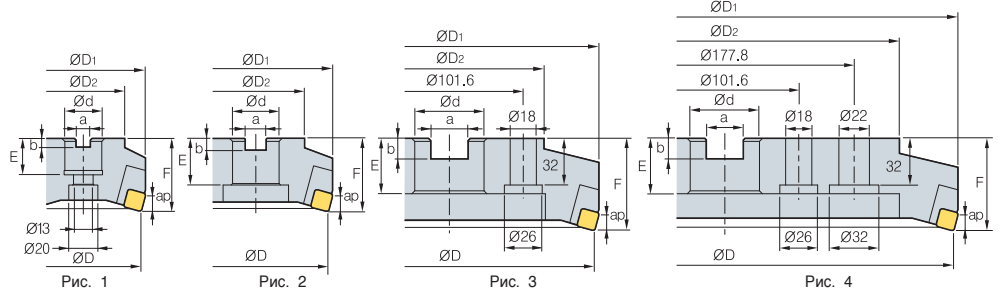

• AR : 7°
• RR : 0°

Обозначение		ØD	ØD ₁	ØD ₂	Ød	a	b	E	F	ap		Рис.
EPN(M) 4080R/L	5	80	86	57	25.4(27)	9.5(12.4)	6(7)	25(22)	50	9	1.4	1
4100R/L	6	100	107	67	31.75(32)	12.7(14.4)	8(8)	32(28)	50	9	2.1	2
4125R/L	8	125	132	87	38.1(40)	15.9(16.4)	10(9)	38(30)	63	9	3.8	2
4160R/L	10	160	166	107	50.8(40)	19.0(16.4)	11(9)	38(30)	63	9	5.7	2
4200R/L	12	200	206	130	47.625(60)	25.4(25.7)	14(14)	38(38)	63	9	8.2	3
4250R/L	16	250	256	180	47.625(60)	25.4(25.7)	14(14)	38(38)	63	9	13.5	3
4315R/L	20	315	321	240	47.625(60)	25.4(25.7)	14(14)	38(38)	63	9	21.1	4

(мм)
• () Метрическая система

Применяемые СМП

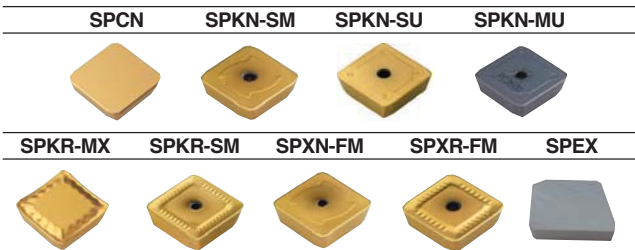

Обозначение	Тв. сплав с покрытием						Кермет	Тв. сплав				Стр.		
	NCM325	NCM335	PC3500	PC3600	PC3500	PC3545		PC6510	PC8110	PD2000	CN2000		CN20	G10
SPCN 1203EDR	•	•									•	•	•	•
1203EDL												•	•	•
1203EDR-G												•	•	•
1203EDER-RH					•									
1203EDSR-RH														
1203EDTR-RH				•										
1203EDR-S20														
SPKN 1203EDSR-SM														
1203EDER-SM														
1203EDER-MU														
1203EDSR-SU				•	•	•								
1203EDSL-SU				•										
SPKR 1203EDSR-MX	•	•												
1203EDSL-MX	•													
1203EDSR-SM														
SPXN 1203EDSR-FM				•										
1203EDER-FM														
SPXR 1203EDSR-FM														
SPEX 1203EDR/L-1														

Применяемые оправки

Обозначение	Оправка с хвостовиком NT	Оправка с хвостовиком BT	
		EPN	EPNM
EPN(M) 4080R/L	NT*□□(M/U)-FMA25.4-25	BT**□□-FMA25.4-□□	FMC27
4100R/L	NT*□□(M/U)-FMA31.75-□□	BT**□□-FMA31.75-□□	FMC32
4125R/L	NT*□□(M/U)-FMA38.1-□□	BT**□□-FMA38.1-□□	FMB40
4160R/L	NT*□□(M/U)-FMA50.8-□□	BT**□□-FMA50.8-□□	FMB40
4200R/L	NT*□□(M/U)-FMA47.625-25, KCP-8***	BT**□□-FMA47.625-□□	FMB60
4250R/L	NT*□□(M/U)-FMA47.625-25, KCP-8***	BT**□□-FMA47.625-□□	FMB60
4315R/L	KCP-8*** (Без центрального отверстия)		

*□□-NT(No) **□□-BT(No) ***Для больших диаметров

Рекомендации по выбору режимов резания и марки сплава

Обрабатываемые материалы	Режимы резания		Марка сплава
	V(м/мин)	Sz(мм/зуб)	
P	150 ~ 300	0.05 ~ 0.15	NCM325
	120 ~ 230	0.05 ~ 0.20	PC3500
	100 ~ 200	0.05 ~ 0.20	ST30A
M	50 ~ 200	0.05 ~ 0.20	PC9530
	50 ~ 120	0.05 ~ 0.20	ST30A
K	150 ~ 250	0.05 ~ 0.30	PC6510
	100 ~ 200	0.05 ~ 0.30	G10

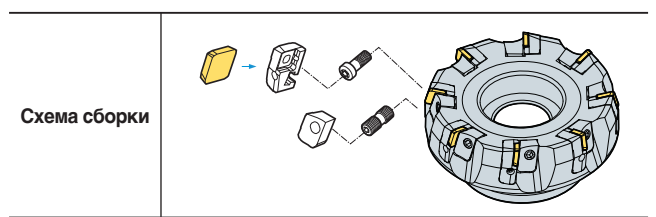

Комплектующие

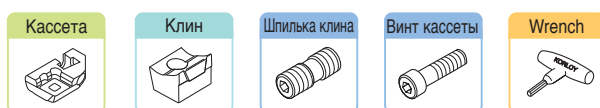

LEPN4R/L	WEPN4R/L	DHA0821F	LTX0514	HW40
LEPN4R1*/L1*		DHA0817F*		

* : Ø80 ~ Ø100

Применяемые СМП E20, E21 Присоединительные размеры смотреть на стр. E270~E272

• : Наличие на складе

EPN(M)5000+

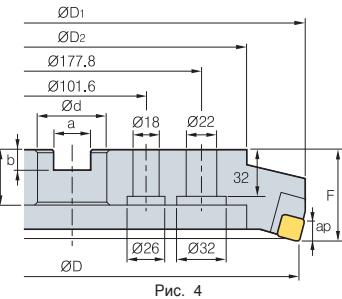
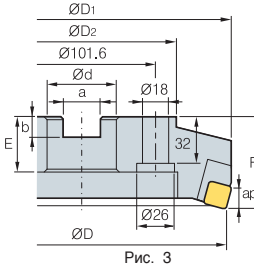
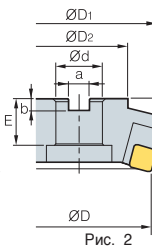
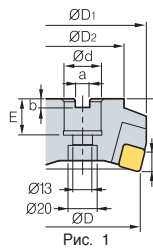

Обозначение		ØD	ØD1	ØD2	Ød	a	b	E	F	ap		Рис.
EPN(M) 5080R/L+	5	80	91	57	25.4(27)	9.5(12.4)	6(7)	25(22)	50	12	1.5	1
5100R/L+	6	100	110	67	31.75(32)	12.7(14.4)	8(8)	32(28)	50	12	2.1	2
5125R/L+	8	125	134	87	38.1(40)	15.9(16.4)	10(9)	38(30)	63	12	3.9	2
5160R/L+	10	160	169	107	50.8(40)	19.0(16.4)	11(9)	38(30)	63	12	5.7	2
5200R/L+	12	200	209	130	47.625(60)	25.4(25.7)	14(14)	38(38)	63	12	8.4	3
5250R/L+	16	250	259	180	47.625(60)	25.4(25.7)	14(14)	38(38)	63	12	13.6	3
5315R/L+	20	315	324	240	47.625(60)	25.4(25.7)	14(14)	38(38)	63	12	21.6	4

() Метрическая система

Применяемые СМП

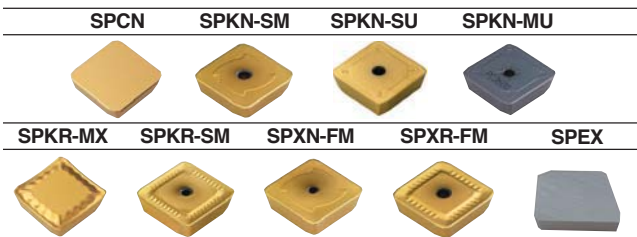

Обозначение	Тв. сплав с покрытием				Кермет				Тв. сплав		Стр.				
	NCM325	NCM335	PC3500	PC3600	PC3545	PC9530	PC8510	PC8110	PD2000	CN2000		CN30	H01	G10	ST30A
SPCN 150412T															
1504EDR	•											•	•	•	
1504EDSR	•														
1504EDL						•									
1504EDR-G												•			
1504EDER-RH					•	•									
1504EDSR-RH						•									
1504EDTR-RH			•												
1504EDR-S20						•									
SPKN 1504ESR-SM															
1504EDER-SM															
1504EDSR-MU				•											
1504EDSR-SU				•	•	•									
1504EDSL-SU				•											
SPKR 1504EDR-MX	•														
1504EDSR-MX	•	•													
1504EDSR-SM															
SPXN 1504EDSR-FM			•		•										
1504EDER-FM															
SPXR 1504EDSR-FM					•										
SPEX 1504EDR/L-1															

Применяемые оправки

Обозначение	Оправка с хвостовиком NT	Оправка с хвостовиком BT	
		EPN	EPNM
EPN(M) 5080R/L	NT*□□ (M/U)-FMA25.4-25	BT**□□-FMA25.4-□□	FMC27
5100R/L	NT*□□ (M/U)-FMA31.75-□□	BT**□□-FMA31.75-□□	FMC32
5125R/L	NT*□□ (M/U)-FMA38.1-□□	BT**□□-FMA38.1-□□	FMB40
5160R/L	NT*□□ (M/U)-FMA50.8-□□	BT**□□-FMA50.8-□□	FMB40
5200R/L	NT*□□ (M/U)-FMA47.625-25, KCP-8***	BT**□□-FMA47.625-□□	FMB60
5250R/L	NT*□□ (M/U)-FMA47.625-25, KCP-8***	BT**□□-FMA47.625-□□	FMB60
5315R/L	KCP-8*** (Без центрального отверстия)		

*□□-NT(No) **□□-BT(No) ***Для больших диаметров

Рекомендации по выбору режимов резания и марки сплава

Обрабатываемые материалы	Режимы резания		Марка сплава
	V(м/мин)	Sz(мм/зуб)	
P	150 ~ 300	0.05 ~ 0.15	NCM325
	120 ~ 230	0.05 ~ 0.20	PC3500
	100 ~ 200	0.05 ~ 0.20	ST30A
M	50 ~ 200	0.05 ~ 0.20	PC9530
	50 ~ 120	0.05 ~ 0.20	ST30A
K	150 ~ 250	0.05 ~ 0.30	PC6510
	100 ~ 200	0.05 ~ 0.30	G10

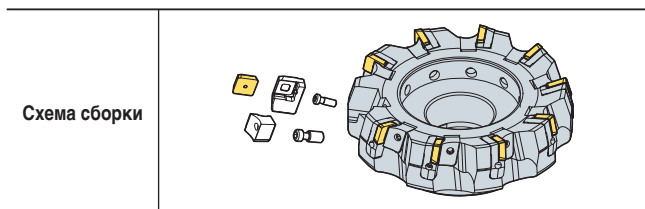

Комплектующие

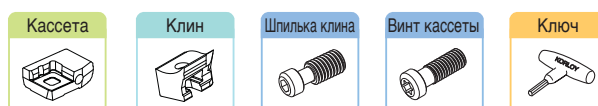

LEPN5R/L WHPS5R/L WHX0817 LTX0514 HW40
LEPN5R1*/L1* WHX0813*

*: Ø80

PF(M)4000

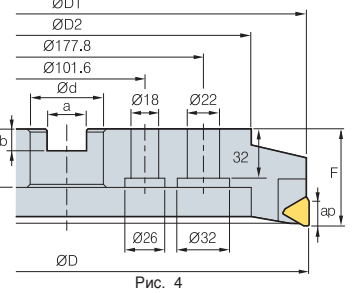
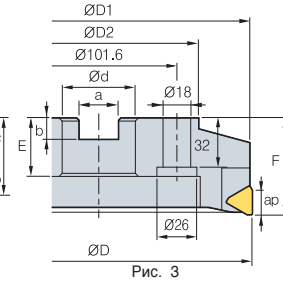
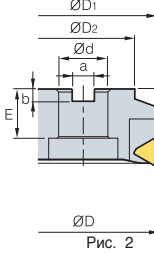
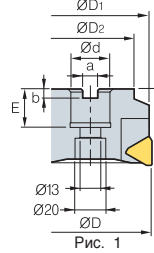

• AR : 15°
• RR : 14°

Обозначение		øD	øD1	øD2	ød	a	b	E	F	ap		Рис.
PF(M)												
4080R/L	4	80	79	57	25.4(27)	9.5(12.4)	6(7)	25(22)	50	16	1.2	1
4100R/L	4	100	97	67	31.75(32)	12.7(14.4)	8(8)	32(28)	50	16	1.8	2
4125R/L	7	125	122	87	38.1(40)	15.9(16.4)	10(9)	38(30)	63	16	3.1	2
4160R/L	9	160	158	107	50.8(40)	19.0(16.4)	11(9)	38(30)	63	16	5.6	2
4200R/L	11	200	197	130	47.625(60)	25.4(25.7)	13.5(14)	38(38)	63	16	8.8	3
4250R/L	15	250	247	180	47.625(60)	25.4(25.7)	13.5(14)	38(38)	63	16	16	3
4315R/L	19	315	311	240	47.625(60)	25.4(25.7)	13.5(14)	38(38)	63	16	22	4

(мм)
• ()Метрическая система

Применяемые СМП

TFCN

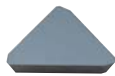

Обозначение	Тв. сплав с покрытием				Кермет		Тв. сплав			Стр.
	NCM325	NCM335	NC330	PC3500	PC3545	PC9530	PC6510	PC215K	PD2000	
TFCN 2203PFR										E21
2203PFL										

Применяемые оправки

Обозначение	Оправка с хвостиком NT	Оправка с хвостиком BT	
		PF	PFM
PF(M) 4080R/L	NT*□□(M/U)-FMA25.4-25-□□	BT**□□-FMA25.4-□□	FMC27
4100R/L	NT*□□(M/U)-FMA31.75-□□	BT**□□-FMA31.75-□□	FMC32
4125R/L	NT*□□(M/U)-FMA38.1-□□	BT**□□-FMA38.1-□□	FMB40
4160R/L	NT*□□(M/U)-FMA50.8-□□	BT**□□-FMA50.8-□□	FMB40
4200R/L	NT*□□(M/U)-FMA47.625-25, KCP-8***	BT**□□-FMA47.625-□□	FMB60
4250R/L	NT*□□(M/U)-FMA47.625-25, KCP-8***	BT**□□-FMA47.625-□□	FMB60
4315R/L	KCP-8*** (Без центрального отверстия)		

*□□-NT(No) **□□-BT(No) ***Для больших диаметров

Рекомендации по выбору режимов резания и марки сплава

Обрабатываемые материалы	Режимы резания		Марка сплава
	V(м/мин)	Sz(мм/зуб)	
P	150 ~ 300	0.05 ~ 0.15	NCM325 PC3500 ST30A
	120 ~ 230	0.05 ~ 0.20	
	100 ~ 200	0.05 ~ 0.20	
M	50 ~ 200	0.05 ~ 0.20	PC9530 ST30A
	50 ~ 120	0.05 ~ 0.20	
K	150 ~ 250	0.05 ~ 0.30	PC6510 G10
	100 ~ 200	0.05 ~ 0.30	

Схема сборки

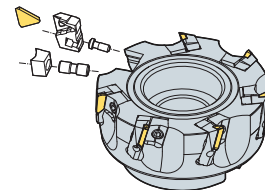

Комплектующие

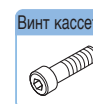
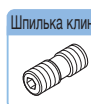

LPF4R/L
LPF4R1**/L1** WPF4R/L DHA0821F
DHA0817F* LTX0512 HW40

* : Ø80 ~ Ø100 / ** : Ø80 ~ Ø125

PPN(M)4000

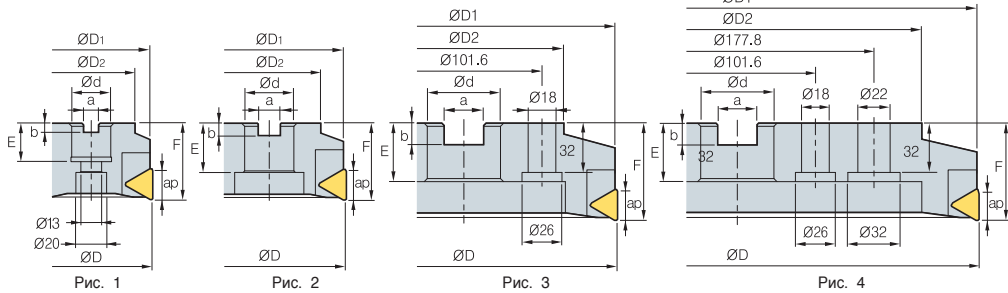
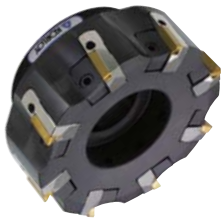

• AR : 7°
• RR : 0°

Обозначение		ØD	ØD ₁	ØD ₂	Ød	a	b	E	F	ap		Рис.
PPN(M) 4080R/L		80	79	57	25.4(27)	9.5(12.4)	6(7)	25(22)	50	18	1.3	1
4100R/L		100	99	67	31.75(32)	12.7(14.4)	8(8)	32(28)	50	18	1.9	2
4125R/L		125	124	87	38.1(40)	15.9(16.4)	10(9)	38(30)	63	18	3.5	2
4160R/L		160	158	107	50.8(40)	19.0(16.4)	11(9)	38(30)	63	18	5.6	2
4200R/L		200	198	130	47.625(60)	25.4(25.7)	14(14)	38(38)	63	18	8.1	3
4250R/L		250	248	180	47.625(60)	25.4(25.7)	14(14)	38(38)	63	18	13.3	3
4315R/L		315	313	240	47.625(60)	25.4(25.7)	14(14)	38(38)	63	18	21.4	4

() Метрическая система

Применяемые СМП

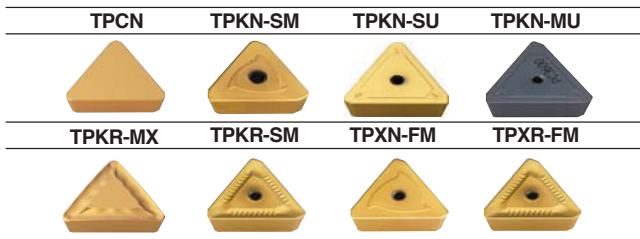

Обозначение	Тв. сплав с покрытием				Кермет		Тв. сплав			Стр.					
	NCM325	NCM335	PC3500	PC3600	PC3545	PC9530	PC8510	PD2000	CN2000		CN30	H01	G10	ST30A	ST20
TPCN 2204PDR	●														E22
2204PDR-G															
2204PDL															
2204PDSR	●														
2204PDTR															
2204PDR-RH															
TPKN 2204PDSR-SM					●										E22
2204PDER-SM					●										
2204PDSR-MU					●										
2204PDSR-SU					●										
TPKR 2204PDR-MX	●														E22
2204PDSR-MX	●														
2204PPR-MX	●														
TPXN 2204PDSR-FM					●										E22
2204PDER-FM					●										
TPXR 2204PDSR-FM					●										E23

Применяемые оправки

Обозначение	Оправка с хвостовиком NT	Оправка с хвостовиком BT	
		PPN	PPNM
PPN(M) 4080R/L	NT*□□ (MU)-FMA25.4-25	BT**□□ -FMA25.4 - □□	FMC27
4100R/L	NT*□□ (MU)-FMA31.75 - □□	BT**□□ -FMA31.75 - □□	FMC32
4125R/L	NT*□□ (MU)-FMA38.1 - □□	BT**□□ -FMA38.1 - □□	FMB40
4160R/L	NT*□□ (MU)-FMA50.8 - □□	BT**□□ -FMA50.8 - □□	FMB40
4200R/L	NT*□□ (MU)-FMA47.625-25, KCP-8***	BT**□□ -FMA47.625-□□	FMB60
4250R/L	NT*□□ (MU)-FMA47.625-25, KCP-8***	BT**□□ -FMA47.625-□□	FMB60
4315R/L	KCP-8*** (Без центрального отверстия)		

*□□ -NT(No) **□□ -BT(No) ***Для больших диаметров

Рекомендации по выбору режимов резания и марки сплава

Обрабатываемые материалы	Режимы резания		Марка сплава
	V(м/мин)	Sz(мм/зуб)	
P	150 ~ 300	0.05 ~ 0.15	NCM325 PC3500 ST30A
	120 ~ 230	0.05 ~ 0.20	
	100 ~ 200	0.05 ~ 0.20	
M	50 ~ 200	0.05 ~ 0.20	PC9530 ST30A
	50 ~ 120	0.05 ~ 0.20	
K	150 ~ 250	0.05 ~ 0.30	PC6510 G10
	100 ~ 200	0.05 ~ 0.30	

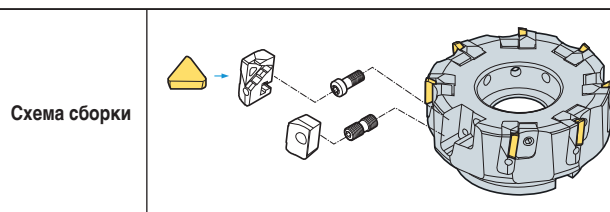

Комплектующие

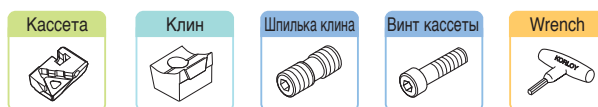

LPPN4R/L WPPN4R/L DHA0821F LTX0514 HW40
LPPN4R1*/L1* DHA0817F*

* : Ø80 ~ Ø100

ADS4000

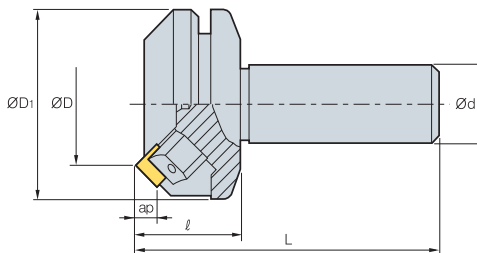

AA
45°
• AR : 15°
• RR : -3°

(мм)

Обозначение		ØD	ØD1	Ød	ℓ	L	ap	
ADS 4050R	3	50	75	32	40	120	6.5	1.8
4050RS42	3	50	75	42	40	120	6.5	2.2
4063R	4	63	87	32	40	120	6.5	2.3
4063RS42	4	63	87	42	40	120	6.5	2.7

• () Метрическая система

Применяемые СМП

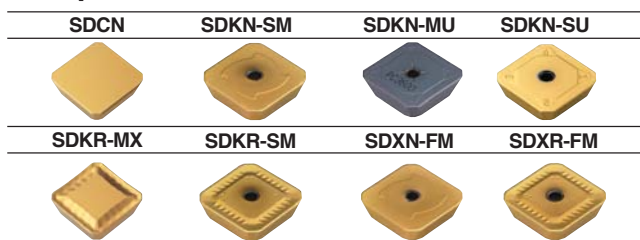

Обозначение	Тв. сплав с покрытием				Кермет			Тв. сплав		Стр.							
	NCM325	NCM335	NCM330	PC3600	PC3600	PC3500	PC3545	PC6510	PC215K		PC2100	CN2000	CN20	CN80	H01	G10	ST30A
SDCN 42M																	
42M-G																	
42MT																	
42MT-RH																	
42MT-S20																	
1203AEEN																	
1203AEEN-RH																	
1203AESN																	
1203AESN-RH																	
SDKN 1203AESN-SM																	
1203AEEN-SM																	
1203AEEN-MU																	
1203AEEN-SU																	
SDKR 1203AESN-MX																	
1203AETN-MX																	
1203AEN-MX																	
1203AESN-SM																	
SDXN 1203AESN-FM																	
1203AEEN-FM																	
SDXR 1203AESN-FM																	

Рекомендации по выбору режимов резания и марки сплава

Обрабатываемые материалы	Режимы резания		Марка сплава
	V(м/мин)	Sz(мм/зуб)	
P	150 ~ 300	0.05 ~ 0.15	NCM325 PC3500 ST30A
	120 ~ 230	0.05 ~ 0.20	
	100 ~ 200	0.05 ~ 0.20	
M	50 ~ 200	0.05 ~ 0.20	PC9530 ST30A
	50 ~ 120	0.05 ~ 0.20	
K	150 ~ 250	0.05 ~ 0.30	PC6510 G10
	100 ~ 200	0.05 ~ 0.30	

Схема сборки

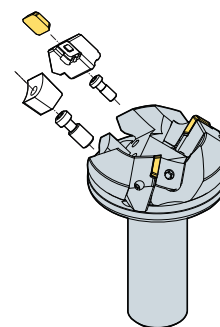

Комплектующие



LASS4R/L WASR/L WTX0817 LTX0512 TW25

Применяемые СМП E13, E14

• : Наличие на складе

ADS5000

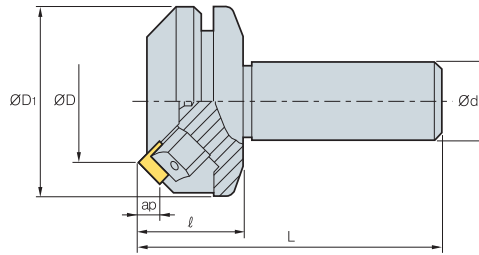

AA
45°
• AR : 15°
• RR : -3°

(мм)

Обозначение		$\varnothing D$	$\varnothing D_1$	$\varnothing d$	ℓ	L	ap	
ADS 5050R	3	50	75	32	40	120	8.5	1.9
5050R-S42	3	50	75	42	40	120	8.5	2.3
5063R	4	63	87	32	40	120	8.5	2.4
5063R-S42	4	63	87	42	40	120	8.5	2.8

• () Метрическая система

Применяемые СМП

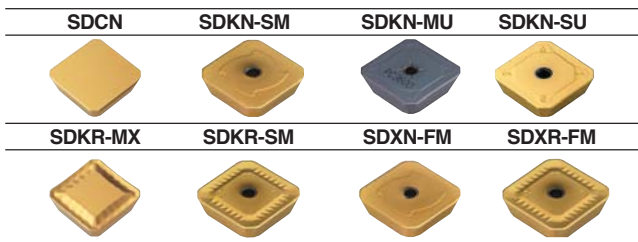

Обозначение	Тв. сплав с покрытием							Кермет			Тв. сплав			Стр.		
	NCM325	NCM335	PC3500	PC3600	PC3545	PC9530	PC6510	PC215K	PD2000	CN2000	CN20	CN30	H01		G10	ST30A
SDCN 53M																
53M-G																
53MT	•	•							•	•					•	
53MT-RH			•													
53MT-S20								•								
1504AEEN																
1504AEEN-RH					•			•								
1504AESN																
1504AESN-RH																
SDKN 1504AESN-SM																
1504AESN-SM																
1504AESN-MU				•												
1504AESN-SU				•	•											
SDKR 1504AESN-MX	•															
1504AETN-MX																
1504AEN-MX	•															
1504AESN-SM																
SDXN 1504AESN-FM																
1504AEEN-FM																
SDXR 1504AESN-FM																

Рекомендации по выбору режимов резания и марки сплава

Обрабатываемые материалы	Режимы резания		Марка сплава
	V(м/мин)	Sz(мм/зуб)	
P	150 ~ 300	0.05 ~ 0.15	NCM325
	120 ~ 230	0.05 ~ 0.20	PC3500
	100 ~ 200	0.05 ~ 0.20	ST30A
M	50 ~ 200	0.05 ~ 0.20	PC9530
	50 ~ 120	0.05 ~ 0.20	ST30A
K	150 ~ 250	0.05 ~ 0.30	PC6510
	100 ~ 200	0.05 ~ 0.30	G10

Схема сборки

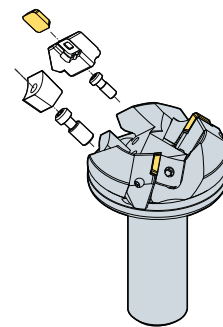

Комплектующие



LASS5R/L



WASR/L



WTX0817

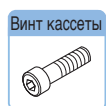

LTX0512



TW25



PES2000/3000/4000



2000/3000 Тип

4000 Тип



Рис. 1



Рис. 2

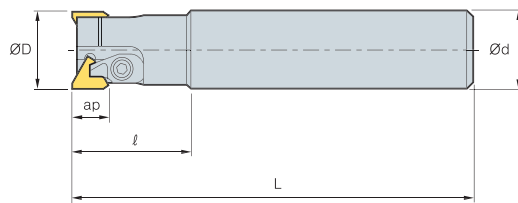

AA
90°
• AR : 10°~15°
• RR : 2°~3°

(мм)

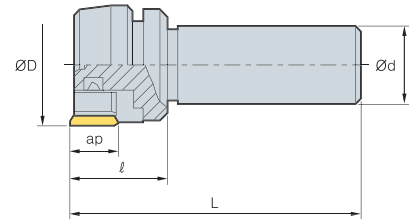
Обозначение			ØD	Ød	ℓ	L	ap		Рис.
PES	2020R	2	20	20	30	110	8	0.3	1
	2025R	2	25	25	35	120	8	0.5	1
PES	3030R	2	30	32	45	160	13	0.9	1
	3032R	2	32	32	45	160	13	1.0	1
	3033R	2	33	32	45	160	13	1.1	1
	3035R	2	35	32	45	160	13	1.2	1
	3036R	2	36	32	45	160	13	1.3	1
	3040R	2	40	32	45	160	13	1.4	1
	PES	4050R	3	50	32	40	120	16.5	1.2
4050R-S42		3	50	42	40	120	16.5	1.5	2
4063R		4	63	32	40	120	16.5	1.5	2
4063R-S42		4	63	42	40	120	16.5	1.8	2

Применяемые СМП

		TECN				TEEN												
Тип	Обозначение	NCM325	NCM335	NC5330	PC3500	PC3545	PC9530	PC6510	PC215K	PD2000	CN2000	CN20	CN30	H01	G10	ST30A	ST20	Стр.
2000 Тип	TECN 22R																	E21
	22TR																	
3000 Тип	TECN 32R																	E21
	32TR																	
	32TR-S20																	
4000 Тип	TEEN 43R																	E21
	43R-G																	
	43TR																	
	43TR-S20																	
	43TR-ZH																	

Рекомендации по выбору режимов резания и марки сплава

Обрабатываемые материалы	Режимы резания		Марка сплава
	V(м/мин)	Sz(мм/зуб)	
P	150 ~ 300	0.05 ~ 0.15	NCM325
	120 ~ 230	0.05 ~ 0.20	PC3500
	100 ~ 200	0.05 ~ 0.20	ST30A
M	50 ~ 200	0.05 ~ 0.20	PC9530
	50 ~ 120	0.05 ~ 0.20	ST30A
K	150 ~ 250	0.05 ~ 0.30	PC6510
	100 ~ 200	0.05 ~ 0.30	G10

Схема сборки

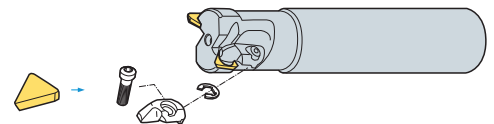

Комплектующие

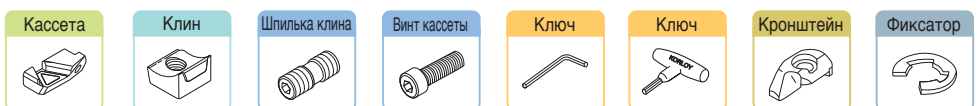

2000 Тип	-	-	-	CHX0407	HW25L	-	CH4R1	ER03
3000 Тип	-	-	-	CHX0510	HW30L	-	CH5R1	ER04
4000 Тип	LPTS4R/L	WPTSR	DHA0815	LTX0512	-	HW40	-	-

AFO(M) 4000

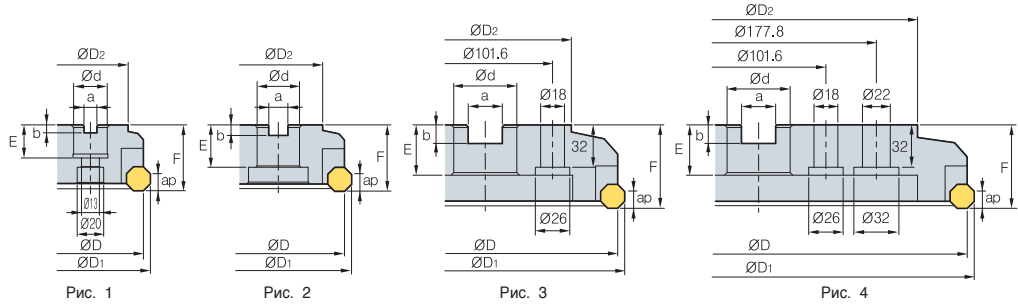

• AR : 15°
• RR : 5°

(мм)

Обозначение		ØD	ØD ₁	ØD ₂	Ød	a	b	E	F	ap		Рис.
AFO(M) 4080R/L	5	80	88	60	25.4(27)	9.5(12.4)	6(7)	25(22)	50	6.5	1.4	1
4100R/L	6	100	108	80	31.75(32)	12.7(14.4)	8(8)	32(28)	50	6.5	2.0	1
4125R/L	8	125	133	100	38.1(40)	15.9(16.4)	10(9)	38(30)	63	6.5	3.1	1

• () Метрическая система

Применяемые СМП

	OFCW	OFKT-MF	OFKT-MM	OFKT-MA												
Обозначение	Тв. сплав с покрытием				Кермет	Тв. сплав				Стр.						
	NCM325	NCM335	PC3500	PC3545	PC9530	PC6510	PD215K	PD2000	CN2000	CN20	CN30	H01	G10	ST30A	ST20	
OFCW 05T3SN																E10
05T3FN																
05T308FN																
OFKT 05T3SN-MF	••	••			•											E11
05T308SN-MF	••	••														
05T3SN-MM	••	••			•											
05T308SN-MM	••	••														
05T3FN-MA													•			
05T3EN-MA																

Применяемые оправки

Обозначение	Оправка с хвостовиком NT		Оправка с хвостовиком BT	
	AFO	AFOM	AFO	AFOM
AFO(M) 4080R/L	NT*□□(M/U)-FMA25.4-25	BT**□□-FMA25.4-□□	FMC27	
4100R/L	NT*□□(M/U)-FMA31.75-□□	BT**□□-FMA31.75-□□	FMC32	
4125R/L	NT*□□(M/U)-FMA38.1-□□	BT**□□-FMA38.1-□□	FMB40	

*□□-NT(No) **□□-BT(No) ***Для больших диаметров

Рекомендации по выбору режимов резания и марки сплава

Обрабатываемые материалы	Режимы резания		Марка сплава
	V(м/мин)	Sz(мм/зуб)	
P	150 ~ 300	0.05 ~ 0.15	NCM325
	120 ~ 230	0.05 ~ 0.20	PC3500
	100 ~ 200	0.05 ~ 0.20	ST30A
M	50 ~ 200	0.05 ~ 0.20	PC9530
	50 ~ 120	0.05 ~ 0.20	ST30A
K	150 ~ 250	0.05 ~ 0.30	PC6510
	100 ~ 200	0.05 ~ 0.30	G10

Схема сборки

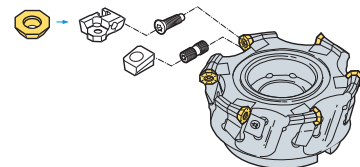

Комплектующие



LAF04R/L



WAFO4R/L

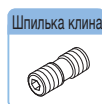

DHA0815

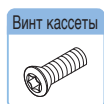

FTKA0408



TW15S

AFO(M)5000

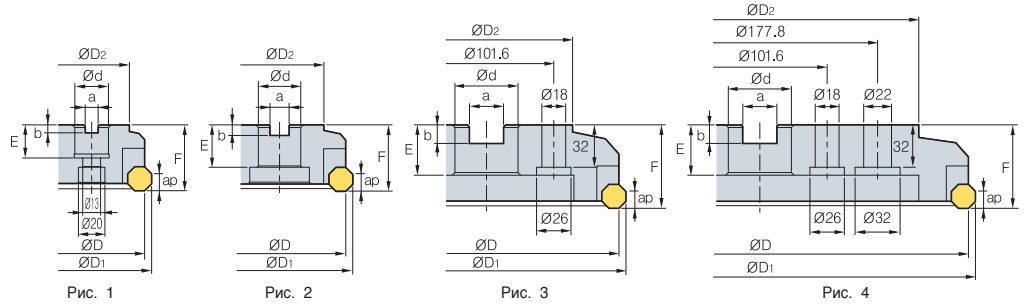

AA
45°
• AR : 15°
• RR : 5°

Обозначение		øD	øD ₁	øD ₂	ød	a	b	E	F	ap		Рис.
AFO(M) 5080R/L	5	80	91	60	25.4(27)	9.5(12.4)	6(7)	25(22)	50	9.5	1.4	1
5100R/L	6	100	111	80	31.75(32)	12.7(14.4)	8(8)	32(28)	50	9.5	2.0	2
5125R/L	8	125	136	100	38.1(40)	15.9(16.4)	10(9)	38(30)	63	9.5	3.1	2
5160R/L	10	160	171	120	50.8(40)	19.0(16.4)	11(9)	38(30)	63	9.5	5.2	2
5200R/L	12	200	211	130	47.625(60)	25.4(25.7)	13.5(14)	38(38)	63	9.5	7.5	3
5250R/L	16	250	261	180	47.625(60)	25.4(25.7)	13.5(14)	38(38)	63	9.5	16.1	3
5315R/L	20	315	326	240	47.625(60)	25.4(25.7)	13.5(14)	38(38)	63	9.5	22.8	4

() Метрическая система

Применяемые СМП

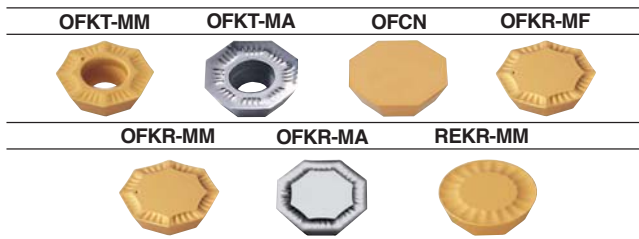

Обозначение	Тв. сплав с покрытием				Кермет	Тв. сплав				Стр.						
	NCM325	NCM335	PC3500	PC3545		PC9530	PC6510	PC215K	PD2000		CN2000	CN20	CN30	H01	G10	ST30A
OFCN 0704SN	●															E10
0704FN		●														
070408SN			●													
070408FN				●												
OFKR 0704SN-MF	●	●														E11
070408SN-MF	●	●														
0704SN-MM	●	●	●	●	●											
070408SN-MM	●															
0704FN-MA												●				E11
0704EN-MA												●				
OFKT 0704SN-MM	●															
0704FN-MA													●			E11
0704EN-MA																
REKR 170400-MM																E13

Применяемые оправки

Обозначение	Оправка с хвостовиком NT	Оправка с хвостовиком BT	
		AFO	AFOM
AFO(M)5080R/L	NT*□□(M/U)-FMA25.4-25	BT**□□-FMA25.4-□□	FMC27
5100R/L	NT*□□(M/U)-FMA31.75-□□	BT**□□-FMA31.75-□□	FMC32
5125R/L	NT*□□(M/U)-FMA38.1-□□	BT**□□-FMA38.1-□□	FMB40
5160R/L	NT*□□(M/U)-FMA50.8-□□	BT**□□-FMA50.8-□□	FMB40
5200R/L	NT*□□(M/U)-FMA47.625-25, KCP-8**	BT**□□-FMA47.625-□□	FMB60
5250R/L	NT*□□(M/U)-FMA47.625-25, KCP-8**	BT**□□-FMA47.625-□□	FMB60
5315R/L	KCP-8*** (Без центрального отверстия)		

*□□-NT(No) **□□-BT(No) ***Для больших диаметров

Рекомендации по выбору режимов резания и марки сплава

Обрабатываемые материалы	Режимы резания		Марка сплава
	V(м/мин)	Sz(мм/зуб)	
P	150 ~ 300	0.05 ~ 0.15	NCM325 PC3500 ST30A
	120 ~ 230	0.05 ~ 0.20	
	100 ~ 200	0.05 ~ 0.20	
M	50 ~ 200	0.05 ~ 0.20	PC9530 ST30A
	50 ~ 120	0.05 ~ 0.20	
K	150 ~ 250	0.05 ~ 0.30	PC6510 G10
	100 ~ 200	0.05 ~ 0.30	

Схема сборки

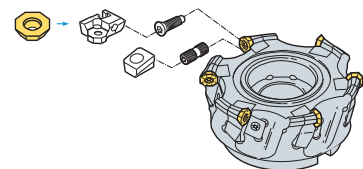

Комплектующие

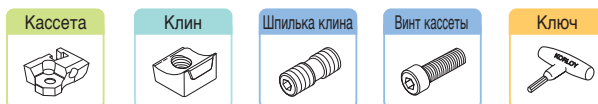

LAF05R/L WEFR/L DHA0821F LTX0512 HW40
LAF05R*/L-1*

* : Ø80 ~ Ø100

Применяемые СМП E10, E11, E13 Присоединительные размеры смотреть на стр. E270-E272

● : Наличие на складе

Специальная геометрия режущей кромки снижает силу резания более чем на 20% по сравнению с классической.

Power Buster

- Специальная геометрия режущей кромки снижает силу резания более чем на 20% по сравнению с классической.
- Наличие специальных стружкоделительных канавок на режущей кромке способствует снижению сил резания и обеспечивает устойчивое строжкодробление на мелкие элементы.
- Высокая экономичность применения СМП за счет их двухсторонней геометрии и 6 режущих кромок.
- Возможность выбора фрез с различными углами в плане 40° и 80°.
- Возможность применения высоких подач и гулбин резания при черновой обработке сталей и чугунов.

Система обозначения фрез серии

PB	A	C	M	5	250	R/L	-M
Power Buster	Угол в плане	Тип фрез	оправки Тип	Диаметр вписанной окружности	Диаметр фрезы	Исполнение	Шаг зубьев
Power buster	A : 45° Z : 80°	C : Cutter S : Shank	M : Метрическая I : Дюймовое	5 : 15.875	ØD : 250	R : Правое L : Левое	Не обозначено : Крупный M : Мелкий

Общие характеристики СМП

1 Главная режущая кромка

- Низкие силы резания.
- Устойчивое дробление стружки на мелкие элементы.
- 6 режущих кромок СМП
- Специально разработанная геометрия для высокопроизводительной черновой обработки стали и чугуна.

Результаты сравнительных испытаний

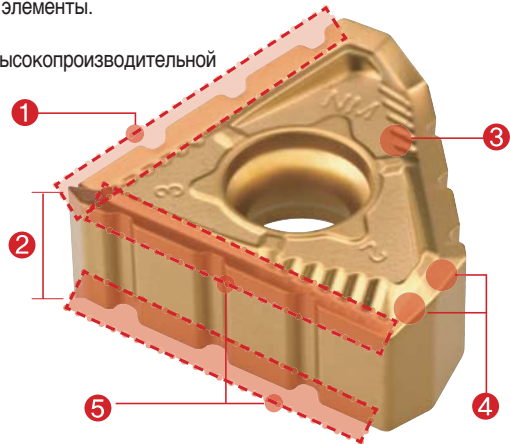
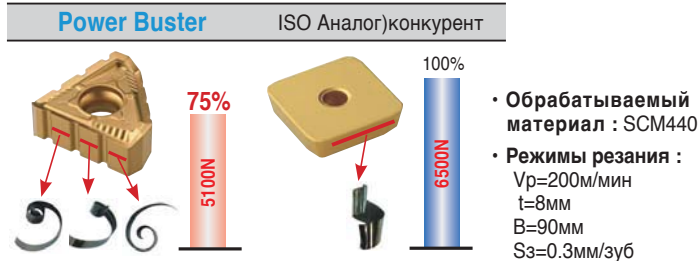

2 Толстые СМП

- Толстые СМП гарантируют высокую жесткость
- Сбалансированная конструкция СМП для стабильного монтажа



3 Стружколом

- Большой передний угол обеспечивающий низкие силы резания.
- Стабильное дробление стружки при различных подачах и глубинах резания.
- Наличие защитного уступа посадочного места СМП.



4 Вспомогательная режущая кромка

- Двойная вспомогательная режущая кромка.
- Специальная обеспечивает высокое качество обработанной поверхности.

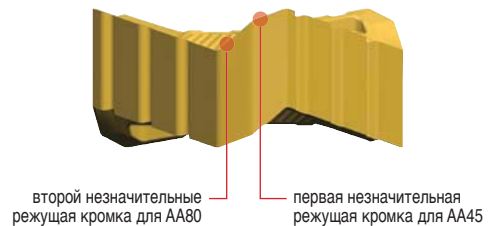

5 Шахматное расположение стружечных канавок

Первая режущая кромка СМП имеет стружечные канавки, которые перекрываются второй режущей кромкой СМП имеющей аналогичные канавки, расположенные со смещением относительно первых, образуя гладкую обработанную поверхность.

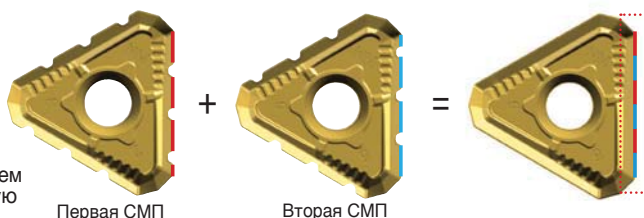

Окончательное формирование гладкой обработанной поверхности происходит при совместной работе всех зубьев



Общие характеристики

1 Система крепления винтом Простое и надежное крепление СМП

2 Установка опорной пластины

- Высокая точность позиционирования
- Высокая жесткость системы крепления

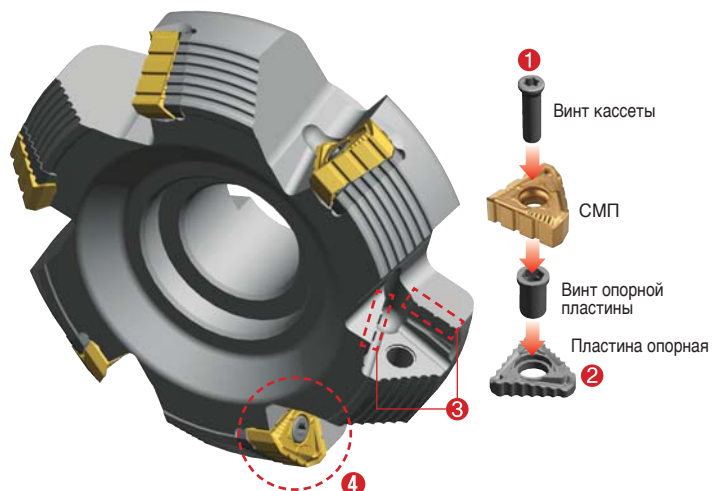
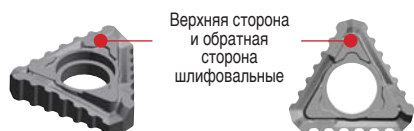

3 Установка СМП • Каждая СМП должна быть правильно установлена по отношению к канавкам на корпусе фрезы. СМП должны быть относительно друг друга зеркально ориентированы

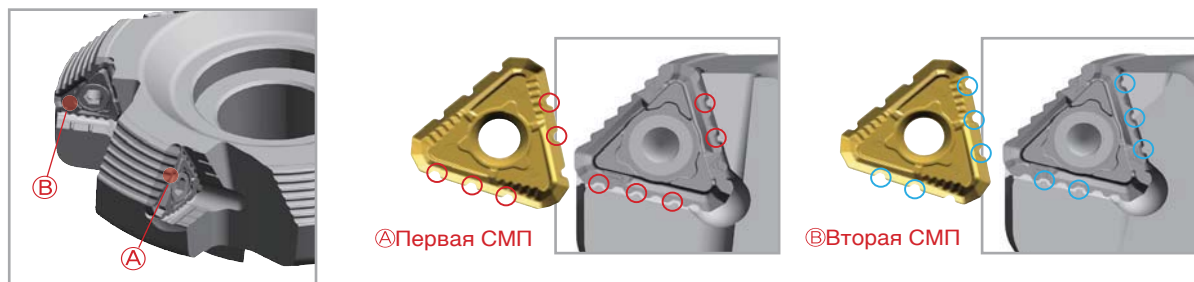

4 Сравнение установки СМП для фрез с различными углами в плане

- Для всех фрез с различными углами в плане применяется одна и та же СМП

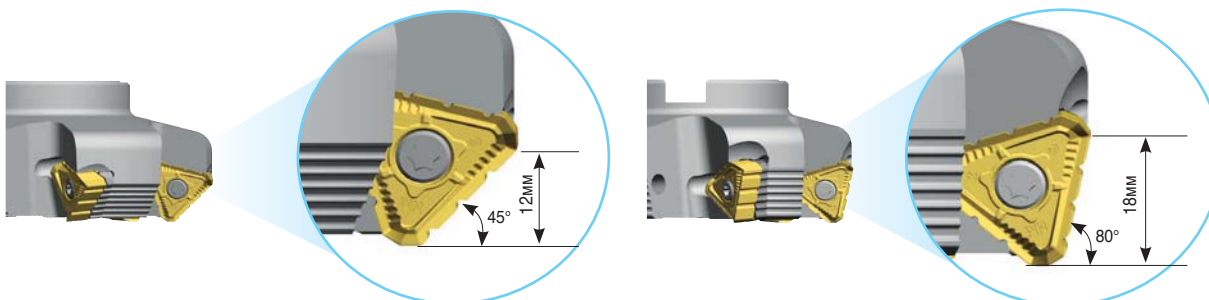

В вертикальной плоскости перекрытие стружечных канавок происходит с шагом примерно в 1 мм

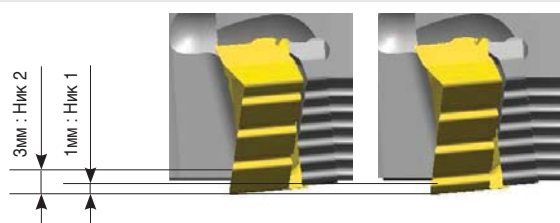

В вертикальной плоскости перекрытие стружечных канавок происходит с шагом примерно в 3 мм

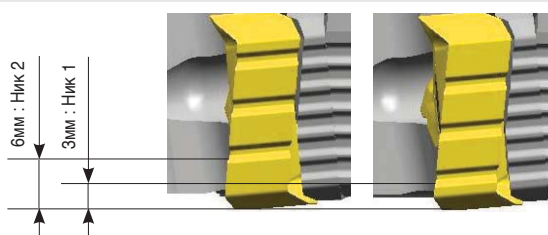

Рекомендации по выбору режимов резания и марки сплава

ISO	Обрабатываемые материалы	NC5330	NCM335	PC5300
		S _z , мм/зуб		
		0.1-0.2-0.3	0.1-0.2-0.3	0.1-0.2-0.3
P	Углеродистые стали	300-250-200	280-230-180	250-200-160
	Низколегированные стали	250-210-180	230-180-150	180-150-120
	Штамповые стали	180-150-130	160-130-110	140-120-100
K	Серые чугуны	280-220-180	250-200-160	220-180-150
	Ковкие чугуны	250-200-160	230-180-150	180-150-130
	Легированные чугуны	230-180-150	210-160-130	160-120-120

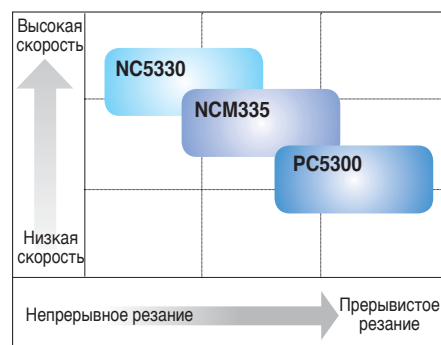

Результаты сравнительных испытаний

Блок цилиндров (кораблестроение). Материал: Чугун

Ширина фрезерования, B=160 мм
Глубина резания, t=10 мм

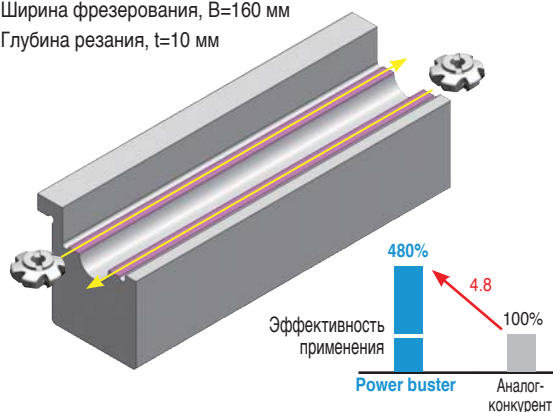

Основные характеристики	Power Buster	Аналог-конкурент
Диаметр фрезы	200мм	200мм
	12 зубьев	12 зубьев
Марка сплава	NC9025	Чугуна, PVD покрытие
V _p	170м/мин	130м/мин
S _z	0.24мм/зуб	0.16мм/зуб
t	10 мм i=2	4 мм i=5
T маш	28.2мин	137.5мин
Производительность выше в 4.8 раза		• Односторонняя четырехсторонняя СМП

Корпус (тяжелое машиностроение) Материал: Легированная сталь

Ширина фрезерования, B=160 мм
Глубина резания, t=10 мм

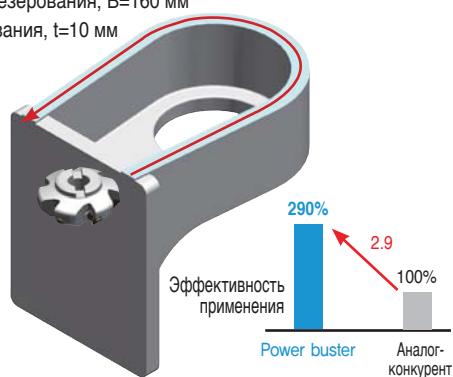

Основные характеристики	Power Buster	Аналог-конкурент
Диаметр фрезы	125мм	100мм
	8 зубьев	8 зубьев
Марка сплава	NCM335	Чугуна, PVD покрытие
V _p	180м/мин	150м/мин
S _z	0.15мм/зуб	0.10мм/зуб
t	5 мм i=2	2,5 мм i=4
T маш	5мин	14.7мин
Производительность выше в 2.9 раза		• Односторонняя четырехсторонняя СМП



РВАС(М)5000



Рис. 1



Рис. 2

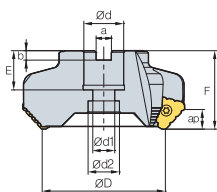

Рис. 3

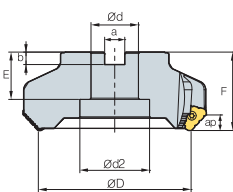

Рис. 4

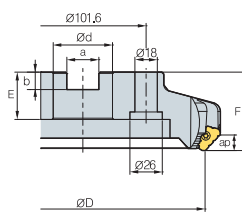

AA
45°
• AR : -5°
• RR : -11°

(мм)

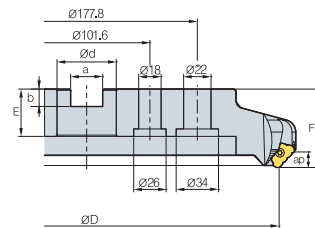
Обозначение		øD	ød	ød1	ød2	a	b	E	F	ap	Рис.		
Грубый шаг	РВАС(М)	5080R/L	4	80	25.4(27)	14	20	9.5(12.4)	6(7)	25(22)	50	12	1
		5100R/L	4	100	31.75(32)	-	45	12.7(14.4)	8(8)	32(28)	50	12	2
		5125R/L	6	125	38.1(40)	-	56	15.9(16.4)	10(9)	38(32)	63	12	2
		5160R/L	8	160	50.8(40)	-	100	19(16.4)	11(9)	38(32)	63	12	2
		5200R/L	10	200	47.625(60)	-	-	25.4(25.7)	14(14)	38(38)	63	12	3
		5250R/L	12	250	47.625(60)	-	-	25.4(25.7)	14(14)	38(38)	63	12	3
5315R/L	14	315	47.625(60)	-	-	25.4(25.7)	14(14)	38(38)	63	12	4		
Грубый шаг	РВАС(М)	5080R/L-M	6	80	25.4(27)	14	20	9.5(12.4)	6(7)	25(22)	50	12	1
		5100R/L-M	6	100	31.75(32)	-	45	12.7(14.4)	8(8)	32(28)	50	12	2
		5125R/L-M	8	125	38.1(40)	-	56	15.9(16.4)	10(9)	38(32)	63	12	2
		5160R/L-M	10	160	50.8(40)	-	100	19(16.4)	11(9)	38(32)	63	12	2
		5200R/L-M	12	200	47.625(60)	-	-	25.4(25.7)	14(14)	38(38)	63	12	3
		5250R/L-M	14	250	47.625(60)	-	-	25.4(25.7)	14(14)	38(38)	63	12	3
5315R/L-M	16	315	47.625(60)	-	-	25.4(25.7)	14(14)	38(38)	63	12	4		

• () Метрическая система

Применяемые СМП

TNMX-NM



Обозначение	Тв. сплав с покрытием									Кермет			Тв. сплав				Стр.	
	NCM325	NCM335	NC5330	PC3500	PC5300	PC3545	PC9630	PC6510	PC215K	PD2000	CN2000	CN20	CN30	H01	G10	ST30A		ST20
TNMX 2710AZNR-NM		●	●	●	●		●											E21
2710AZNL-NM																		

Применяемые оправки

Обозначение	Применяемые оправки		
	РВАС	РВАСМ	
РВАС	5080HR-□	BT□□-FMA25.4-□□	BT□□-FMC27-□□
(РВАСМ)	5100HR-□	BT□□-FMA31.75-□□	BT□□-FMC32-□□
	5125HR-□	BT□□-FMA38.1-□□	BT□□-FMB40-□□
	5160R-□	BT□□-FMA50.8-□□	BT□□-FMC40-□□
	5200R-□		
	5250R-□	BT□□-FMA47.625-□□	BT□□-FMB60-□□
	5315R-□		

Комплектующие

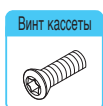

FTGA0518



ST53AZR



SHXN0712F



TW20-100



PBZC(M)5000



Рис. 1



Рис. 2

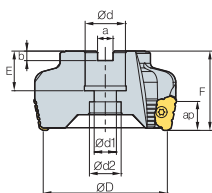

Рис. 3

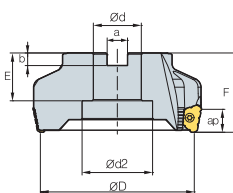

Рис. 4

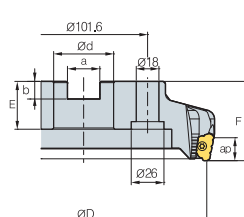

AA
80° • AR : -5°
• RR : -12°

(мм)

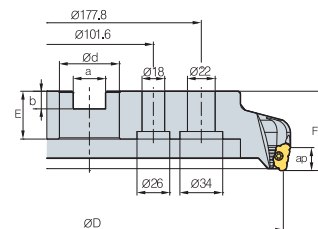
Обозначение			$\varnothing D$	$\varnothing d$	$\varnothing d_1$	$\varnothing d_2$	a	b	E	F	ap	Рис.
Грубый шаг	PBZC(M) 5080R/L	4	80	25.4(27)	14	20	9.5(12.4)	6(7)	25(22)	50	18	1
	5100R/L	4	100	31.75(32)	-	45	12.7(14.4)	8(8)	32(28)	50	18	2
	5125R/L	6	125	38.1(40)	-	56	15.9(16.4)	10(9)	38(32)	63	18	2
	5160R/L	8	160	50.8(40)	-	100	19(16.4)	11(9)	38(32)	63	18	2
	5200R/L	10	200	47.625(60)	-	-	25.4(25.7)	14(14)	38(38)	63	18	3
	5250R/L	12	250	47.625(60)	-	-	25.4(25.7)	14(14)	38(38)	63	18	3
Грубый шаг	PBZC(M) 5315R/L	14	315	47.625(60)	-	-	25.4(25.7)	14(14)	38(38)	63	18	4
	PBZC(M) 5080R/L-M	6	80	25.4(27)	14	20	9.5(12.4)	6(7)	25(22)	50	18	1
	5100R/L-M	6	100	31.75(32)	-	45	12.7(14.4)	8(8)	32(28)	50	18	2
	5125R/L-M	8	125	38.1(40)	-	56	15.9(16.4)	10(9)	38(32)	63	18	2
	5160R/L-M	10	160	50.8(40)	-	100	19(16.4)	11(9)	38(32)	63	18	2
	5200R/L-M	12	200	47.625(60)	-	-	25.4(25.7)	14(14)	38(38)	63	18	3
5250R/L-M	14	250	47.625(60)	-	-	25.4(25.7)	14(14)	38(38)	63	18	3	
5315R/L-M	16	315	47.625(60)	-	-	25.4(25.7)	14(14)	38(38)	63	18	4	

• () Метрическая система

Применяемые СМП

TNMX-NM



Обозначение	Тв. сплав с покрытием								Кермет			Тв. сплав				Стр.		
	NCM325	NCM335	NC5330	PC3500	PC5300	PC3645	PC9630	PC6510	PC215K	PD2000	CN2000	CN20	CN30	H01	G10		ST30A	ST20
TNMX 2710AZNR-NM 2710AZNL-NM		●	●	●	●		●											E21

Применяемые оправки

Обозначение	Применяемые оправки	
	PBZC	PBZCM
PBZC (PBZCM) 5080HR-□	BT□□-FMA25.4-□□	BT□□-FMC27-□□
5100HR-□	BT□□-FMA31.75-□□	BT□□-FMC32-□□
5125HR-□	BT□□-FMA38.1-□□	BT□□-FMB40-□□
5160R-□	BT□□-FMA50.8-□□	BT□□-FMC40-□□
5200R-□		
5250R-□	BT□□-FMA47.625-□□	BT□□-FMB60-□□
5315R-□		

Комплектующие

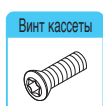

Винт кассеты



Пластина опорная



Винт опорной пластины



Ключ

FTGA0518

ST53AZR

SHXN0712F

TW20-100

Фрезы серии Rich Mill обеспечивают высокую экономичность обработки за счет применения двухсторонних СМП

Rich Mill серия

- Новые фрезы серии Rich Mill являются высоко экономичным инструментом за счет применения пластин с двухсторонней геометрией
- Специальная геометрия СМП снижают силы резания и увеличивают срок службы инструмента
- Серия Rich Mill имеет большой диапазон применения: обработка сталей, нержавеющей стали, чугуна и алюминия
- Отрицательная геометрия пластин способствует повышению стойкости этого инструмента.
- Rich Mill фрезы имеют комбинированное крепление СМП выполненное при помощи винта и клина

Система крепления винтом



Винт для крепления адаптера
(50 ~ 125 винт под шестигульный ключ)



Винт для крепления фрезы
(160 ~ 250 крепежный винт для основных торцевых фрез)

Rich Mill Series



Система обозначения фрез серии «Rich Mill»

режущих граней	Угол в плане	Тип фрез	оправки Тип	Диаметр вписанной окружности	Диаметр инструмента	Исполнение	Число зубьев
RM4 : режущих граней-4 RM8 : режущих граней-8 RM16 : режущих граней-16 RMT8 : режущих граней-8 (Крепление клином) RMH8 : режущих граней-8 (Пластина опорная)	A : 45° D : 30° E : 15° F : 5° P : 0° Q : 2° Z : Вертикальные	C : насадная S : концевая	M : Метрическое A : дюймовая	3 : 9.525 4 : 12.7 5 : 15.875	Ø100	R : правое L : левое Система охлаждения H : три отверстия Unmarked : без охлаждения	не указано – уменьшенное M : стандартное H : увеличенное тип крепления LT : крепление клином



Rich Mill RM8

Общие характеристики СМП

- ▶ Двухсторонние СМП имеют высокую экономичность применения, так как имеют 8 режущих граней.
- ▶ Большой передний угол СМП обеспечивает высокое качество поверхности и применяется для обработки сталей, нержавеющей сталей, чугунов и алюминия.
- ▶ Специальная геометрия СМП обеспечивает высокие стойкостные показатели при обработке различных материалов.
- ▶ Широкий выбор стружколомов позволяет существенно повысить эффективность фрезирования. Фрезы Rich Mill позволяют работать на больших скоростях с малыми энергозатратами.



Система охлаждения фрез









- ▶ Применение СОЖ улучшает отвод стружки из зоны резания и охлаждает инструмент. Система охлаждения подводит СОЖ через корпус к режущим кромкам.

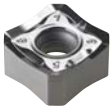

Отверстия под СОЖ для легкого отвода стружки.

СОЖ подается в зону резания для улучшения отвода стружки и охлаждения.

Общие характеристики СМП

СМП	Режущая кромка	Общие характеристики
Обработка алюминия МА 		Снижение сил резания за счет положительной геометрии передней поверхности. Препятствие наростообразованию. Высокое качество обработки.
Чистовое фрезирование MF 		Специальная геометрия передней поверхности для обработки вязких материалов: нержавеющей сталей, марганцовистых сталей и т.д.
Универсальное применение MM 		Применение в широком диапазоне режимов резания при обеспечении высокой стойкости СМП.
Wiper W 		Уменьшение шероховатости поверхности по сравнению с применением стружколомов MM и MF.

Общие характеристики фрез СМП

СМП	Передняя поверхность	Общие характеристики
	Вид-А 	Положительный главный передний угол способствует снижению сил резания.
	Вид-В 	Специальная геометрия вспомогательной режущей кромки улучшает качество поверхности.
	Стружколом 	Снижение сил резания за счет высокого переднего угла.



Rich Mill RM8

Общие характеристики резания

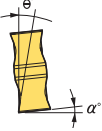
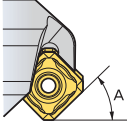
Корпус фрезы	Геометрия установки СМП	Общие характеристики
		Передний угол СМП создает при установке положительную геометрию и снижает силы резания.
		Высокая эффективность обработки плоскостей и наклонных поверхностей. • RM8A A=45° • RM8E A=75° • RM8Q A=88°

Рекомендуемые режимы резания

ISO	Марка сплава	SNM(E)X1206A(E)NN-MF		SNM(E)X1206A(E)NN-MM		SNEX1206A(E)NN-MA		t max	SNM(E)X1507A(E)NN-MF		SNM(E)X1507A(E)NN-MM		t max
		V(м/мин)	Sz(мм/зуб)	V(м/мин)	Sz(мм/зуб)	V(м/мин)	Sz(мм/зуб)		V(м/мин)	Sz(мм/зуб)	V(м/мин)	Sz(мм/зуб)	
P	NC5330	-	-	150~300	0.10~0.35	-	-	RM8A 6.0мм	-	-	150~300	0.10~0.35	RM8A 7.5мм
	NCM325	200~300	0.05~0.30	150~300	0.10~0.35	200~350	0.03~0.25		200~300	0.05~0.30	150~300	0.10~0.35	
	PC3500	200~300	0.05~0.30	150~300	0.10~0.35	200~350	0.03~0.25		200~300	0.05~0.30	150~300	0.10~0.35	
K	PC6510	150~300	0.08~0.35	150~300	0.10~0.40	-	-	RM8E 9.0мм	150~300	0.08~0.35	150~300	0.10~0.40	RM8E 11мм
	PC5300	150~300	0.08~0.35	150~300	0.10~0.40	-	-		150~300	0.08~0.35	150~300	0.10~0.40	
M	PC9530	100~180	0.05~0.30	120~180	0.10~0.35	120~200	0.03~0.2	RM8Q 11.5мм	-	-	-	-	RM8Q 11.5мм
	PC5300	-	-	-	-	-	-		100~180	0.05~0.30	120~180	0.10~0.35	

Rich Mill RMH8

Система крепления винтом

- ▶ Простота и высокая эксплуатационная надежность системы крепления

Высокая жесткость и эксплуатационная надежность системы крепления СМП

- ▶ Наличие опорной пластины позволяет предотвратить разрушение посадочного гнезда СМП в случае поломки СМП

Применение опорной пластины

- ▶ Широкая номенклатура выпускаемых фрез с различными углами в плане: 45, 75, 80
- ▶ Высокая надежность крепления опорной пластины и СМП

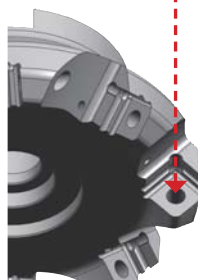
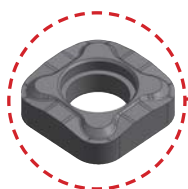
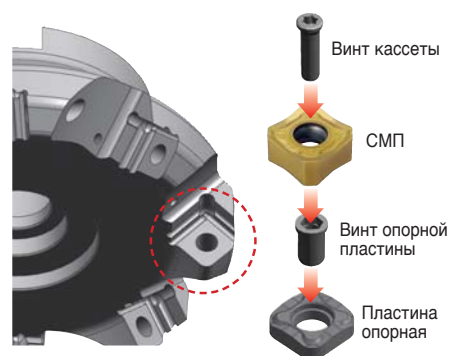

RMH8A
(AA 45°)

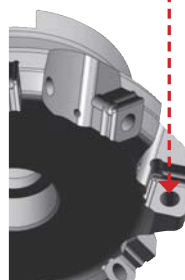

RMH8E
(AA 75°)

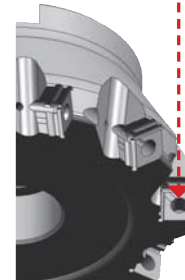

RMH8Q
(AA 88°)

Rich Mill RM16

- Свойства**
- ▶ Высокая экономичность применения за счет 16 режущих кромок на одной СМП.
 - ▶ Возможность использования СМП Wiper для получения низкой шероховатости поверхности.
 - ▶ Оптимальная геометрия на основе новой марки твердого сплава обеспечивает высокую стойкость и эффективность фрезирования.
 - ▶ При использовании СМП с 16 рабочими кромками максимальная глубина резания составит 5,5 мм. В случае применения СМП с 8 рабочими кромками максимальная глубина резания увеличится до 13 мм.
 - ▶ Режущая кромка СМП «Wiper» устанавливается на 0,05 мм ниже уровня остальных СМП.
 - ▶ Если величина подачи численно превышает размер режущей кромки (7 мм), то в корпус фрезы симметрично устанавливают 2 СМП «Wiper».



Общие характеристики и применение

СМП	Режущая кромка	Общие характеристики
Для алюминия МА		Снижение сил резания за счет положительной геометрии передней поверхности. Препятствие наростообразованию. Высокое качество обработки.
Чистовое точение MF		Специальная геометрия передней поверхности для обработки вязких материалов: нержавеющей сталей, марганцовистых сталей и т.д.
Универсальное точение MM		Применение в широком диапазоне режимов резания при обеспечении высокой стойкости СМП.
Wiper W		Уменьшение шероховатости поверхности по сравнению с применением стружколомов MM и MF.

Инструкция по установке пластин Wiper

направление	Правильная установка	Не правильная установка				
Правое исполнение						
	○	x	x	x	x	x
Левое исполнение						
	○	x	x	x	x	x

Система охлаждения

- Большая стружечная канавка препятствует пакетированию стружки.
- Использование системы охлаждения уменьшает температуру в зоне резания и обеспечивает хороший отвод стружки.



Рекомендуемые режимы резания

ISO	Марка сплава	ONM(H)X060608-MM		ONM(H)X060608-MF		ONHX060608-W		ONM(H)X080608-MM		ONM(H)X080608-MF		ONHX080608-W	
		V(м/мин)	Sz(мм/зуб)	V(м/мин)	Sz(мм/зуб)	V(м/мин)	Sz(мм/зуб)	V(м/мин)	Sz(мм/зуб)	V(м/мин)	Sz(мм/зуб)	V(м/мин)	Sz(мм/зуб)
P	NCM325	150~300	0.10~0.35	200~300	0.05~0.30	200~300	0.05~0.20	150~300	0.10~0.40	200~300	0.05~0.35	200~300	0.05~0.25
	PC3500	150~300	0.10~0.35	200~300	0.05~0.30	200~300	0.05~0.20	150~300	0.10~0.40	200~300	0.05~0.35	200~300	0.05~0.25
M	PC9530	120~180	0.10~0.35	100~180	0.05~0.30	100~180	0.05~0.20	120~180	0.10~0.40	100~180	0.05~0.35	100~180	0.05~0.25
K	PC6510	150~300	0.10~0.40	150~300	0.08~0.35	150~300	0.05~0.25	150~300	0.10~0.45	150~300	0.08~0.40	150~300	0.05~0.30

Rich Mill RMT8

Общие характеристики

- ▶ Новая система крепления обеспечивает простоту установки и закрепления.
- ▶ СМП, изготовленные из новых материалов, обладают высокой стойкостью и позволяют получить хорошее качество поверхности при обработке.
- ▶ Стружколомы MF и MM применимы в самых различных условиях резания.
- ▶ Функциональные возможности фрез RMT позволяют заменить стандартные фрезы.

Особенности фрез RMT

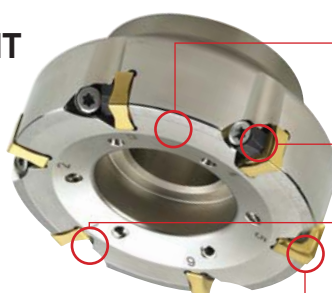

- Жесткая конструкция корпуса обеспечивает высокую эксплуатационную надежность.
- Новая система крепления обеспечивает простую и быструю замену СМП.
- Специальные стружечные канавки обеспечивают стабильный отвод стружки из зоны резания.
- Экономичное применение пластин с 8 режущими кромками.



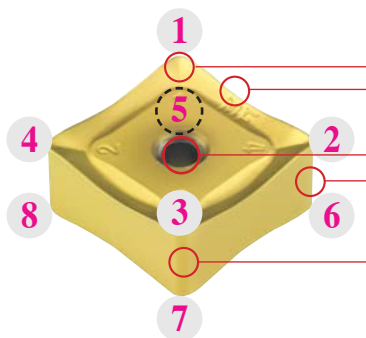

Общие характеристики СМП для фрез RMTR/L) Анализ системы крепления методом конечных элементов

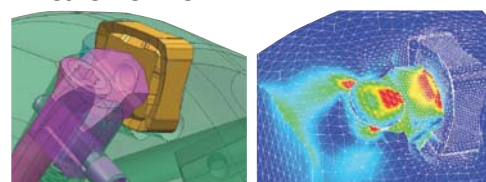

- 1 8 режущих кромок
- 2 Низкие силы резания за счет большого переднего угла стружколома.
- 3 Отверстие для закрепления.
- 4 Высокая износостойкость покрытия.
- 5 Оптимальная геометрия вспомогательных кромок позволяет применять пластины для правого и левого исполнения фрез и получать высокое качество обработанной поверхности.
- 6
- 7
- 8

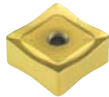

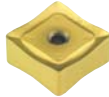
Рекомендации по выбору стружколомов

СМП	Режущая кромка	Общие характеристики
Чистовое фрезирование MF 		Специальная геометрия способствует снижению сил резания и обеспечивает высокое качество чистовой обработки
Универсальное применение MM 		Усиленна режущая кромка, универсальное применение

Рекомендации по выбору марок сплава и стружколомов Рекомендуемые режимы резания

ISO	Марка сплава	MM	MF
P	NCM325		○
	PC3500		○
	PC3545		○
M	PC9530		◎
K	PC6510		◎

ISO	Марка сплава	MM		MF	
		V(м/мин)	Sz(мм/зуб)	V(м/мин)	Sz(мм/зуб)
P	NCM325	150~300	0.05~0.30	150~300	0.05~0.20
	PC3500	150~300	0.05~0.30	150~300	0.05~0.20
	PC3545	150~300	0.05~0.30	150~300	0.05~0.20
M	PC9530	120~180	0.05~0.20	120~180	0.05~0.20
K	PC6510	150~300	0.05~0.30	150~300	0.05~0.20

◎ : оптимальный ○ : надлежащий

Общий вид	Диаметр фрезы, мм	Угол в плане	Обозначение		Общие характеристики	Стр.		
RM8A RM8AC4000 (RM8ACM) RM8AC5000 (RM8ACM) RMH8A RMH8AC4000 (RMH8ACM) <i>New</i> RMH8AC5000 (RMH8ACM)		Ø50~Ø400 Ø80~Ø400	45°	SNEX1206ANN-MF SNMX1206ANN-MF SNEX1206ANN-MM SNMX1206ANN-MM SNEX1206ANN-MA	SNEX1206ANN-W SNEX1507ANN-MF SNMX1507ANN-MF SNEX1507ANN-MM SNMX1507ANN-MM		E60 E61 E62 E63	
RM8E RM8EC4000 (RM8ECM) RM8EC5000 (RM8ECM) RMH8E RMH8EC4000 (RMH8ECM) <i>New</i> RMH8EC5000 (RMH8ECM)		Ø50~Ø400 Ø80~Ø400	75°	SNEX1206ENN-MF SNMX1206ENN-MF SNEX1206ENN-MM SNMX1206ENN-MM SNEX1206ENN-MA	SNEX1507ENN-MF SNMX1507ENN-MF SNEX1507ENN-MM SNMX1507ENN-MM		<ul style="list-style-type: none"> • Экономичность применения, 8 режущих кромок • Снижение сил резания за счет положительной геометрии стружколома 	E64 E65 E66 E67
RM8Q RM8QC4000 (RM8QCM) RMH8Q RMH8QC4000 (RMH8QCM)		Ø63~Ø200 Ø80~Ø200	88°	SNEX1206QNN-MF SNMX1206QNN-MF SNEX1206QNN-MM SNMX1206QNN-MM SNEX1206QNN-MA	SNEX120612-MF SNMX120612-MF SNEX120612-MM SNMX120612-MM SNEX120612-MA		E68 E69	
RM16AC RM16AC6000 RM16AC8000 (RM16ACM)		Ø63~Ø400	45°	ONHX060608-MF / MM ONMX060608-MF / MM ONHX0606ANN-MF / MM ONMX0606ANN-MF / MM ONHX080608-MF / MM ONMX080608-MF / MM	ONHX0806ANN-MF / MM ONMX0806ANN-MF / MM ONHX060608-MA ONMX060608-W ONHX080608-MA ONMX080608-W		<ul style="list-style-type: none"> • Экономичность применения, 16 режущих кромок • Повышение качества обработки за счет применения СМП типа «Wiper» 	E70 E71
RMT8A RMT8A4000 RMT8A5000 (RMT8AM)		Ø80~Ø315	45°	SNCF1206ANN-MF / MM SNCF1507ANN-MF / MM SNMF1206ANN-MF / MM SNMF1507ANN-MF / MM			E72 E73	
RMT8E RMT8E4000 RMT8E5000 (RMT8EM)		Ø80~Ø315	75°	SNCF1206ENN-MF / MM SNCF1507ENN-MF / MM SNMF1206ENN-MF / MM SNMF1507ENN-MF / MM			<ul style="list-style-type: none"> • Экономичность применения, 8 режущих кромок • Снижение сил резания за счет положительной геометрии передней поверхности • Высокая устойчивость к выкрашиванию режущих кромок 	E74 E75
RMT8Q (RMT8QM)		Ø80~Ø315	88°	SNCF1206QNN-MF SNMF1206QNN-MF			E76	



RM8AC(M)4000



Рис. 1



Рис. 2

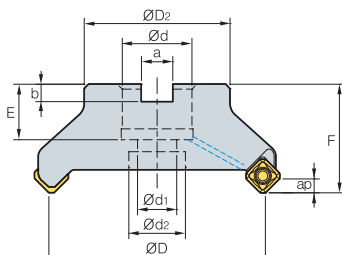

• AR : -6°
• RR : -9°~6°

(мм)

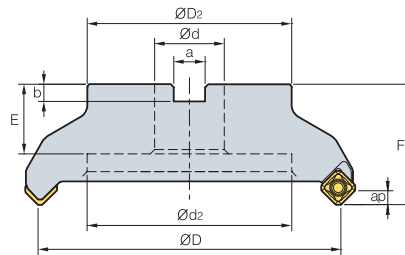
Обозначение		$\varnothing D$	$\varnothing D_2$	$\varnothing d$	$\varnothing d_1$	$\varnothing d_2$	a	b	E	F	ap		Рис.		
RM8ACM		4050HR-M	4	50	49	22	11	18	10.4	6.3	20	40	6.0	0.5	1
		4050HR-H	6	50	49	22	11	18	10.4	6.3	20	40	6.0	0.5	1
		4063HR-M	6	63	49	22	11	18	10.4	6.3	20	40	6.0	0.7	1
		4063HR-H	8	63	49	22	11	18	10.4	6.3	20	40	6.0	0.7	1
RM8AC		4080HR	5	80	57	25.4(27)	14	20	9.5(12.4)	6(7)	25(23)	50	6.0	1.2	1
(RM8ACM)		4080HR-M	7	80	57	25.4(27)	14	20	9.5(12.4)	6(7)	25(23)	50	6.0	1.2	1
		4080HR-H	10	80	57	25.4(27)	14	20	9.5(12.4)	6(7)	25(23)	50	6.0	1.3	1
		4100HR	6	100	67	31.75(32)	18	26	12.7(14.4)	8	33(25.5)	63(50)	6.0	1.7	1
		4100HR-M	8	100	67	31.75(32)	18	26	12.7(14.4)	8	33(25.5)	63(50)	6.0	1.7	1
		4100HR-H	12	100	67	31.75(32)	18	26	12.7(14.4)	8	33(25.5)	63(50)	6.0	1.7	1
		4125HR	8	125	87	38.1(40)	22	32	15.9(16.4)	10(9)	36(30)	63	6.0	3.6	1
		4125HR-M	10	125	87	38.1(40)	22	32	15.9(16.4)	10(9)	36(30)	63	6.0	3.6	1
		4125HR-H	16	125	87	38.1(40)	22	32	15.9(16.4)	10(9)	36(30)	63	6.0	3.7	1
		4160R	10	160	107	50.8(40)	-	107	19(16.4)	11(9)	38(32)	63	6.0	4.8	2
		4160R-M	12	160	107	50.8(40)	-	107	19(16.4)	11(9)	38(32)	63	6.0	5.3	2
		4160R-H	20	160	107	50.8(40)	-	107	19(16.4)	11(9)	38(32)	63	6.0	5.4	2
		4200R-M	14	200	130	47.625(60)	-	135	25.4(25.7)	14	38(32)	63	6.0	7.1	2
		4200R-H	24	200	130	47.625(60)	-	135	25.4(25.7)	14	38(32)	63	6.0	7.1	2
		4250R-M	16	250	180	47.625(60)	-	180	25.4(25.7)	14	38(32)	63	6.0	11.9	2
		4250R-H	30	250	180	47.625(60)	-	180	25.4(25.7)	14	38(32)	63	6.0	12.0	2
		4315R	18	315	240	47.625(60)	-	238	25.4(25.7)	14	38	63	6.0	18.8(18.6)	2
		4315R-M	20	315	240	47.625(60)	-	238	25.4(25.7)	14	38	63	6.0	18.8(18.6)	2
		4400R-M	28	400	260	47.625(60)	-	238	25.4(25.7)	14	38	80	6.0	37.7(37.4)	2

• () Метрическая система

Применяемые СМП

SNEX-MF SNEX-MM SNEX-MA SNEX-W SNMX-MF SNMX-MM



Обозначение	Тв. сплав с покрытием			Кермет		Тв. сплав		Стр.
	NCM825	NCM835	NCM830	PC3500	PC5400	PC9530	PC9545	
SNEX 1206ANN-MF								E19
1206ANN-MM	●	●	●	●	●	●	●	
SNMX 1206ANN-MF								E19
1206ANN-MM	●	●	●	●	●	●	●	
SNEX 1206ANN-MA							●	
1206ANN-W				●				

Применяемые оправки

Обозначение	Применяемые оправки	
	RM8AC	RM8ACM
RM8ACM 4050HR-□	-	BT□□-FMC22-□□
4063HR-□		
RM8AC 4080HR-□	BT□□-FMA25.4-□□	BT□□-FMC27-□□
(RM8ACM) 4100HR-□	BT□□-FMA31.75-□□	BT□□-FMC32-□□
4125HR-□	BT□□-FMA38.1-□□	BT□□-FMB40-□□
4160R-□	BT□□-FMA50.8-□□	BT□□-FMC40-□□
4200R-□		
4250R-□	BT□□-FMA47.625-□□	BT□□-FMB60-□□
4315R-□		
4400R-□		

Комплектующие

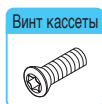

FTKA0410

TW15S

RMH8AC(M)4000 *New*

Пластина опорная Тип



Рис. 1



Рис. 2

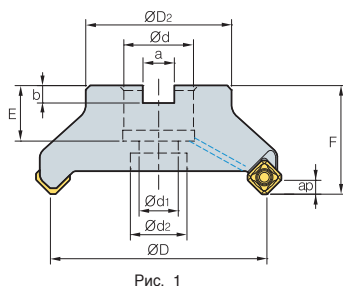

• AR : -6°
• RR : -9°~6°

(мм)

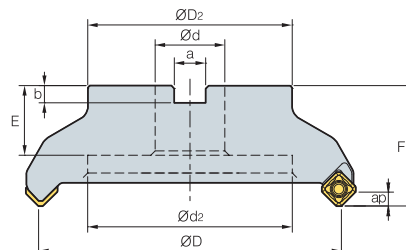
Обозначение		$\varnothing D$	$\varnothing D_2$	$\varnothing d$	$\varnothing d_1$	$\varnothing d_2$	a	b	E	F	ap		Рис.	
RMH8AC 4080HR-M		7	80	57	25.4(27)	14	20	9.5(12.4)	6(7)	25(23)	50	6.0	1.2	1
(RMH8ACM) 4100HR-M		8	100	67	31.75(32)	18	26	12.7(14.4)	8	33(25.5)	63(50)	6.0	1.7	1
4125HR-M		10	125	87	38.1(40)	22	32	15.9(16.4)	10(9)	36(30)	63	6.0	3.6	1
4160R-M		12	160	107	50.8(40)	-	107	19(16.4)	11(9)	38(32)	63	6.0	5.3	2
4200R-M		14	200	130	47.625(60)	-	135	25.4(25.7)	14	38(32)	63	6.0	7.1	2
4250R-M		16	250	180	47.625(60)	-	180	25.4(25.7)	14	38(32)	63	6.0	11.9	2
4315R-M		20	315	240	47.625(60)	-	238	25.4(25.7)	14	38	63	6.0	18.8(18.6)	2
4400R-M		26	400	260	47.625(60)	-	238	25.4(25.7)	14	38	80	6.0	37.7(37.4)	2

• () Метрическая система

Применяемые СМП

	SNEX-MF	SNEX-MM	SNEX-MA	SNEX-W	SNMX-MF	SNMX-MM												
Обозначение	Тв. сплав с покрытием								Кермет			Тв. сплав		Стр.				
	NCM325	NCM335	NC5330	PC3500	PC5300	PC5400	PC3545	PC9530	PC6510	PD2000	CN2000	CN20	CN30		H01	G10	ST30A	ST20
SNEX 1206ANN-MF				●	●	●			●									
1206ANN-MM	●			●	●	●			●									
SNMX 1206ANN-MF				●	●				●									
1206ANN-MM	●		●	●	●				●									
SNEX 1206ANN-MA														●				
1206ANN-W				●					●									

Применяемые оправки

Обозначение	Применяемые оправки	
	RMH8AC	RMH8ACM
RMH8AC 4080HR-□	BT□□-FMA25.4-□□	BT□□-FMC27-□□
(RMH8ACM) 4100HR-□	BT□□-FMA31.75-□□	BT□□-FMC32-□□
4125HR-□	BT□□-FMA38.1-□□	BT□□-FMB40-□□
4160R-□	BT□□-FMA50.8-□□	BT□□-FMC40-□□
4200R-□		
4250R-□		
4315R-□	BT□□-FMA47.625-□□	BT□□-FMB60-□□
4400R-□		

Комплектующие

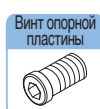

FTKA0412B

SS42RM8

SHXN0609F

TW15S

RM8AC(M)5000



Рис. 1



Рис. 2

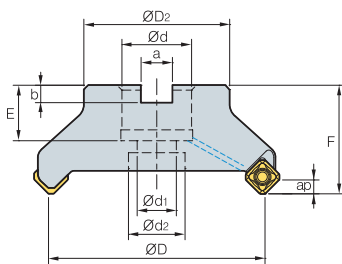
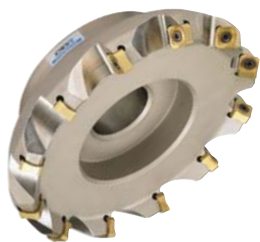

• AR : -6°
• RR : -9°~6°

(мм)

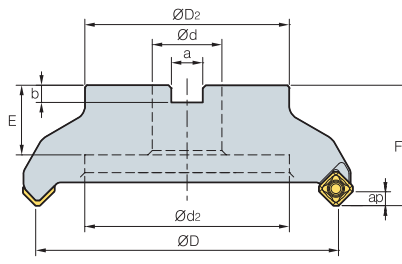
Обозначение		$\varnothing D$	$\varnothing D_2$	$\varnothing d$	$\varnothing d_1$	$\varnothing d_2$	a	b	E	F	ap		Рис.	
RM8AC	5080HR-M	6	80	57	25.4(27)	14	20	9.5(12.4)	6(7)	25(23)	50	7.5	1.2	1
(RM8ACM)	5100HR-M	7	100	67	31.75(32)	18	26	12.7(14.4)	8.0	33(25)	63(50)	7.5	2.5(1.8)	1
	5125HR-M	8	125	87	38.1(40)	22	32	15.9(16.4)	10(9)	35(30)	63	7.5	3.6	1
	5160R-M	10	160	107	50.8(40)	-	107	19(16.4)	11(9)	38(32)	63	7.5	5(4.56)	2
	5200R-M	12	200	130	47.625(60)	-	135	25.4(25.7)	14.0	38	63	7.5	7.1(6.8)	2
	5250R-M	15	250	180	47.625(60)	-	180	25.4(25.7)	14.0	38	63	7.5	11.9(10.6)	2
	5315R-M	20	315	240	47.625(60)	-	238	25.4(25.7)	14.0	38	63	7.5	19.1(18.9)	2
	5400R-M	28	400	260	47.625(60)	-	238	25.4(25.7)	14.0	38	80	7.5	37.7(37.5)	2

• () Метрическая система

Применяемые СМП

SNEX-MF

SNEX-MM

SNEX-MA

SNMX-MF

SNMX-MM



Обозначение	Тв. сплав с покрытием									Кермет			Тв. сплав				Стр.
	NCM325	NCM335	NC5330	PC3500	PC5300	PC3545	PC9530	PC6510	PC215K	PD2000	CN2000	CN20	CN30	H01	G10	ST30A	
SNEX 1507ANN-MF				●				●									
1507ANN-MM				●				●									
SNMX 1507ANN-MF				●				●									
1507ANN-MM				●				●									

E19

Применяемые оправки

Обозначение	Применяемые оправки	
	RM8AC	RM8ACM
RM8AC 5080HR-□	BT□□-FMA25.4-□□	BT□□-FMC27-□□
(RM8ACM) 5100HR-□	BT□□-FMA31.75-□□	BT□□-FMC32-□□
5125HR-□	BT□□-FMA38.1-□□	BT□□-FMB40-□□
5160R-□	BT□□-FMA50.8-□□	BT□□-FMC40-□□
5200R-□		
5250R-□	BT□□-FMA47.625-□□	BT□□-FMB60-□□
5315R-□		
5400R-□		

Комплектующие

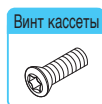

Винт кассеты



Ключ

FTGA0513

TW20-100



RMH8AC(M)5000 *New*

Пластина опорная Тип



Рис. 1



Рис. 2

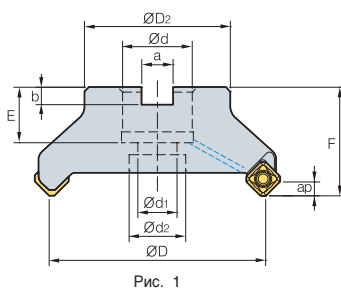

• AR : -6°
• RR : -9°~6°

(мм)

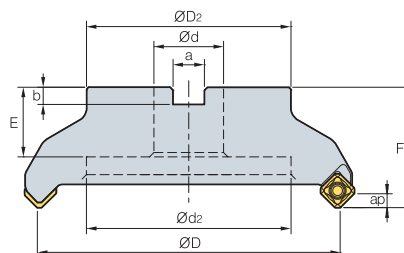
Обозначение		ØD	ØD2	Ød	Ød1	Ød2	a	b	E	F	ap		Рис.	
RMH8AC 5080HR-M		6	80	57	25.4(27)	14	20	9.5(12.4)	6(7)	25(23)	50	7.5	1.2	1
(RMH8ACM) 5100HR-M		7	100	67	31.75(32)	18	26	12.7(14.4)	8.0	33(25)	63(50)	7.5	2.5(1.8)	1
5125HR-M		8	125	87	38.1(40)	22	32	15.9(16.4)	10(9)	36(30)	63	7.5	3.6	1
5160R-M		10	160	107	50.8(40)	-	107	19(16.4)	11(9)	38(32)	63	7.5	5(4.56)	2
5200R-M		12	200	130	47.625(60)	-	135	25.4(25.7)	14.0	38(32)	63	7.5	7.1(6.8)	2
5250R-M		15	250	180	47.625(60)	-	180	25.4(25.7)	14.0	38(32)	63	7.5	11.9(10.6)	2
5315R-M		20	315	240	47.625(60)	-	238	25.4(25.7)	14.0	38	63	7.5	19.1(18.9)	2
5400R-M		22	400	260	47.625(60)	-	238	25.4(25.7)	14.0	38	80	7.5	37.7(37.5)	2

• () Метрическая система

Применяемые СМП

	SNEX-MF	SNEX-MM	SNEX-MA	SNMX-MF	SNMX-MM													
Обозначение	Тв. сплав с покрытием								Кермет			Тв. сплав		Стр.				
	NCM325	NCM335	NC5330	PC3500	PC5300	PC3545	PC9530	PC6510	PC215K	PD2000	CN2000	CN20	CN30		H01	G10	ST30A	ST20
SNEX 1507ANN-MF								●										E19
1507ANN-MM				●				●										
SNMX 1507ANN-MF				●				●										
1507ANN-MM																		

Применяемые оправки

Обозначение	Применяемые оправки	
	RMH8AC	RMH8ACM
RMH8AC 5080HR-□	BT□□-FMA25.4-□□	BT□□-FMC27-□□
(RMH8ACM) 5100HR-□	BT□□-FMA31.75-□□	BT□□-FMC32-□□
5125HR-□	BT□□-FMA38.1-□□	BT□□-FMB40-□□
5160R-□	BT□□-FMA50.8-□□	BT□□-FMC40-□□
5200R-□		
5250R-□	BT□□-FMA47.625-□□	BT□□-FMB60-□□
5315R-□		
5400R-□		

Комплектующие

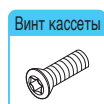

FTGA0513

SS53RM8

SHXN0712F

TW20-100

RM8EC(M)4000



Рис. 1



Рис. 2

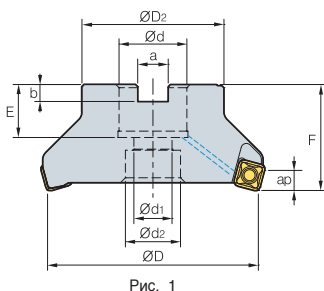

• AR : -6°
• RR : -8°~6°

(MM)

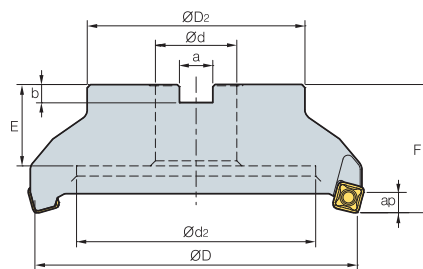
Обозначение		$\varnothing D$	$\varnothing D_2$	$\varnothing d$	$\varnothing d_1$	$\varnothing d_2$	a	b	E	F	ap		Рис.	
RM8EC	4050HR-M	4	50	49	22	11	18	10.4	6.3	20	40	9.0	0.4	1
(RM8ECM)	4063HR-M	6	63	49	22	11	18	10.4	6.3	20	40	9.0	0.6	1
	4080HR	5	80	57	25.4(27)	14	20	9.5(12.4)	6(7)	25(23)	50	9.0	1.2	1
	4080HR-M	7	80	57	25.4(27)	14	20	9.5(12.4)	6(7)	25(23)	50	9.0	1.1	1
	4100HR	6	100	67	31.75(32)	18	26	12.7(14.4)	8	33(25)	63(50)	9.0	1.6	1
	4100HR-M	8	100	67	31.75(32)	18	26	12.7(14.4)	8	33(25)	63(50)	9.0	2.5	1
	4125HR	8	125	87	38.1(40)	22	32	15.9(16.4)	10(9)	35(29)	63	9.0	2.9(3.3)	1
	4125HR-M	10	125	87	38.1(40)	22	32	15.9(16.4)	10(9)	35(29)	63	9.0	3.0	1
	4160R	10	160	107	50.8(40)	-	107	19(16.4)	11(9)	38(32)	63	9.0	4.4	2
	4160R-M	12	160	107	50.8(40)	-	107	19(16.4)	11(9)	38(32)	63	9.0	4.0	2
	4200R-M	16	200	130	47.625(60)	-	135	25.4(25.7)	14	38(32)	63	9.0	5.9	2
	4250R-M	16	250	180	47.625(60)	-	180	25.4(25.7)	14	38	63	9.0	10.9(10.6)	2
	4315R-M	20	315	240	47.625(60)	-	238	25.4(25.7)	14	38	63	9.0	18.1(17.9)	2
	4400R-M	28	400	260	47.625(60)	-	238	25.4(25.7)	14	38	80	9.0	31.8(31.5)	2

• () Метрическая система

Применяемые СМП

SNEX-MF SNEX-MM SNEX-MA SNMX-MF SNMX-MM



Обозначение	Тв. сплав с покрытием				Кермет			Тв. сплав		Стр.			
	NCM325	NCM335	PC3500	PC3500	PC3545	PC9530	PD2000	CN2000	CN30		H01	G10	ST30A
SNEX 1206ENN-MF			•	•	•								
1206ENN-MM			•	•	•								
SNMX 1206ENN-MF			•	•	•								
1206ENN-MM			•	•	•								
SNEX 1206ENN-MA			•		•					•			

Применяемые оправки

Обозначение	Применяемые оправки	
	RM8EC	RM8ECM
RM8ECM 4050HR-□	-	BT□□-FMC22-□□
4063HR-□		
RM8EC 4080HR-□	BT□□-FMA25.4-□□	BT□□-FMC27-□□
(RM8ECM) 4100HR-□	BT□□-FMA31.75-□□	BT□□-FMC32-□□
4125HR-□	BT□□-FMA38.1-□□	BT□□-FMB40-□□
4160R-□	BT□□-FMA50.8-□□	BT□□-FMC40-□□
4200R-□		
4250R-□	BT□□-FMA47.625-□□	BT□□-FMB60-□□
4315R-□		
4400R-□		

Комплектующие

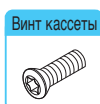

PTKA0411-R3

TW15S

RMH8EC(M)4000

New

Пластина опорная Тип



Рис. 1



Рис. 2

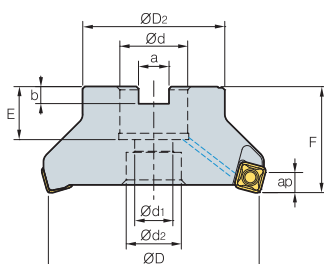

• AR : -6°
• RR : -8°~6°

(мм)

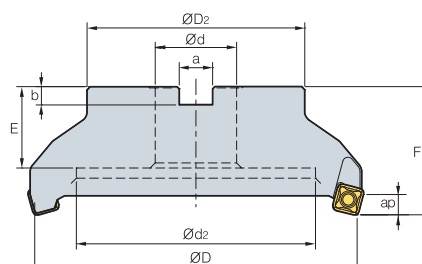
Обозначение		$\varnothing D$	$\varnothing D_2$	$\varnothing d$	$\varnothing d_1$	$\varnothing d_2$	a	b	E	F	ap		Рис.	
RMH8EC 4080HR-M		7	80	57	25.4(27)	14	20	9.5(12.4)	6(7)	25(23)	50	9.0	1.1	1
(RMH8ECM) 4100HR-M		8	100	67	31.75(32)	18	26	12.7(14.4)	8	33(25.5)	63(50)	9.0	2.5	1
4125HR-M		10	125	87	38.1(40)	22	32	15.9(16.4)	10(9)	36(30)	63	9.0	3.0	1
4160R-M		12	160	107	50.8(40)	-	107	19(16.4)	11(9)	38(32)	63	9.0	4.0	2
4200R-M		16	200	130	47.625(60)	-	135	25.4(25.7)	14	38(32)	63	9.0	5.9	2
4250R-M		16	250	180	47.625(60)	-	180	25.4(25.7)	14	38(32)	63	9.0	10.9(10.6)	2
4315R-M		20	315	240	47.625(60)	-	238	25.4(25.7)	14	38	63	9.0	18.1(17.9)	2
4400R-M		24	400	260	47.625(60)	-	238	25.4(25.7)	14	38	80	9.0	31.8(31.5)	2

• () Метрическая система

Применяемые СМП

	SNEX-MF	SNEX-MM	SNEX-MA	SNMX-MF	SNMX-MM													
Обозначение	Тв. сплав с покрытием								Кермет			Тв. сплав				Стр.		
	NCM325	NCM335	NC5330	PC3500	PC5300	PC5400	PC3545	PC9530	PC6510	PD2000	CN2000	CN20	CN30	H01	G10		ST30A	ST20
SNEX 1206ENN-MF					●	●			●									E19
1206ENN-MM				●	●	●			●									
SNMX 1206ENN-MF				●	●	●			●									
1206ENN-MM				●	●	●			●									
SNEX 1206ENN-MA				●					●				●					

Применяемые оправки

Обозначение	Применяемые оправки	
	RMH8EC	RMH8ECM
RMH8AC 4080HR-□	BT□□-FMA25.4-□□	BT□□-FMC27-□□
(RMH8ACM) 4100HR-□	BT□□-FMA31.75-□□	BT□□-FMC32-□□
4125HR-□	BT□□-FMA38.1-□□	BT□□-FMB40-□□
4160R-□	BT□□-FMA50.8-□□	BT□□-FMC40-□□
4200R-□		
4250R-□	BT□□-FMA47.625-□□	BT□□-FMB60-□□
4315R-□		
4400R-□		

Комплектующие

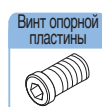
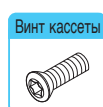

PTKA0411-R3

SS42RM8

SHXN0609F

TW15S

RM8EC(M)5000



Рис. 1



Рис. 2

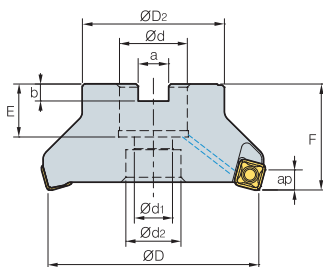

• AR : -6°
• RR : -8°~6°

(мм)

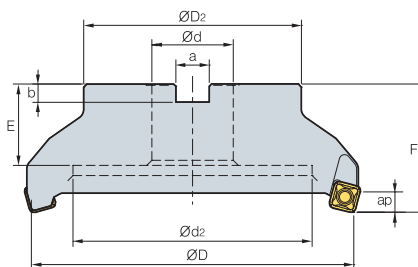
Обозначение		$\varnothing D$	$\varnothing D_2$	$\varnothing d$	$\varnothing d_1$	$\varnothing d_2$	a	b	E	F	ap		Рис.
RM8EC 5080HR-M	6	80	57	25.4(27)	14	20	9.5(12.4)	6(7)	25(23)	50	11.0	1.1	1
(RM8ECM) 5100HR-M	7	100	67	31.75(32)	18	26	12.7(14.4)	8.0	33(25)	63(50)	11.0	2.1(1.7)	1
5125HR-M	8	125	87	38.1(40)	22	32	15.9(16.4)	10(9)	35(30)	63	11.0	3.4(3.3)	1
5160R-M	10	160	107	50.8(40)	-	107	19(16.4)	11(9)	38(32)	63	11.0	4.4(4.1)	2
5200R-M	12	200	130	47.625(60)	-	135	25.4(25.7)	14.0	38	63	11.0	6.4(6.1)	2
5250R-M	15	250	180	47.625(60)	-	180	25.4(25.7)	14.0	38	63	11.0	11.0(10.7)	2
5315R-M	20	315	240	47.625(60)	-	238	25.4(25.7)	14.0	38	63	11.0	18.0(17.7)	2
5400R-M	28	400	260	47.625(60)	-	238	25.4(25.7)	14.0	38	80	11.0	35.7(35.4)	2

• () Метрическая система

Применяемые СМП

SNEX-MF

SNEX-MM

SNEX-MA

SNMX-MF

SNMX-MM

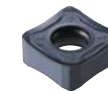
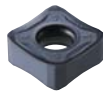

Обозначение	Тв. сплав с покрытием									Кермет			Тв. сплав				Стр.
	NCM325	NCM335	NC5330	PC3500	PC5300	PC3545	PC9530	PC6510	PC215K	PD2000	CN2000	CN20	CN30	H01	G10	ST30A	
SNEX 1507ENN-MF				●				●									
1507ENN-MM				●				●									
SNMX 1507ENN-MF				●				●									
1507ENN-MM				●				●									

Применяемые оправки

Обозначение	Применяемые оправки	
	RM8EC	RM8ECM
RM8EC 5080HR-□	BT□□-FMA25.4-□□	BT□□-FMC27-□□
(RM8ECM) 5100HR-□	BT□□-FMA31.75-□□	BT□□-FMC32-□□
5125HR-□	BT□□-FMA38.1-□□	BT□□-FMB40-□□
5160R-□	BT□□-FMA50.8-□□	BT□□-FMC40-□□
5200R-□		
5250R-□	BT□□-FMA47.625-□□	BT□□-FMB60-□□
5315R-□		
5400R-□		

Комплектующие

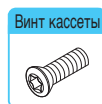

Винт кассеты



Ключ

FTGA0513

TW20-100



RMH8EC(M)5000 *New*

Пластина опорная Тип



Рис. 1



Рис. 2

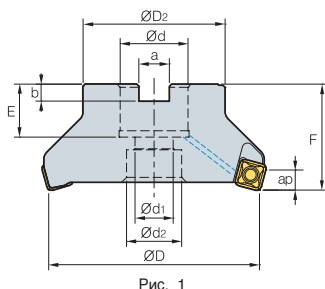

• AR : -6°
• RR : -8°~6°

(мм)

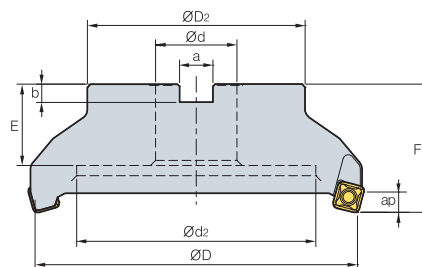
Обозначение		ØD	ØD2	Ød	Ød1	Ød2	a	b	E	F	ap		Рис.	
RMH8EC 5080HR-M		6	80	57	25.4(27)	14	20	9.5(12.4)	6(7)	25(23)	50	11.0	1.1	1
(RMH8ECM) 5100HR-M		7	100	67	31.75(32)	18	26	12.7(14.4)	8.0	33(25.5)	63(50)	11.0	2.1(1.7)	1
5125HR-M		8	125	87	38.1(40)	22	32	15.9(16.4)	10(9)	36(30)	63	11.0	3.4(3.3)	1
5160R-M		10	160	107	50.8(40)	-	107	19(16.4)	11(9)	38(32)	63	11.0	4.4(4.1)	2
5200R-M		12	200	130	47.625(60)	-	135	25.4(25.7)	14.0	38(32)	63	11.0	6.4(6.1)	2
5250R-M		15	250	180	47.625(60)	-	180	25.4(25.7)	14.0	38(32)	63	11.0	11.0(10.7)	2
5315R-M		20	315	240	47.625(60)	-	238	25.4(25.7)	14.0	38	63	11.0	18.0(17.7)	2
5400R-M		22	400	260	47.625(60)	-	238	25.4(25.7)	14.0	38	80	11.0	35.7(35.4)	2

• () Метрическая система

Применяемые СМП

	SNEX-MF	SNEX-MM	SNEX-MA	SNMX-MF	SNMX-MM													
Обозначение	Тв. сплав с покрытием								Кермет			Тв. сплав		Стр.				
	NCM325	NCM335	NC5330	PC3500	PC5300	PC5445	PC9530	PC6510	PC215K	PD2000	CN2000	CN20	CN30		H01	G10	ST30A	ST20
SNEX 1507ENN-MF				●														E19
1507ENN-MM				●														
SNMX 1507ENN-MF				●														
1507ENN-MM				●														

Применяемые оправки

Обозначение	Применяемые оправки	
	RMH8EC	RMH8ECM
RMH8EC 5080HR-□	BT□□-FMA25.4-□□	BT□□-FMC27-□□
(RMH8ECM) 5100HR-□	BT□□-FMA31.75-□□	BT□□-FMC32-□□
5125HR-□	BT□□-FMA38.1-□□	BT□□-FMB40-□□
5160R-□	BT□□-FMA50.8-□□	BT□□-FMC40-□□
5200R-□		
5250R-□	BT□□-FMA47.625-□□	BT□□-FMB60-□□
5315R-□		
5400R-□		

Комплектующие

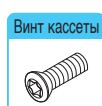

FTGA0513

SS53RM8

SHXN0712F

TW20-100

RM8QC(M)4000



Рис. 1



Рис. 2

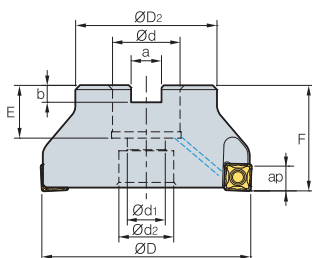

• AR : -6°
• RR : -8°~6°

(мм)

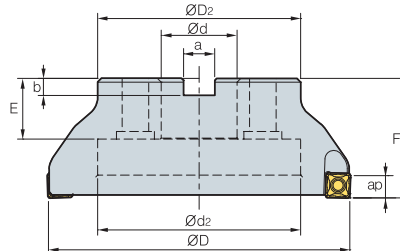
Обозначение		$\varnothing D$	$\varnothing D_2$	$\varnothing d$	$\varnothing d_1$	$\varnothing d_2$	a	b	E	F	ap		Рис.	
RM8QC	4063HR-M	6	63	49	22	11	18	10.4	6.3	20	40	11.5	0.6	1
(RM8QCM)	4063HR-H	8	63	49	22	11	18	10.4	6.3	20	40	11.5	0.6	1
	4080HR-M	7	80	57	25.4(27)	14	20	9.5(12.4)	6(7)	25(23)	50	11.5	1.1	1
	4080HR-H	10	80	57	25.4(27)	14	20	9.5(12.4)	6(7)	25(23)	50	11.5	1.0	1
	4100HR-M	8	100	67	31.75(32)	18	26	12.7(14.4)	8	33(25.5)	63(50)	11.5	1.7	1
	4100HR-H	12	100	67	31.75(32)	18	26	12.7(14.4)	8	33(25.5)	63(50)	11.5	1.6	1
	4125HR-M	10	125	87	38.1(40)	22	32	15.9(16.4)	10(9)	36(30)	63	11.5	3.3	1
	4125HR-H	14	125	87	38.1(40)	22	32	15.9(16.4)	10(9)	36(30)	63	11.5	3.3	1
	4160R-M	12	160	107	50.8(40)	-	107	19(16.4)	11(9)	38(32)	63	11.5	3.9	2
	4160R-H	20	160	107	50.8(40)	-	107	19(16.4)	11(9)	38(32)	63	11.5	3.9	2
	4200R-M	14	200	130	47.625(60)	-	135	25.4(25.7)	14	38(32)	63	11.5	6.4	2
	4200R-H	22	200	130	47.625(60)	-	135	25.4(25.7)	14	38(32)	63	11.5	6.4	2

• () Метрическая система

Применяемые СМП

SNEX-MF SNEX-MM SNEX-MA SNMX-MF SNMX-MM



Обозначение	Тв. сплав с покрытием						Кермет		Тв. сплав			Стр.			
	NCM325	NCM335	NC5330	PC3500	PC3500	PC3545	PC9530	PC9510	PD2000	CN20	CN30		H01	G10	ST30A
SNEX 1206QNN-MF				•	•	•	•								
SNMX 1206QNN-MF				•	•	•	•								
SNEX 1206QNN-MM				•	•	•	•								
SNMX 1206QNN-MM				•	•	•	•								
SNEX 1206QNN-MA															
SNEX 120612-MF															
SNMX 120612-MF															
SNEX 120612-MM															
SNMX 120612-MM				•											
SNEX 120612-MA															

Стр.

E19

Применяемые оправки

Обозначение	Применяемые оправки	
	RM8QC	RM8QCM
RM8QCM 4063HR-□	-	BT□□-FMC22-□□
4080HR-□	BT□□-FMA25.4-□□	BT□□-FMC27-□□
RM8QC 4100HR-□	BT□□-FMA31.75-□□	BT□□-FMC32-□□
(RM8QCM) 4125HR-□	BT□□-FMA38.1-□□	BT□□-FMB40-□□
4160R-□	BT□□-FMA50.8-□□	BT□□-FMC40-□□
4200R-□	BT□□-FMA47.625-□□	BT□□-FMB60-□□

Комплектующие

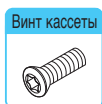

Винт кассеты



Ключ

РТКА0411-R3

TW15S



Применяемые СМП E19



Присоединительные размеры смотреть на стр. E270~E272

• : Наличие на складе

RMH8QC (M) 4000 *New*

Пластина опорная Тип



Рис. 1



Рис. 2

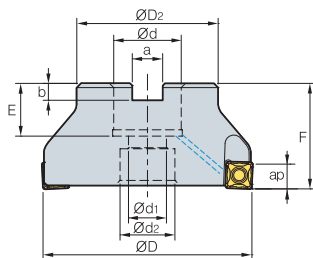

• AR : -6°
• RR : -8°~6°

													(мм)	
Обозначение		$\varnothing D$	$\varnothing D_2$	$\varnothing d$	$\varnothing d_1$	$\varnothing d_2$	a	b	E	F	ap	$\frac{R}{kg}$	Рис.	
RMH8QC 4080HR-M		7	80	57	25.4(27)	14	20	9.5(12.4)	6(7)	25(23)	50	11.5	1.1	1
(RMH8QCM) 4100HR-M		8	100	67	31.75(32)	18	26	12.7(14.4)	8	33(25.5)	63(50)	11.5	2.5	1
4125HR-M		10	125	87	38.1(40)	22	32	15.9(16.4)	10(9)	36(30)	63	11.5	3.0	1
4160R-M		12	160	107	50.8(40)	-	107	19(16.4)	11(9)	38(32)	63	11.5	4.0	2
4200R-M		16	200	130	47.625(60)	-	135	25.4(25.7)	14	38(32)	63	11.5	5.9	2

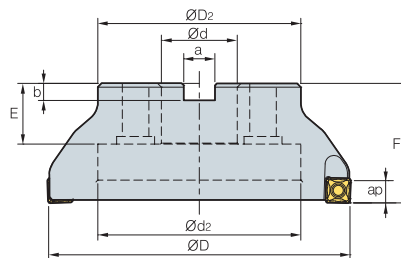
• () Метрическая система

Применяемые СМП

	SNEX-MF	SNEX-MM	SNEX-MA	SNMX-MF	SNMX-MM													
Обозначение	Тв. сплав с покрытием							Кермет			Тв. сплав				Стр.			
	NCM325	NCM335	NC5330	PC3500	PC3300	PC5400	PC3545	PC9530	PC6510	PD2000	CN2000	CN20	CN30	H01		G10	ST30A	ST20
SNEX 1206QNN-MF				•	•	•			•									E19
SNMX 1206QNN-MF				•	•	•			•									
SNEX 1206QNN-MM				•	•	•			•									
SNMX 1206QNN-MM				•	•	•			•									
SNEX 1206QNN-MA																		
SNEX 120612-MF																		
SNMX 120612-MF																		
SNEX 120612-MM																		
SNMX 120612-MM				•					•									
SNEX 120612-MA													•					

Применяемые оправки

Обозначение	Применяемые оправки	
	RMH8AC	RMH8ACM
RMH8QC 4080HR-□	BT□□-FMA25.4-□□	BT□□-FMC27-□□
(RMH8QCM) 4100HR-□	BT□□-FMA31.75-□□	BT□□-FMC32-□□
4125HR-□	BT□□-FMA38.1-□□	BT□□-FMB40-□□
4160R-□	BT□□-FMA50.8-□□	BT□□-FMC40-□□
4200R-□	BT□□-FMA47.625-□□	BT□□-FMB60-□□

Комплектующие

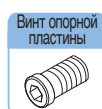
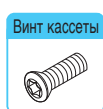

PTKA0411-R3 SS42RM8 SHXN0609F TW15S

RM16AC(M)6000

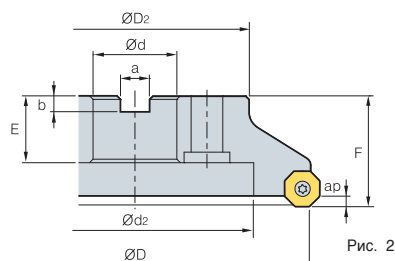
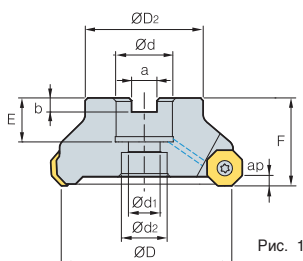

• AR : -6°
• RR : -6°

(мм)

Обозначение		ØD	ØD ₂	Ød	Ød ₁	Ød ₂	a	b	E	F	ap		Рис.
RM16AC(M) 6063HR-M	5	63	49	22	11	18	10.4	6.3	20	40	4.0	0.7	1
6080HR-M	6	80	57	25.4(27)	14	20	9.5(12.4)	6(7)	25(23)	50	4.0	1.2	1
6100HR-M	7	100	67	31.75(32)	18	26	12.7(14.4)	8	33(25)	63(50)	4.0	1.9	1
6125HR-M	8	125	87	38.1(40)	22	32	15.9(16.4)	10(9)	35(29)	63	4.0	3.5	1
6160R-M	10	160	107	50.8(40)	-	107	19(16.4)	11(9)	38(32)	63	4.0	4.1	2
6200R-M	12	200	130	47.625(60)	-	135	25.4(25.7)	14	38(32)	63	4.0	6.1	2
6250R-M	15	250	180	47.625(60)	-	180	25.4(25.7)	14	38	63	4.0	11.5	2
6315R-M	20	315	240	47.625(60)	-	238	25.4(25.7)	14	38	63	4.0	18.9	2
6400R-M	26	400	260	47.625(60)	-	238	25.4(25.7)	14	38	80	4.0	32.7	2

• () Метрическая система

Применяемые СМП

	ONHX-MF	ONHX-MM	ONHX-W	ONHX-MA	ONMX-MF	ONMX-MM											
Обозначение	Тв. сплав с покрытием								Кермет			Тв. сплав		Стр.			
	NCM325	NCM335	NC5330	PC3500	PC5300	PC5400	PC3545	PC9530	PC6510	PD2000	CN2000	CN20	CN30		H01	G10	ST30A
ONMX 060608-MM				•					•								
ONHX 060608-MM				•					•								
ONMX 060608-MF				•					•								
ONHX 060608-MF				•					•								
ONHX 060608-W				•					•								
ONMX 0606ANN-MM				•	•	•			•								
ONHX 0606ANN-MM				•	•	•			•								
ONMX 0606ANN-MF					•	•			•								
ONHX 0606ANN-MF					•	•			•								
ONMX 060608-MA													•				

E11
E12

Применяемые оправки

Обозначение	Применяемые оправки	
	RM16AC	RM16ACM
RM16AC(M) 6063HR-M	-	BT□□-FMC22-□□
6080HR-M	BT□□-FMA25.4-□□	BT□□-FMC27-□□
6100HR-M	BT□□-FMA31.75-□□	BT□□-FMC32-□□
6125HR-M	BT□□-FMA38.1-□□	BT□□-FMB40-□□
6160R-M	BT□□-FMA50.8-□□	BT□□-FMC40-□□
6200R-M		
6250R-M		
6315R-M	BT□□-FMA47.625-□□	BT□□-FMB60-□□
6400R-M		

Комплектующие

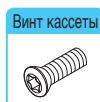

Винт кассеты



Ключ

FTGA0513

TW20-100



Применяемые СМП E11, E12



Присоединительные размеры смотреть на стр. E270-E272

• : Наличие на складе



RM16AC(M)8000

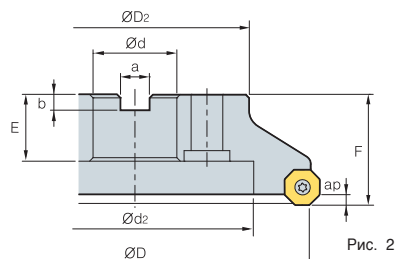
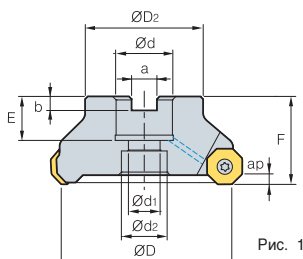

• AR : -6°
• RR : -6°

(MM)

Обозначение		ØD	ØD2	Ød	Ød1	Ød2	a	b	E	F	ap		Рис.	
RM16AC(M) 8063HR-M		5	63	49	22	11	18	10.4	6.3	20	40	5.5	0.7	1
8080HR-M		6	80	57	25.4(27)	14	20	9.5(12.4)	6(7)	25(23)	50	5.5	1.2	1
8100HR-M		7	100	67	31.75(32)	18	26	12.7(14.4)	8	33(25)	63(50)	5.5	1.8	1
8125HR-M		8	125	87	38.1(40)	22	32	15.9(16.4)	10(9)	35(29)	63	5.5	3.5	1
8160R-M		10	160	107	50.8(40)	-	107	19(16.4)	11(9)	38(32)	63	5.5	4.5	2
8200R-M		12	200	130	47.625(60)	-	135	25.4(25.7)	14(14)	38(32)	63	5.5	5.8	2
8250R-M		14	250	180	47.625(60)	-	180	25.4(25.7)	14	38	63	5.5	11.4	2
8315R-M		18	215	240	47.625(60)	-	238	25.4(25.7)	14	38	63	5.5	18.8	2
8400R-M		24	400	260	47.625(60)	-	238	25.4(25.7)	14	38	80	5.5	32.7	2

• () Метрическая система

Применяемые СМП

Обозначение	ONHX-MF	ONHX-MM	ONHX-W	ONHX-MA	ONMX-MF	ONMX-MM	Стр.											
	Тв. сплав с покрытием			Кермет		Тв. сплав												
	NCM325	NCM335	NC5330	PC3500	PC5300	PC5400	PC3545	PC9530	PC6510	PD2000	CN2000	CN20	CN30	H01	G10	ST30A	ST20	
ONMX 080608-MM				•	•													
ONHX 080608-MM																		
ONMX 080608-MF																		
ONHX 080608-MF																		
ONHX 080608-W				•														
ONMX 0806ANN-MM				•	•													
ONHX 0806ANN-MM						•												
ONMX 0806ANN-MF				•	•													
ONHX 0806ANN-MF					•	•												
ONHX 080608-MA														•				

Применяемые оправки

Обозначение	Применяемые оправки	
	RM16AC	RM16ACM
RM16AC(M) 8063HR-M	-	BT□□-FMC22-□□
8080HR-M	BT□□-FMA25.4-□□	BT□□-FMC27-□□
8100HR-M	BT□□-FMA31.75-□□	BT□□-FMC32-□□
8125HR-M	BT□□-FMA38.1-□□	BT□□-FMB40-□□
8160R-M	BT□□-FMA50.8-□□	BT□□-FMC40-□□
8200R-M		
8250R-M		
8315R-M	BT□□-FMA47.625-□□	BT□□-FMB60-□□
8400R-M		

Комплектующие



FTGA0513



TW20-100

RMT8A(M) 4000

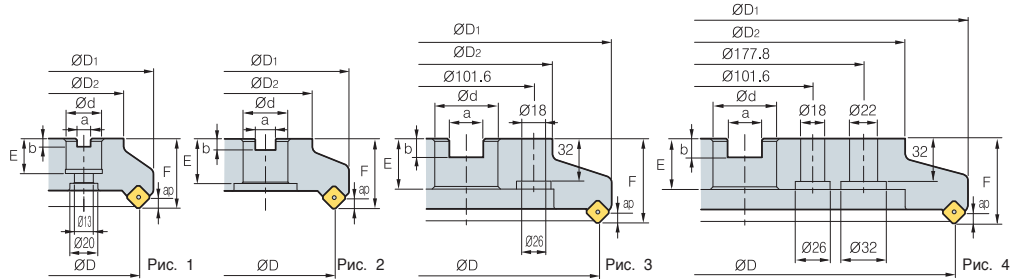

AA
45°
• AR : -6°
• RR : -6°

(MM)

Обозначение		ØD	ØD1	ØD2	Ød	a	b	E	F	ap		Рис.
RMT8A(M) 4080R	5	80	100	57	25.4(27)	9.5(12.4)	6(7)	25(22)	50	4	1.6	1
4080R-M	6	80	100	57	25.4(27)	9.5(12.4)	6(7)	25(22)	50	4	1.6	1
4100R	6	100	120	70	31.75(32)	12.7(14.4)	8(8)	32(28)	50	4	2.3	2
4100R-M	8	100	120	70	31.75(32)	12.7(14.4)	8(8)	32(28)	50	4	2.3	2
4125R	8	125	144	87	38.1(40)	15.9(16.4)	10(9)	38(30)	63	4	4.3	2
4125R-M	10	125	144	87	38.1(40)	15.9(16.4)	10(9)	38(30)	63	4	4.3	2
4160R	10	160	179	110	50.8(40)	19.0(16.4)	11(9)	38(30)	63	4	6.5	2
4160R-M	14	160	179	110	50.8(40)	19.0(16.4)	11(9)	38(30)	63	4	6.5	2
4200R	12	200	219	130	47.625(60)	25.4(25.7)	14(14)	38(38)	63	4	8.8	3
4200R-M	18	200	219	130	47.625(60)	25.4(25.7)	14(14)	38(38)	63	4	8.8	3
4250R	16	250	269	180	47.625(60)	25.4(25.7)	14(14)	38(38)	63	4	14.1	3
4250R-M	22	250	269	180	47.625(60)	25.4(25.7)	14(14)	38(38)	63	4	14.1	3
4315R	20	315	334	240	47.625(60)	25.4(25.7)	14(14)	38(38)	63	4	22.3	4
4315R-M	28	315	334	240	47.625(60)	25.4(25.7)	14(14)	38(38)	63	4	22.3	4

• () Метрическая система

Применяемые СМП

SNC(M)F-MF

SNC(M)F-MM



Обозначение	Тв. сплав с покрытием								Кермет			Тв. сплав			Стр.		
	NCM325	NCM335	NC5330	PC3500	PC5300	PC3545	PC9530	PC6510	PC215K	PD2000	CN2000	CN20	CN30	H01		G10	ST30A
SNCF 1206ANN-MF																	
1206ANN-MM				•													
SNMF 1206ANN-MF																	
1206ANN-MM																	

E17

Применяемые оправки

Обозначение	Оправка с хвостовиком NT	Оправка с хвостовиком BT	
		RMT8A	RMT8AM
RMT8A(M) <input type="checkbox"/> 080R	NT* <input type="checkbox"/> <input type="checkbox"/> (M/U)-FMA25.4-25	BT** <input type="checkbox"/> <input type="checkbox"/> -FMA25.4 - <input type="checkbox"/> <input type="checkbox"/>	FMC27
<input type="checkbox"/> 100R	NT* <input type="checkbox"/> <input type="checkbox"/> (M/U)-FMA31.75 - <input type="checkbox"/> <input type="checkbox"/>	BT** <input type="checkbox"/> <input type="checkbox"/> -FMA31.75 - <input type="checkbox"/> <input type="checkbox"/>	FMC32
<input type="checkbox"/> 125R	NT* <input type="checkbox"/> <input type="checkbox"/> (M/U)-FMA38.1 - <input type="checkbox"/> <input type="checkbox"/>	BT** <input type="checkbox"/> <input type="checkbox"/> -FMA38.1 - <input type="checkbox"/> <input type="checkbox"/>	FMB40
<input type="checkbox"/> 160R	NT* <input type="checkbox"/> <input type="checkbox"/> (M/U)-FMA50.8 - <input type="checkbox"/> <input type="checkbox"/>	BT** <input type="checkbox"/> <input type="checkbox"/> -FMA50.8 - <input type="checkbox"/> <input type="checkbox"/>	FMB60
<input type="checkbox"/> 200R	NT* <input type="checkbox"/> <input type="checkbox"/> (M/U)-FMA47.625-25, KCP-8***	BT** <input type="checkbox"/> <input type="checkbox"/> -FMA47.625- <input type="checkbox"/> <input type="checkbox"/>	
<input type="checkbox"/> 250R			
<input type="checkbox"/> 315R	KCP-8*** (Center Ring Plug)		

*-NT(No) **-BT(No) ***Для больших диаметров

Комплектующие



ETKA0523 KHB0417 SPR0315 LTC05SR-RM4 TW20-100



RMT8A(M)5000

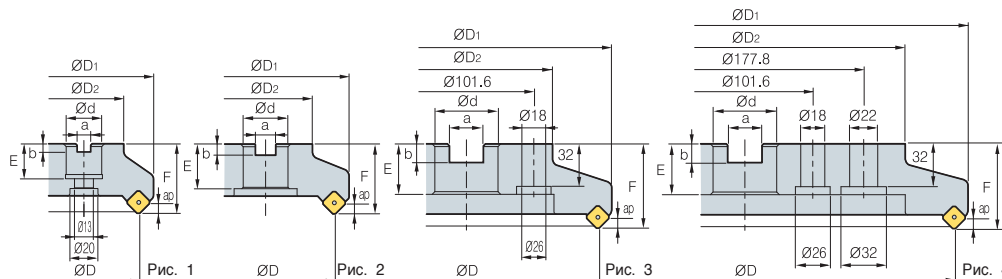

Обозначение			øD	øD ₁	øD ₂	ød	a	b	E	F	ap		Рис.
RMT8A(M)	5080R	5	80	104	57	25.4(27)	9.5(12.4)	6(7)	25(22)	50	6	1.8	1
	5080R-M	6	80	104	57	25.4(27)	9.5(12.4)	6(7)	25(22)	50	6	1.8	1
	5100R	6	100	124	70	31.75(32)	12.7(14.4)	8(8)	32(28)	50	6	2.6	2
	5100R-M	8	100	124	70	31.75(32)	12.7(14.4)	8(8)	32(28)	50	6	2.6	2
	5125R	8	125	149	87	38.1(40)	15.9(16.4)	10(9)	38(30)	63	6	4.3	2
	5125R-M	10	125	149	87	38.1(40)	15.9(16.4)	10(9)	38(30)	63	6	4.3	2
	5160R	10	160	184	110	50.8(40)	19.0(16.4)	11(9)	38(30)	63	6	6.5	2
	5160R-M	14	160	184	110	50.8(40)	19.0(16.4)	11(9)	38(30)	63	6	6.5	2
	5200R	12	200	224	130	47.625(60)	25.4(25.7)	14(14)	38(38)	63	6	9.0	3
	5200R-M	18	200	224	130	47.625(60)	25.4(25.7)	14(14)	38(38)	63	6	9.0	3
	5250R	16	250	274	180	47.625(60)	25.4(25.7)	14(14)	38(38)	63	6	14.4	3
	5250R-M	22	250	274	180	47.625(60)	25.4(25.7)	14(14)	38(38)	63	6	14.4	3
	5315R	20	315	339	240	47.625(60)	25.4(25.7)	14(14)	38(38)	63	6	22.2	4
	5315R-M	28	315	339	240	47.625(60)	25.4(25.7)	14(14)	38(38)	63	6	22.2	4

• () Метрическая система

Применяемые СМП

SNC(M)F-MF

SNC(M)F-MM



Обозначение	Тв. сплав с покрытием								Кермет			Тв. сплав			Стр.			
	NCM325	NCM335	NC5330	PC3500	PC5300	PC3545	PC9530	PC6510	PC215K	PD2000	CN2000	CN20	CN30	H01		G10	ST30A	ST20
SNCF 1507ANN-MF																		E17
1507ANN-MM				•		•												
SNMF 1507ANN-MF																		E17
1507ANN-MM				•														

Применяемые оправки

Обозначение	Оправка с хвостовиком NT	Оправка с хвостовиком BT	
		RMT8A	RMT8AM
RMT8A(M) <input type="checkbox"/> 080R	NT* <input type="checkbox"/> (M/U)-FMA25.4-25	BT** <input type="checkbox"/> -FMA25.4 - <input type="checkbox"/>	FMC27
<input type="checkbox"/> 100R	NT* <input type="checkbox"/> (M/U)-FMA31.75 - <input type="checkbox"/>	BT** <input type="checkbox"/> -FMA31.75 - <input type="checkbox"/>	FMC32
<input type="checkbox"/> 125R	NT* <input type="checkbox"/> (M/U)-FMA38.1 - <input type="checkbox"/>	BT** <input type="checkbox"/> -FMA38.1 - <input type="checkbox"/>	FMB40
<input type="checkbox"/> 160R	NT* <input type="checkbox"/> (M/U)-FMA50.8 - <input type="checkbox"/>	BT** <input type="checkbox"/> -FMA50.8 - <input type="checkbox"/>	
<input type="checkbox"/> 200R	NT* <input type="checkbox"/> (M/U)-FMA47.625-25, KCP-8***	BT** <input type="checkbox"/> -FMA47.625 - <input type="checkbox"/>	FMB60
<input type="checkbox"/> 250R			
<input type="checkbox"/> 315R	KCP-8*** (Center Ring Plug)		

* -NT(No) ** -BT(No) ***Для больших диаметров

Комплектующие



ETKA0625 KHB0417 SPR0415 LTC06SR-RM5 TW20-100

RMT8E(M)4000

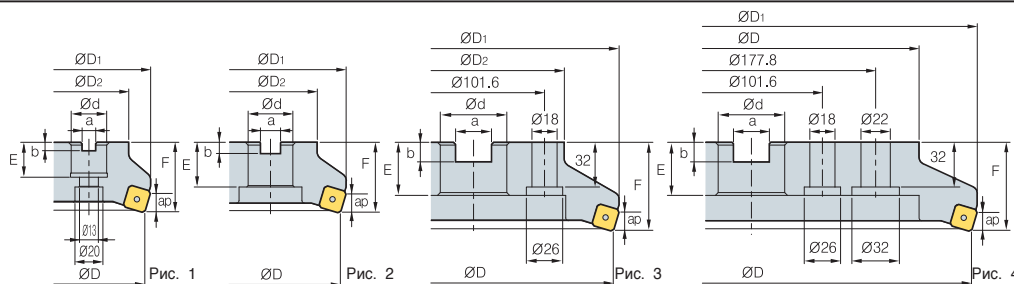

• AR : -6°
• RR : -8°~6°

(мм)

Обозначение		øD	øD ₁	øD ₂	ød	a	b	E	F	ap		Рис.	
RMT8E(M) 4080R		5	80	100	57	25.4(27)	9.5(12.4)	6(7)	25(22)	50	5	1.5	1
4080R-M		6	80	100	57	25.4(27)	9.5(12.4)	6(7)	25(22)	50	5	1.5	1
4100R		6	100	120	67	31.75(32)	12.7(14.4)	8(8)	32(28)	50	5	2	2
4100R-M		8	100	120	67	31.75(32)	12.7(14.4)	8(8)	32(28)	50	5	2	2
4125R		8	125	144	87	38.1(40)	15.9(16.4)	10(9)	38(30)	63	5	3.8	2
4125R-M		10	125	144	87	38.1(40)	15.9(16.4)	10(9)	38(30)	63	5	3.8	2
4160R		10	160	179	107	50.8(40)	19.0(16.4)	11(9)	38(30)	63	5	5.8	2
4160R-M		14	160	179	107	50.8(40)	19.0(16.4)	11(9)	38(30)	63	5	5.8	2
4200R		12	200	219	130	47.625(60)	25.4(25.7)	14(14)	38(38)	63	5	7.9	3
4200R-M		18	200	219	130	47.625(60)	25.4(25.7)	14(14)	38(38)	63	5	7.9	3
4250R		16	250	269	180	47.625(60)	25.4(25.7)	14(14)	38(38)	63	5	13.0	3
4250R-M		22	250	269	180	47.625(60)	25.4(25.7)	14(14)	38(38)	63	5	13.0	3
4315R		20	315	334	240	47.625(60)	25.4(25.7)	14(14)	38(38)	63	5	20.5	4
4315R-M		28	315	334	240	47.625(60)	25.4(25.7)	14(14)	38(38)	63	5	20.5	4

• () Метрическая система

Применяемые СМП

SNC(M)F-MF

SNC(M)F-MM



Обозначение	Тв. сплав с покрытием								Кермет			Тв. сплав				Стр.		
	NCM325	NCM335	NC5330	PC3500	PC5300	PC3545	PC9530	PC6510	PC215K	PD2000	CN2000	CN20	CN30	H01	G10		ST30A	ST20
SNCF 1206ENN-MF								•										E17
1206ENN-MM				•		•												
SNMF 1206ENN-MF				•														
1206ENN-MM				•														

Применяемые оправки

Обозначение	Оправка с хвостовиком NT	Оправка с хвостовиком BT	
		RMT8E	RMT8EM
RMT8E(M) <input type="checkbox"/> 080R	NT* <input type="checkbox"/> <input type="checkbox"/> (M/U)-FMA25.4-25	BT** <input type="checkbox"/> <input type="checkbox"/> -FMA25.4 - <input type="checkbox"/> <input type="checkbox"/>	FMC27
<input type="checkbox"/> 100R	NT* <input type="checkbox"/> <input type="checkbox"/> (M/U)-FMA31.75 - <input type="checkbox"/> <input type="checkbox"/>	BT** <input type="checkbox"/> <input type="checkbox"/> -FMA31.75 - <input type="checkbox"/> <input type="checkbox"/>	FMC32
<input type="checkbox"/> 125R	NT* <input type="checkbox"/> <input type="checkbox"/> (M/U)-FMA38.1 - <input type="checkbox"/> <input type="checkbox"/>	BT** <input type="checkbox"/> <input type="checkbox"/> -FMA38.1 - <input type="checkbox"/> <input type="checkbox"/>	FMB40
<input type="checkbox"/> 160R	NT* <input type="checkbox"/> <input type="checkbox"/> (M/U)-FMA50.8 - <input type="checkbox"/> <input type="checkbox"/>	BT** <input type="checkbox"/> <input type="checkbox"/> -FMA50.8 - <input type="checkbox"/> <input type="checkbox"/>	
<input type="checkbox"/> 200R	NT* <input type="checkbox"/> <input type="checkbox"/> (M/U)-FMA47.625-25, KCP-8***	BT** <input type="checkbox"/> <input type="checkbox"/> -FMA47.625 - <input type="checkbox"/> <input type="checkbox"/>	FMB60
<input type="checkbox"/> 250R			
<input type="checkbox"/> 315R	KCP-8*** (Center Ring Plug)		

* -NT(No) ** -BT(No) ***Для больших диаметров

Комплектующие

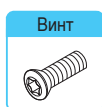

ETKA0523

KHB0417

SPR0315

LTC05SR-RM4

TW20-100



RMT8E(M)5000

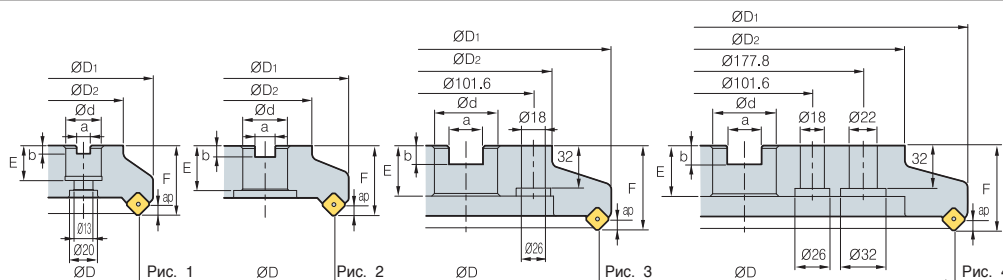

• AR : -6°
• RR : -8°~-6°

(MM)

Обозначение		øD	øD ₁	øD ₂	ød	a	b	E	F	ap		Рис.
RMT8E(M) 5080R	5	80	88	57	25.4(27)	9.5(12.4)	6(7)	25(22)	50	8	1.4	1
5080R-M	6	80	88	57	25.4(27)	9.5(12.4)	6(7)	25(22)	50	8	1.4	1
5100R	6	100	108	67	31.75(32)	12.7(14.4)	8(8)	32(28)	50	8	1.9	2
5100R-M	8	100	108	67	31.75(32)	12.7(14.4)	8(8)	32(28)	50	8	1.9	2
5125R	8	125	133	87	38.1(40)	15.9(16.4)	10(9)	38(30)	63	8	3.7	2
5125R-M	10	125	133	87	38.1(40)	15.9(16.4)	10(9)	38(30)	63	8	3.7	2
5160R	10	160	168	107	50.8(40)	19.0(16.4)	11(9)	38(30)	63	8	5.7	2
5160R-M	14	160	168	107	50.8(40)	19.0(16.4)	11(9)	38(30)	63	8	5.7	2
5200R	12	200	208	130	47.625(60)	25.4(25.7)	14(14)	38(38)	63	8	7.5	3
5200R-M	18	200	208	130	47.625(60)	25.4(25.7)	14(14)	38(38)	63	8	7.5	3
5250R	16	250	258	180	47.625(60)	25.4(25.7)	14(14)	38(38)	63	8	12.4	3
5250R-M	22	250	258	180	47.625(60)	25.4(25.7)	14(14)	38(38)	63	8	12.4	3
5315R	20	315	323	240	47.625(60)	25.4(25.7)	14(14)	38(38)	63	8	19.9	4
5315R-M	28	315	323	240	47.625(60)	25.4(25.7)	14(14)	38(38)	63	8	19.9	4

• () Метрическая система

Применяемые СМП

SNC(M)F-MF

SNC(M)F-MM



Обозначение	Тв. сплав с покрытием									Кермет			Тв. сплав				Стр.	
	NCM325	NCM335	NC5330	PC3500	PC5300	PC3545	PC9530	PC6510	PC215K	PD2000	CN2000	CN20	CN30	H01	G10	ST30A		ST20
SNCF 1507ENN-MF				•				•										E17
1507ENN-MM					•													
SNMF 1507ENN-MF																		
1507ENN-MM				•														

Применяемые оправки

Обозначение	Оправка с хвостиком NT	Оправка с хвостиком BT	
		RMT8E	RMT8EM
RMT8E(M) <input type="checkbox"/> 080R	NT* <input type="checkbox"/> <input type="checkbox"/> (M/U)-FMA25.4-25	BT** <input type="checkbox"/> <input type="checkbox"/> -FMA25.4 - <input type="checkbox"/> <input type="checkbox"/>	FMC27
<input type="checkbox"/> 100R	NT* <input type="checkbox"/> <input type="checkbox"/> (M/U)-FMA31.75 - <input type="checkbox"/> <input type="checkbox"/>	BT** <input type="checkbox"/> <input type="checkbox"/> -FMA31.75 - <input type="checkbox"/> <input type="checkbox"/>	FMC32
<input type="checkbox"/> 125R	NT* <input type="checkbox"/> <input type="checkbox"/> (M/U)-FMA38.1 - <input type="checkbox"/> <input type="checkbox"/>	BT** <input type="checkbox"/> <input type="checkbox"/> -FMA38.1 - <input type="checkbox"/> <input type="checkbox"/>	FMB40
<input type="checkbox"/> 160R	NT* <input type="checkbox"/> <input type="checkbox"/> (M/U)-FMA50.8 - <input type="checkbox"/> <input type="checkbox"/>	BT** <input type="checkbox"/> <input type="checkbox"/> -FMA50.8 - <input type="checkbox"/> <input type="checkbox"/>	FMB60
<input type="checkbox"/> 200R	NT* <input type="checkbox"/> <input type="checkbox"/> (M/U)-FMA47.625-25, KCP-8***	BT** <input type="checkbox"/> <input type="checkbox"/> -FMA47.625- <input type="checkbox"/> <input type="checkbox"/>	
<input type="checkbox"/> 250R			
<input type="checkbox"/> 315R			
	KCP-8*** (Center Ring Plug)		

* -NT(No) ** -BT(No) ***Для больших диаметров

Комплектующие



ЕТКА0625

КНВ0417

СПР0415

LTC06SR-RM5

TW20-100

RMT8Q(M)

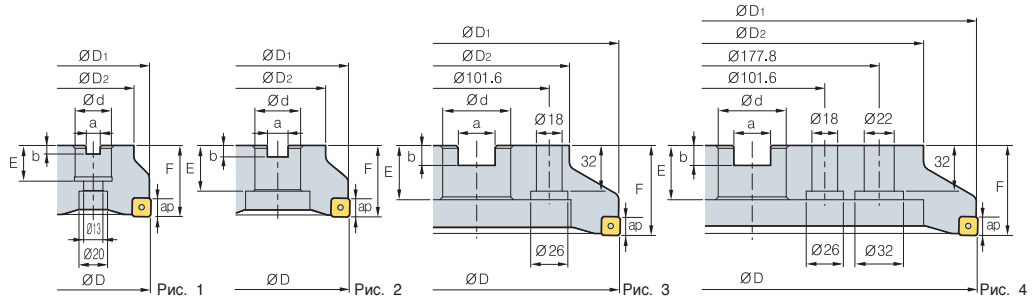
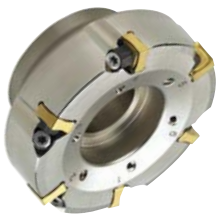

AA
88°

- AR : -6°
- RR : -11°~6°

													(мм)
Обозначение		ØD	ØD1	ØD2	Ød	a	b	E	F	ap		Рис.	
RMT8Q(M)	4080R	5	80	79	57	25.4(27)	9.5(12.4)	6(7)	25(22)	50	5	1.4	1
	4080R-M	6	80	79	57	25.4(27)	9.5(12.4)	6(7)	25(22)	50	5	1.4	1
	4100R	6	100	99	67	31.75(32)	12.7(14.4)	8(8)	32(28)	50	5	1.8	2
	4100R-M	8	100	99	67	31.75(32)	12.7(14.4)	8(8)	32(28)	50	5	1.8	2
	4125R	8	125	124	87	38.1(40)	15.9(16.4)	10(9)	38(30)	63	5	3.6	2
	4125R-M	10	125	124	87	38.1(40)	15.9(16.4)	10(9)	38(30)	63	5	3.6	2
	4160R	10	160	159	107	50.8(40)	19.0(16.4)	11(9)	38(30)	63	5	5.7	2
	4160R-M	14	160	159	107	50.8(40)	19.0(16.4)	11(9)	38(30)	63	5	5.7	2
	4200R	12	200	199	130	47.625(60)	25.4(25.7)	14(14)	38(38)	63	5	7.5	3
	4200R-M	18	200	199	130	47.625(60)	25.4(25.7)	14(14)	38(38)	63	5	7.5	3
	4250R	16	250	249	180	47.625(60)	25.4(25.7)	14(14)	38(38)	63	5	12.5	3
	4250R-M	22	250	249	180	47.625(60)	25.4(25.7)	14(14)	38(38)	63	5	12.5	3
	4315R	20	315	314	240	47.625(60)	25.4(25.7)	14(14)	38(38)	63	5	19.9	4
	4315R-M	28	315	314	240	47.625(60)	25.4(25.7)	14(14)	38(38)	63	5	19.9	4

() Метрическая система

Применяемые СМП

SNMF-MF



SNMF-MM



Обозначение	Тв. сплав с покрытием								Кермет			Тв. сплав				Стр.		
	NCM325	NCM335	NC5330	PC3500	PC5300	PC3545	PC9530	PC6510	PC215K	PD2000	CN2000	CN20	CN30	H01	G10		ST30A	ST20
SNMF 1206QNN-MF				•														E17
1206QNN-MM				•														

Применяемые оправки

Обозначение	Оправка с хвостовиком NT	Оправка с хвостовиком BT	
		RMT8Q	RMT8QM
RMT8Q(M) □080R	NT*□□(M/U)-FMA25.4-25	BT**□□-FMA25.4 -□□	FMC27
□100R	NT*□□(M/U)-FMA31.75-□□	BT**□□-FMA31.75 -□□	FMC32
□125R	NT*□□(M/U)-FMA38.1 -□□	BT**□□-FMA38.1 -□□	FMB40
□160R	NT*□□(M/U)-FMA50.8 -□□	BT**□□-FMA50.8 -□□	
□200R	NT*□□(M/U)-FMA47.625-25, KCP-8***	BT**□□-FMA47.625-□□	FMB60
□250R			
□315R	KCP-8*** (Center Ring Plug)		

*□□-NT(No) **□□-BT(No) ***Для больших диаметров

Комплектующие



ETKA0523 KHB0417 SPR0315 LTC05SR-RM4 TW20-100



Высокая точность и качество обработанной поверхности при чистовом фрезеровании.

Aero Mill

- Высокая эффективность обработки при высокоскоростном резании благодаря легкому алюминиевому корпусу, который составляет 50% веса традиционного стального корпуса фрезы.
 - Универсальность при обработке алюминия за счет применения СМП со шлифованной передней поверхностью и PKD.
 - Большой передний угол СМП обеспечивает снижение нагрузки и обеспечивает плавность работы.
- ПТочная балансировка до уровня G 2,5.

Схема сборки фрезы

- ▶ Значительный размер стружечной канавки предотвращает пакетирование стружки.
- ▶ Высокая жесткость корпуса.
- ▶ Наличие специального покрытия на поверхности стружечной канавки предотвращает налипание и уменьшает трение стружки.

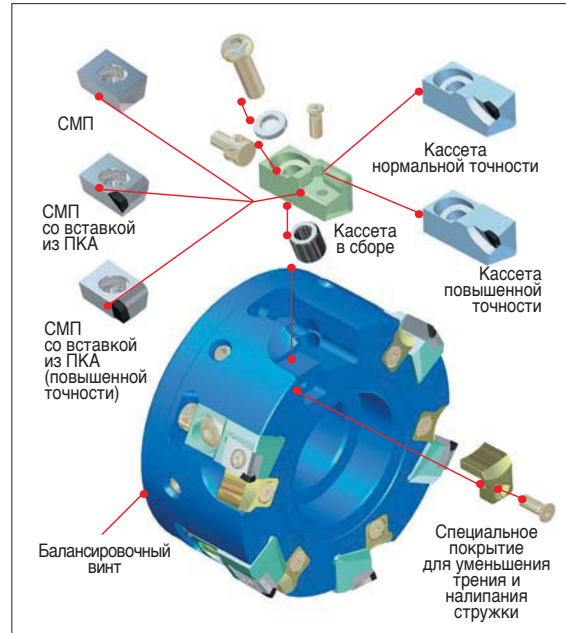

Система сквозного охлаждения

- ▶ Специально разработанная система сквозного охлаждения обеспечивает стабильную подачу СОЖ через центральное отверстие корпуса к СМП. Это улучшает эффективность охлаждения и удаления стружки из зоны резания.
- ▶ Распределитель охлаждения применим при диаметре фрезы до D160, запорная крышка – до D 200 и выше. Оба устройства для охлаждения приобретаются отдельно. При системе сквозного охлаждения подача СОЖ осуществляется через шпиндель.

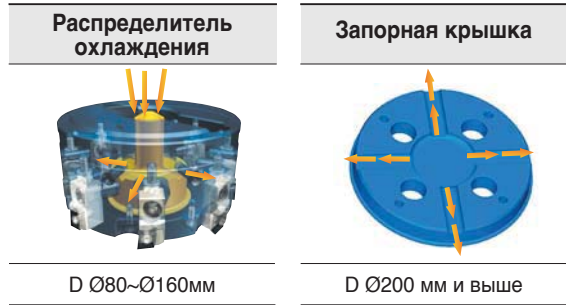

Область применения

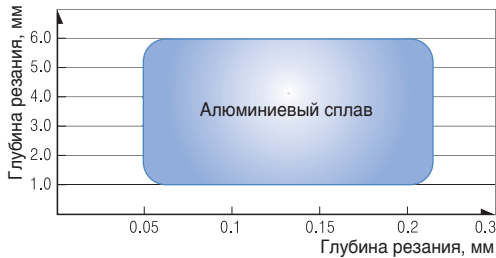

Рекомендуемые режимы резания

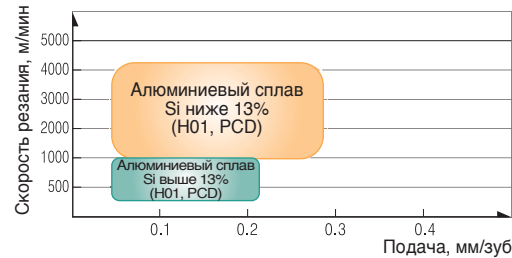

Шероховатость поверхности при максимально допустимой частоте вращения фрезы

- Режимы резания: V : 1570 м/мин S мин : 3000 мм/мин n : 5000 rpm S зуб : 0.1мм/зуб t : 0.5об/мин Модель станка : PCV62
- Обрабатываемые материалы : А6061
- Обозначение Фреза : APD100R-A6Z (6Flutes) СМП : CDEW1204R-XCF(H01)

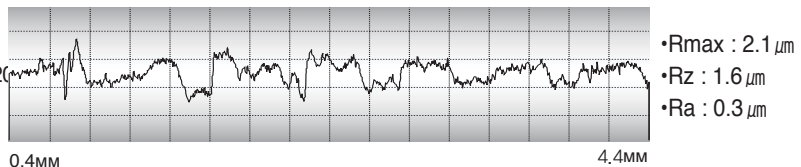

Максимально допустимая частота вращения, об/мин

Диаметр фрезы	Частота вращения, об/мин
Ø80	16,000
Ø100	15,000
Ø125	12,500
Ø160	10,000
Ø200	8,000
Ø250	6,500
Ø315	5,000

Выбор комплектующих для системы охлаждения

Диаметр	Тип	Обозначение	Общий вид	Примечание
Ø80	Coolant Bolt	CBP080-IN/MM		Типовая конструкция
Ø100	Coolant Bolt	CBP100-IN CBP100-MM-1		
Ø125	Coolant Bolt	CBP125-IN CBP125-MM-1		
Ø160	Coolant Bolt	CBP160-IN CBP160-MM		
Ø200	Coolant Cover	CCP200		
Ø250	Coolant Cover	CCP250		
Ø315	Coolant Cover	CCP315		

• Выбор: CBP100-IN: APD Тип генерал для безымянной пункта



Высокая эффективность применения для получистовой и чистовой обработки.

Aero Mill-Mini

- Высокая эффективность применения для получистовой и чистовой обработки.
- Высокая эксплуатационная надежность стального корпуса.
- Возможность применения СМП из марок сплава без покрытия и ПКА, согласно обрабатываемого материала.
- Балансированный корпус G2,5.



Система обозначение фрез

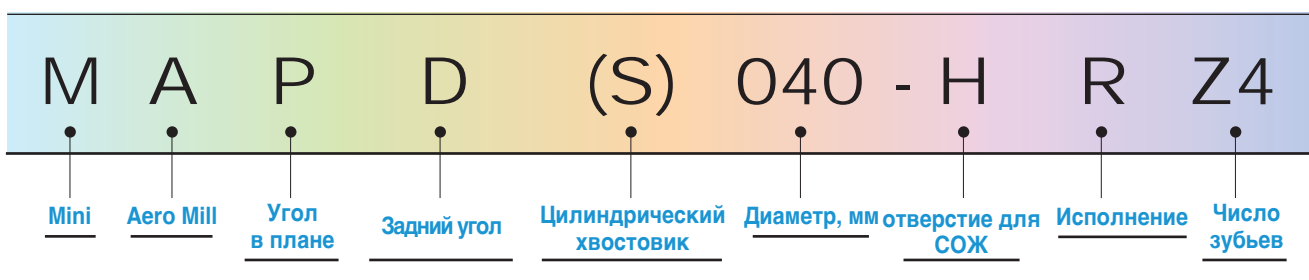

Особенности конструкции фрез

- ▶ Простота и надежность винтового крепления.
- ▶ Максимальный диапазон регулирования $\pm 0,1$ мм.
- ▶ Шаг регулировки: 2 мкм.
- ▶ Достаточный размер стружечной канавки для черновой обработки алюминия.
- ▶ Система внутреннего подвода СОЖ.

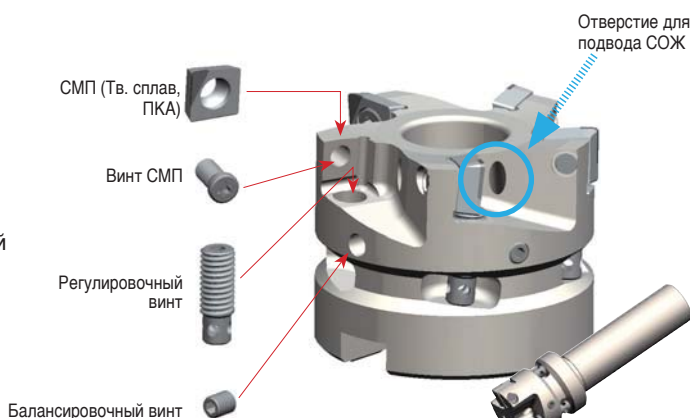

Область применения

Глубина PCD может быть длиной дифференцированного

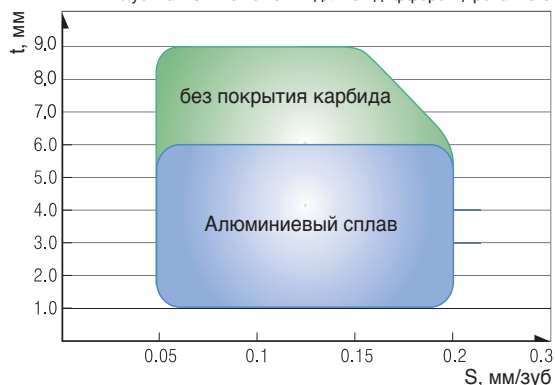

Область применения

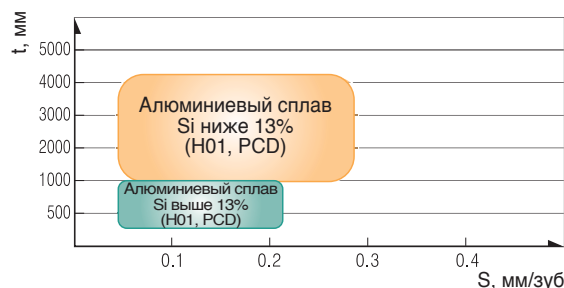

Максимальная частота вращения

Диаметр, мм	Частота, об/мин
Ø32	26,000
Ø40	24,500
Ø50	22,000
Ø63	20,000

APD(M)-A

Кассета + СМП

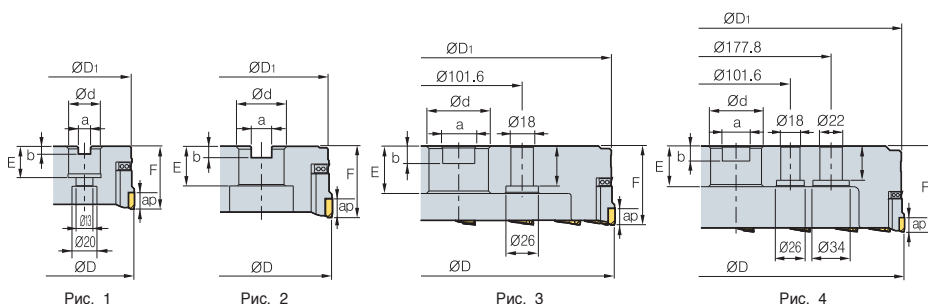
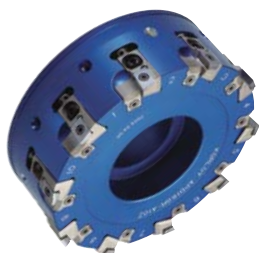

AA
90°
• AR : 6°
• RR : 5°~9°

Обозначение		ØD	ØD ₁	Ød	a	b	E	F	ap	Max rpm		Рис.
APD(M) 080R/L-A6Z	6	80	76	25.4(27)	9.5(12.4)	6(7)	25(22)	50	10	16000	0.75	1
100R/L-A6Z	6	100	95	31.75(32)	12.7(14.4)	8(8)	32(28)	50	10	15000	0.95	2
125R/L-A8Z	8	125	120	38.1(40)	15.9(16.4)	10(9)	38(30)	63	10	12500	1.8	2
160R/L-A10Z	10	160	155	50.8(40)	19.0(16.4)	11(9)	38(30)	63	10	10000	2.9	2
200R/L-A12Z	12	200	195	47.625(60)	25.4(25.7)	14(14)	38(38)	63	10	8000	4.0	3
250R/L-A16Z	16	250	245	47.625(60)	25.4(25.7)	14(14)	38(38)	63	10	6500	6.3	3
315R/L-A18Z	18	315	310	47.625(60)	25.4(25.7)	14(14)	38(38)	80	10	5000	11.3	4

() Метрическая система

Применяемые СМП

Обозначение	CDEW-XCF			CDEW-XAF,NAF				CDEW-XAW,NAW		Стр.
	Кермет	Кермет	Кермет	Тв. сплав		Тв. сплав		PCD		
	CN2000	CN20	CN30	H01	G10	ST30A	ST20	DP200		
CDEW 1204R-XCF				●	●				E06 E07	
1204L-XCF										
1204R-XAF								●		
1204L-XAF								●		
1204R-NAF								●		
1204R-XAW								●		
1204L-XAW								●		
1204R-NAW								●		

Применяемые оправки

Обозначение	Оправка с хвостовиком NT	Оправка с хвостовиком BT
APD(M) 080R/L	NT*□□(M/U)-FMA25.4-25	BT**□□-FMA25.4 - □□
100R/L	NT*□□(M/U)-FMA31.75 - □□	BT**□□-FMA31.75 - □□
125R/L	NT*□□(M/U)-FMA38.1 - □□	BT**□□-FMA38.1 - □□
160R/L	NT*□□(M/U)-FMA50.8 - □□	BT**□□-FMA50.8 - □□
200R/L	NT*□□(M/U)-FMA47.625-25, KCP-8***	BT**□□-FMA47.625 - □□
250R/L	NT*□□(M/U)-FMA47.625-25, KCP-8***	BT**□□-FMA47.625 - □□
315R/L	KCP-8*** (Без центрального отверстия)	-

*□□-NT(No) **□□-BT(No) ***Для больших диаметров

Рекомендации по выбору режимов резания и марки сплава

Обрабатываемые материалы	Режимы резания		Марка сплава
	V(м/мин)	Sz(мм/зуб)	
Алюминиевые сплавы	1,000 ~ 4,000	0.05 ~ 0.30	DP200 H01
	500 ~ 2,500	0.05 ~ 0.20	

Комплектующие

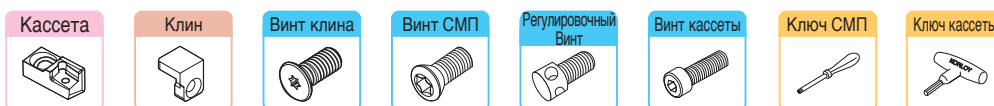

LAPDR/L-AJ CAPDR/L-AJ PTMA0411 FTNA0411 AZ0514 BHA0619-NYLOK TW15S HW50

APD(M)-B

КЛИН

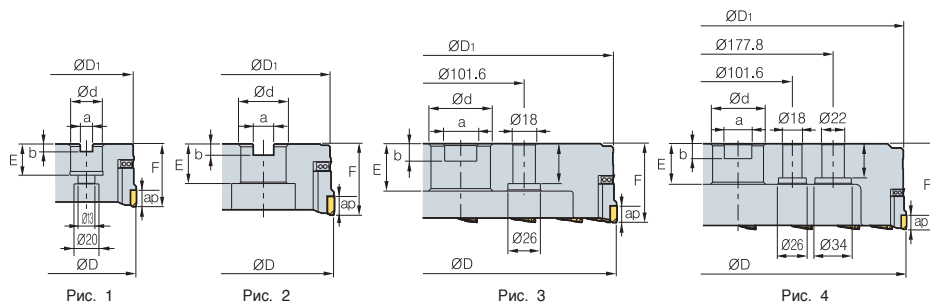
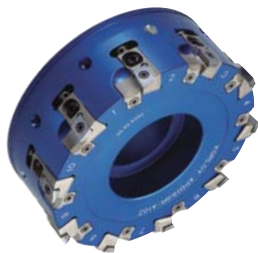

AA
90°
• AR : 6°
• RR : 5°~9°

(мм)

Обозначение		ØD	ØD ₁	Ød	a	b	E	F	ap	Max rpm		Рис.
APD(M) 080R/L-B6Z	6	80	76	25.4(27)	9.5(12.4)	6(7)	25(22)	50	6	16000	0.75	1
100R/L-B6Z	6	100	95	31.75(32)	12.7(14.4)	8(8)	32(28)	50	6	15000	0.95	2
125R/L-B8Z	8	125	120	38.1(40)	15.9(16.4)	10(9)	38(30)	63	6	12500	1.8	2
160R/L-B10Z	10	160	155	50.8(40)	19.0(16.4)	11(9)	38(30)	63	6	10000	2.9	2
200R/L-B12Z	12	200	195	47.625(60)	25.4(25.7)	14(14)	38(38)	63	6	8000	4.0	3
250R/L-B16Z	16	250	245	47.625(60)	25.4(25.7)	14(14)	38(38)	63	6	6500	6.3	3
315R/L-B18Z	18	315	310	47.625(60)	25.4(25.7)	14(14)	38(38)	80	6	5000	11.3	4

• AP-B (лезвия) Тип означает размер PCD.

• () Метрическая система

Применяемые СМП

ВAPDR-XAF

ВAPDR-XAW



Обозначение	PCD	Стр.
	DP200	
ВAPDR-XAF		E06
ВAPDL-XAF		
ВAPDR-XAW		
ВAPDL-XAW		

Применяемые оправки

Обозначение	Оправка с хвостовиком NT	Оправка с хвостовиком BT
APD(M) 080R/L	NT*□□ (M/U)-FMA25.4-25	BT**□□ -FMA25.4 -□□
100R/L	NT*□□ (M/U)-FMA31.75 -□□	BT**□□ -FMA31.75 -□□
125R/L	NT*□□ (M/U)-FMA38.1 -□□	BT**□□ -FMA38.1 -□□
160R/L	NT*□□ (M/U)-FMA50.8 -□□	BT**□□ -FMA50.8 -□□
200R/L	NT*□□ (M/U)-FMA47.625-25, KCP-8***	BT**□□ -FMA47.625 -□□
250R/L		
315R/L	KCP-8*** (Без центрального отверстия)	-

*□□-NT(No) **□□-BT(No) ***Для больших диаметров

Рекомендации по выбору режимов резания и марки сплава

Обрабатываемые материалы	Режимы резания		Марка сплава
	V(м/мин)	Sz(мм/зуб)	
Алюминиевые сплавы	1,000 ~ 4,000	0.05 ~ 0.30	DP200 H01
	500 ~ 2,500	0.05 ~ 0.20	

Комплектующие



Клин

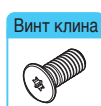

Винт клина



Винт СМП

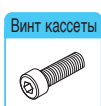

Винт кассеты



Ключ СМП

CAPDR/L-AJ PTMA0411 AZ0514 ВНА0619-NYLOK HW50

MAPDS000HR/L-Z0 *New*

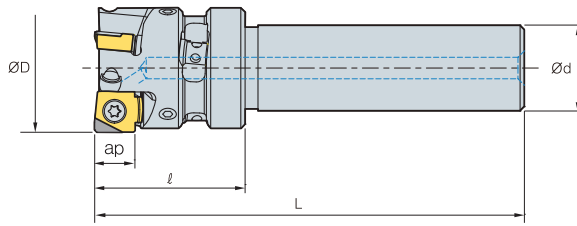

※ PCD a_p : 5 мм
※ без покрытия карбида a_p : 9мм



• AR : 6°
• RR : -4°~1°

(мм)

Обозначение		$\varnothing D$	$\varnothing d$	ℓ	L	a_p	Max частота вращения об/мин	
MAPDS 032HR/L-Z3	3	32	20	35	100	9.5	26,000	0.35
040HR/L-Z4	4	40	20	35	100	9.5	24,500	0.42

MAPD000HR/L-Z0 *New*

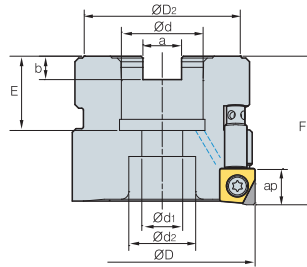

※ PCD a_p : 5 мм
※ без покрытия карбида a_p : 9мм



• AR : 6°
• RR : -1°~12°

(мм)

Обозначение		$\varnothing D$	$\varnothing D_2$	$\varnothing d$	a	b	E	F	$\varnothing d_1$	$\varnothing d_2$	a_p	Max rpm	
MAPD 040HR/L-Z4	4	40	34	16	8.4	5.6	18	40	9	14	9.5	24,000	0.24
050HR/L-Z5	5	50	42	22	10.4	6.3	20	40	11	18	9.5	22,000	0.35
063HR/L-Z6	6	63	42	22	10.4	6.3	20	40	11	18	9.5	20,000	0.65

Применяемые СМП

SNEW

SNEW-XAF

SNEW-NAF

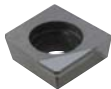
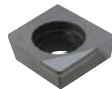
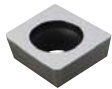

Обозначение	Кермет				Тв. сплав			PCD	Стр.
	CN2000	CN20	CN30	H01	G10	ST30A	ST20	DP200	
SNEW 09T3ADFR				●					E18
09T3ADTR-XAF								●	
09T3ADTR-NAF								●	

Применяемые оправки

Обозначение	Оправка с хвостовиком ВТ
MAPD 040HR/L-Z4	ВТ** <input type="checkbox"/> -FMC16- <input type="checkbox"/>
050HR/L-Z5	ВТ** <input type="checkbox"/> -FMC22- <input type="checkbox"/>
063HR/L-Z6	ВТ** <input type="checkbox"/> -FMC22- <input type="checkbox"/>

Рекомендации по выбору режимов резания и марки сплава

Обрабатываемые материалы	Режимы резания		Марка сплава
	V(м/мин)	Sz(мм/зуб)	
Алюминиевые сплавы	1,000 ~ 4,000	0.05 ~ 0.30	DP200 H01
	500 ~ 2,500	0.05 ~ 0.20	

Комплектующие



FTKA0408

AHX0617F-NYLOK

KHD0405

TW15S

HW20L

Распределитель охлаждения

Обозначение	Применяемые фрезы	
CB0525	MAPD040HR/L-Z4	$\varnothing 40$
CB1025	MAPD050HR/L-Z5	$\varnothing 50$
	MAPD063HR/L-Z6	$\varnothing 63$

Детальную информацию о распределителе охлаждения смотреть на стр. E96



Применяемые СМП E18



Присоединительные размеры смотреть на стр. E270~E272

● : Наличие на складе



Система обозначения фрез



PCD резак лица

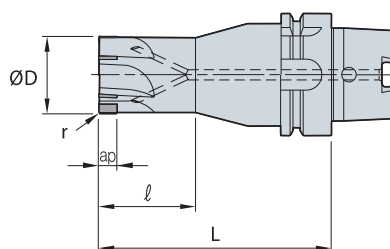
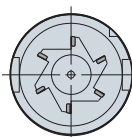

AA
90°
• AR : 6°
• RR : 5°~9°

Обозначение		$\varnothing D$	r	ap	l	L
PDF 4032-HSK50A	4	32	0.5	8	50	120
4040-HSK50A	4	40	0.5	8	50	120
4032-HSK63A	4	32	0.5	8	50	120
4040-HSK63A	4	40	0.5	8	50	120
4050-HSK63A	4	50	0.5	8	50	120
6063-HSK63A	6	63	0.5	12	-	100
6063-HSK100A	6	63	0.5	12	-	100

Рекомендации по выбору скорости резания

Обрабатываемые материалы	V (м/мин)	Sz (мм/зуб)	t , мм
Алюминий, бронза, цветные сплавы	200~2,000	0.02~0.1	0.05~4.0

Специальные PCD листа заказа



Рис. 1



Рис. 2

Обозначение	Рис.	Количество зубьев	Размеры, мм					Стандарт хвостовика
			$\varnothing D$	r	ap	l	L	
PDF								

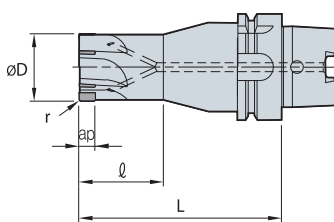
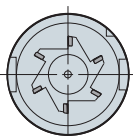
Универсальность в применении (фрезерования пазов, уступов, отверстий, ступенчатых плоскостей).

Alpha Mill

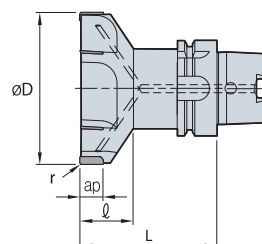
- Особая геометрия главной режущей кромки СМП позволяет с высокой точностью выдерживать угол в плане 90.
- Универсальность в применении (фрезерования пазов, уступов, отверстий, ступенчатых плоскостей).
- Высокая стойкость СМП при оптимальном выборе геометрии фрезы для соответствующих условий обработки.
- Высокая эффективность работы на больших глубинах резания благодаря малым силам резания и усиленной режущей кромке.

Характеристики СМП

• Высокая стойкость СМП при высокой скорости резания и подаче за счет оптимизации геометрии передней поверхности и усиленной режущей кромки.

• Оптимальное сопряжение поверхностей образующих передний угол способствуют снижению сил резания.

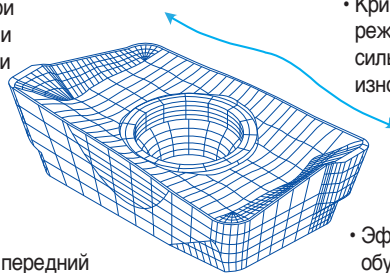

• Криволинейная геометрия главной режущей кромки позволяет уменьшить силы резания и повысить износостойкость.

• Эффективность применения СМП обуславливается оптимальным выбором марки твердого сплава для конкретно заданных условий обработки.

Рекомендации по предварительному выбору СМП





Обработка уступов				Обработка пазов	
Сверление		Тангенциальное врезание		Винтовое врезание	



Alpha Mill APMT-MA, ML

- Свойства**
- ▶ MA : Острая кромка и полированная поверхность улучшают смазывание при обработки алюминия .
 - ▶ ML : Режущая кромка и сплавы для труднообрабатываемых материалов (Ti, нержавеющие стали, Инконель) обеспечивают превосходную производительность при обработке

Характеристики и применение СМП





Тип	Стружколом	режущая кромка	Свойства
AI	MA		Оптимальная режущая кромка и полированная поверхность для обработки алюминия обеспечивают превосходную производительность при обработке
Труднообрабатываемый материал	ML		Стружколом с низкими силами резания является оптимальным для обработки труднообрабатываемых материалов..
Чистовая обработка	MF		Стружколом с более низкими усилиями резания и твердой режущей кромкой чем у ML, оптимально подходит для чистовой обработки
Общая обработка	MM		Оптимальна для фрезерования в общих диапазонах

конституция товаров

MA	ML
APMT0602PDFR-MA APMT0903PDFR-MA APMT11T3PDFR-MA APMT1604PDFR-MA APMT1806PDFR-MA	- APMT0903PDER-ML APMT11T3PDER-ML APMT1604PDER-ML APMT1806PDER-ML

- Пластины могут применяться для державок с типом APMT.

Рекомендации по предварительному выбору СМП

Стружколом	Геометрия режущей кромки	Рекомендации по выбору стружколома и марки сплава(● : 1st)											
		P		M		M		N		S			
		Низкоуглеродистые стали	Высокоуглеродистые и легированные стали	Нержавеющая сталь	Чугун	Алюминиевый сплав	Ti / Инконель						
		C/B	Марка сплава	C/B	Марка сплава	C/B	Марка сплава	C/B	Марка сплава	C/B	Марка сплава		
MA		-	-	-	-	-	-	●	● H01	-	-		
ML		-	-	●	● PC5300 ○ PC5400 ○ PC3545 ○ PC9530	-	-	-	-	●	● PC5300 ○ PC5400 ○ PC3545		
MF		●	● PC3500 ○ PC5300 ○ PC5400 ○ NCM325 ○ NCM335	-	○ PC3500 ○ PC3545 ○ NCM325 ○ NCM335	-	● PC5300 ○ PC5400 ○ PC3545 ○ PC9530	-	● PC6510 ○ PC5300 ○ PC5400	-	-	● PC5300 ○ PC5400 ○ PC3545	
MM		-	● PC3500 ○ PC5300 ○ PC5400 ○ NCM325 ○ NCM335	●	● PC3500 ○ PC5400 ○ NCM325 ○ NCM335	-	● PC5300 ○ PC5400 ○ PC3545 ○ PC9530	●	● PC6510 ○ PC5300 ○ PC5400	-	-	● PC5300 ○ PC5400 ○ PC3545	

Рекомендации по выбору глубины резания

1. Фрезерование пазов

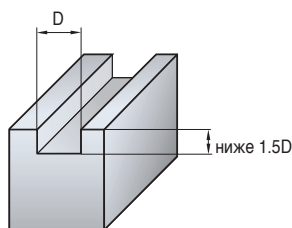

2. Фрезерование уступов

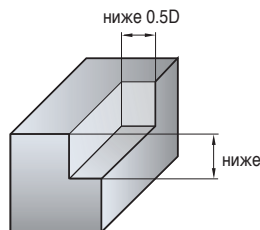

3. Фрезерование уступов

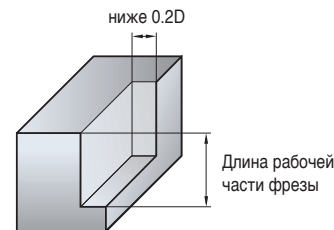

Рекомендации по выбору режимов резания (V,S для обработки пазов)

Обрабатываемые материалы	Марка сплава	Рис.	Диаметр фрезы, мм							
			Ø20, 25		Ø32, 40		Ø50, 63		Ø80, 100	
			V(м/мин)	Sz(мм/зуб)	V(м/мин)	Sz(мм/зуб)	V(м/мин)	Sz(мм/зуб)	V(м/мин)	Sz(мм/зуб)
Низкоуглеродистые стали	NCM325 PC3500	①	80~100	0.05~0.08	100~120	0.05~0.08	100~120	0.05~0.08	100~120	0.05~0.08
		②	100~120	0.08~0.10	120~140	0.08~0.10	120~140	0.08~0.10	120~140	0.08~0.10
		③	100~120	0.10~0.15	140~140	0.10~0.15	120~140	0.10~0.15	130~150	0.10~0.15
Высокоуглеродистые стали	NCM325 PC3500	①	60~80	0.05	80~100	0.05	80~100	0.05	80~100	0.05
		②	80~100	0.05~0.08	100~120	0.08~0.10	100~120	0.08~0.10	100~120	0.08~0.10
		③	80~100	0.10~0.15	110~130	0.10~0.15	100~120	0.10~0.15	110~130	0.10~0.15
Инструментальные стали	NCM325 PC3500	①	50~70	0.05	70~90	0.05	70~90	0.05	70~90	0.05
		②	60~80	0.05~0.08	90~120	0.05~0.08	100~120	0.05~0.08	100~120	0.05~0.08
		③	90~110	0.12~0.18	100~130	0.10~0.15	100~120	0.10~0.15	110~130	0.10~0.15
Нержавеющие стали	PC5300 PC9530	①	50~70	0.054	70~90	0.05	70~90	0.05	70~90	0.05
		②	60~80	0.05~0.08	90~120	0.05~0.08	100~120	0.05~0.08	100~120	0.05~0.08
		③	90~110	0.10~0.15	100~130	0.10~0.15	110~130	0.10~0.15	110~130	0.10~0.15
Чугуны	PC6510 PC5300	①	70~90	0.10~0.12	70~90	0.10~0.12	90~120	0.10~0.12	90~120	0.10~0.12
		②	80~100	0.12	90~120	0.12	100~140	0.12	100~140	0.12
		③	80~100	0.15~0.2	100~130	0.15~0.20	120~150	0.15~0.20	120~150	0.15~0.20
Алюминиевые сплавы	H01	①	200~800	0.10~0.2	300~900	0.10~0.20	400~1,000	0.10~0.20	400~1,000	0.10~0.20
		②	250~900	0.15~0.3	300~950	0.15~0.3	400~1,000	0.10~0.40	400~1,000	0.10~0.40
		③	250~900	0.15~0.3	300~950	0.15~0.3	400~1,000	0.10~0.40	400~1,000	0.10~0.40
Твердые сплавы	PC3545 PC5300	①	50~70	0.03	60~90	0.03	60~90	0.03	60~90	0.03
		②	60~80	0.05~0.08	80~100	0.05~0.08	80~100	0.05~0.08	80~100	0.05~0.08
		③	80~100	0.05~0.08	80~100	0.05~0.08	80~100	0.05~0.08	80~100	0.05~0.08

Рекомендации по выбору режимов резания (V,S для обработки уступов)

Обрабатываемые материалы	Марка сплава	Рис.	Диаметр фрезы, мм							
			Ø20, 25		Ø32, 40		Ø50, 63		Ø80, 100	
			V(м/мин)	Sz(мм/зуб)	V(м/мин)	Sz(мм/зуб)	V(м/мин)	Sz(мм/зуб)	V(м/мин)	Sz(мм/зуб)
Низкоуглеродистые стали	NCM325 PC3500	①	60~80	0.05~0.08	80~120	0.05~0.08	120~200	0.05~0.08	150~200	0.05~0.08
		②	80~120	0.08~0.10	120~180	0.08~0.10	180~250	0.08~0.10	200~250	0.08~0.10
		③	80~120	0.10~0.15	120~180	0.10~0.15	180~250	0.10~0.15	200~250	0.10~0.15
Высокоуглеродистые стали	NCM325 PC3500	①	50~80	0.05	80~110	0.05	100~150	0.05	100~150	0.05
		②	80~100	0.05~0.08	110~150	0.05~0.10	150~200	0.05~0.10	150~200	0.05~0.10
		③	80~100	0.10~0.15	120~150	0.10~0.15	180~200	0.10~0.15	80~200	0.10~0.15
Инструментальные стали	NCM325 PC3500	①	50~70	0.05	80~100	0.05	100~130	0.05	100~130	0.05
		②	70~100	0.05~0.08	100~130	0.05~0.10	130~180	0.05~0.10	130~180	0.05~0.10
		③	70~100	0.10~0.15	100~150	0.10~0.15	130~180	0.10~0.15	130~180	0.10~0.15
Нержавеющие стали	PC5300 PC9530	①	50~70	0.05	80~100	0.05	100~130	0.05	100~130	0.05
		②	70~100	0.05~0.08	100~130	0.05~0.10	130~180	0.05~0.10	130~180	0.05~0.10
		③	70~100	0.10~0.15	100~150	0.10~0.15	130~180	0.10~0.15	130~180	0.10~0.15
Чугуны	PC6510 PC5300	①	80~100	0.08~0.12	80~100	0.15	120~150	0.15	120~150	0.15
		②	100~120	0.12~0.15	100~130	0.15~0.18	150~200	0.15~0.18	150~200	0.15~0.18
		③	100~120	0.15~0.20	100~130	0.15~0.20	150~200	0.15~0.20	150~200	0.15~0.20
Алюминиевые сплавы	H01	①	250~800	0.15~0.20	300~900	0.15~0.20	400~1,000	0.10~0.20	400~1,000	0.10~0.20
		②	250~900	0.20~0.25	350~950	0.20~0.25	400~1,000	0.20~0.30	400~1,000	0.20~0.30
		③	250~900	0.25~0.3	350~950	0.25~0.30	400~1,000	0.30~0.10	400~1,000	0.30~0.40
Твердые сплавы	PC3545 PC5300	①	50~70	0.03	60~90	0.03	60~90	0.03	60~90	0.03
		②	60~80	0.05~0.08	80~100	0.05~0.08	80~100	0.05~0.08	80~100	0.05~0.08
		③	80~100	0.05~0.08	80~100	0.05~0.08	80~100	0.05~0.08	80~100	0.05~0.08



Выбор оптимальных режимов резания и способов врезания

1. Тангенциальное врезание

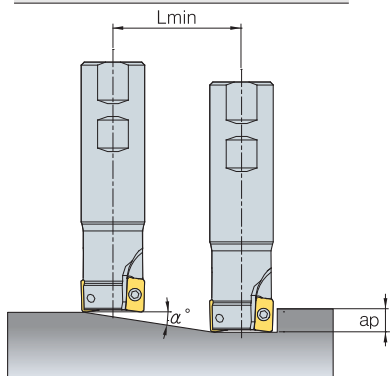

2. Винтовое врезание для глухих отверстий

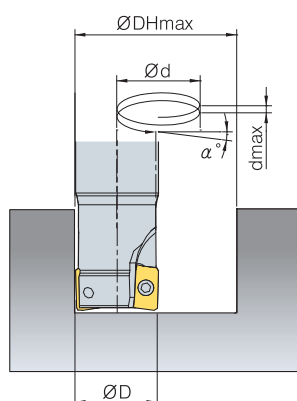

3. Винтовое врезание для сквозных отверстий

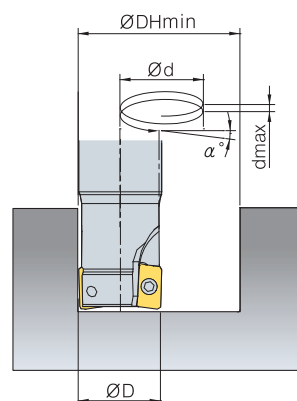

Обозначение	Диаметр фрезы, мм	Тангенциальное врезание		Винтовое врезание для глухих отверстий				Винтовое врезание для сквозных отверстий		
		t	Максимальный угол, α°	Длина врезания, мм	Максимальный диаметр внешнего отверстия (окружности), мм	Максимальный шаг винтовой линии, мм	Минимальный диаметр отверстия, мм	Максимальный шаг винтовой линии, мм	Минимальный диаметр отверстия, мм	Максимальный шаг винтовой линии, мм
AMS1010HS	10	5	6.5	44	18.8	2.1	17.6	2.0	13	1.5
AMS1011HS	11		5.6	51	20.8	2.0	19.6	1.9	15	1.5
AMS1012HS	12		4.9	58	22.8	2.0	21.6	1.9	17	1.5
AMS1014HS	14		3.9	73	26.8	1.8	25.6	1.8	21	1.4
AMS1015HS	15		3.6	80	28.8	1.8	27.6	1.7	23	1.4
AMS1016HS	16		3.3	87	30.8	1.8	29.6	1.7	25	1.4
AMS1017HS	17		3.0	94	32.8	1.7	31.6	1.7	27	1.4
AMS1018HS	18		2.8	101	34.8	1.7	33.6	1.7	29	1.4
AMS1020HS	20		2.5	115	38.8	1.7	37.6	1.6	33	1.4
AMS1021HS	21		2.3	123	40.8	1.7	39.6	1.6	35	1.4
AMS1022HS	22		2.2	130	42.8	1.6	41.6	1.6	37	1.4
AMS1025HS	25		1.9	151	48.8	1.6	47.6	1.6	43	1.4
AMS1026HS	26		1.8	158	50.8	1.6	49.6	1.6	45	1.4
AMS1032HS	32		1.4	201	62.8	1.6	61.6	1.5	57	1.4
AMS1033HS	33		1.4	208	64.8	1.6	63.6	1.5	59	1.4
AMC1032HS	32		1.4	201	62.8	1.6	61.6	1.5	57	1.4
AMC1040HS	40		1.1	258	78.8	1.5	77.6	1.5	73	1.4
AMC1050HS	50		0.9	330	98.8	1.5	97.6	1.5	93	1.4
AMC1063HS	63		0.7	423	124.8	1.5	123.6	1.5	119	1.4
AMS1510HS	10		9	7.5	68	18.8	2.5	17.4	2.3	11
AMS1512HS	12	6.5		79	22.8	2.6	21.4	2.4	15	1.7
AMS1513HS	13	5.7		90	24.8	2.5	23.4	2.3	17	1.7
AMS1514HS	14	6.3		82	26.8	2.9	25.4	2.8	19	2.1
AMS1516HS	16	5.0		102	30.8	2.7	29.4	2.6	23	2.0
AMS1517HS	17	4.6		112	32.8	2.6	31.4	2.5	25	2.0
AMS1518HS	18	4.2		122	34.8	2.6	33.4	2.5	27	2.0
AMS1519HS	19	3.9		132	36.8	2.5	35.4	2.4	29	2.0
AMS1520HS	20	3.6		142	38.8	2.5	37.4	2.4	31	2.0
AMS1521HS	21	3.4		152	40.8	2.4	39.4	2.3	33	2.0
AMS1522HS	22	3.2		162	42.8	2.4	41.4	2.3	35	1.9
AMS1524HS	24	2.8		182	46.8	2.3	45.4	2.2	39	1.9
AMS1525HS	25	2.7		192	48.8	2.3	47.4	2.2	41	1.9
AMS1528HS	28	2.3		222	54.8	2.2	53.4	2.2	47	1.9
AMS1530HS	30	2.1		242	58.8	2.2	57.4	2.1	51	1.9
AMS1532HS	32	2.0		262	62.8	2.2	61.4	2.1	55	1.9
AMS1535HS	35	1.8		292	68.8	2.1	67.4	2.1	61	1.9
AMS1540HS	40	1.5		342	78.8	2.1	77.4	2.0	71	1.9
AMC15040HS	40	1.5		342	78.8	2.1	77.4	2.0	71	1.9
AMC15050HS	50	1.2		442	98.8	2.0	97.4	2.0	91	1.9
AMC15063HS	63	0.9	572	124.8	2.0	123.4	1.9	117	1.8	
AMC15080HS	80	0.7	742	158.8	1.9	157.4	1.9	151	1.8	
AMC15100HS	100	0.5	942	198.8	1.9	197.4	1.9	191	1.8	

$$L_{\min} = \frac{ap}{\tan \alpha} \text{ (мм)}$$



Выбор оптимальных режимов резания и способов врезания

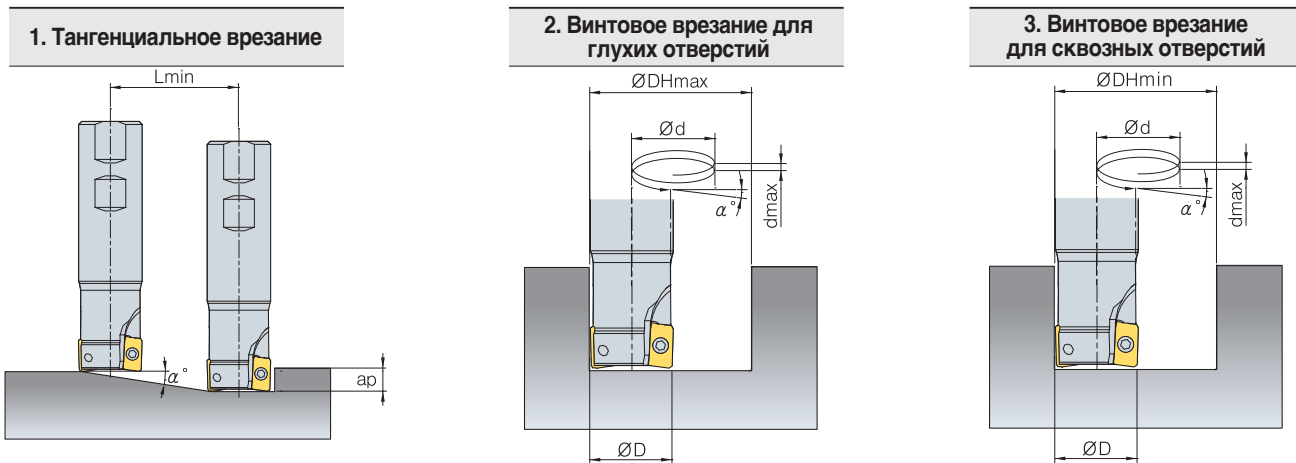

Обозначение	Диаметр фрезы, мм	Тангенциальное врезание		Винтовое врезание для глухих отверстий				Винтовое врезание для сквозных отверстий			
		t	Максимальный угол, α°	Длина врезания, мм	Максимальный диаметр внешнего отверстия (окружности), мм	Максимальный шаг винтовой линии, мм	Минимальный диаметр отверстия, мм	Максимальный шаг винтовой линии, мм	Минимальный диаметр отверстия, мм	Максимальный шаг винтовой линии, мм	
AMS2010HS	10	10	16.82	33	18	5.4	16.4	5.0	11	3.3	
AMS2012HS	12		11.69	48	22	4.6	20.4	4.2	15	3.1	
AMS2014HS	14		7.55	75	26	3.4	24.4	3.2	19	2.5	
AMS2016HS	16		10.30	55	30	5.5	28	5.1	23	4.2	
AMS2018HS	18		8.23	69	34	4.9	32	4.6	27	3.9	
AMS2020HS	20		5.60	102	38	3.7	36	3.5	31	3.0	
AMS2022HS	22		5.15	111	42	3.8	40	3.6	35	3.2	
AMS2025HS	25		3.92	146	48	3.3	46	3.2	41	2.8	
AMS2032HS	32		2.70	212	62	2.9	60	2.8	55	2.6	
AMS2040HS	40		1.98	289	78	2.7	76	2.6	71	2.5	
AMS2050HS	50		1.48	386	98	2.5	96	2.5	91	2.4	
AMS2063HS	63		1.11	514	124	2.4	122	2.4	117	2.3	
AMC2050HS	50		0.36	1576	98	0.6	96	0.6	91	0.6	
AMC2063HS	63		0.27	2104	124	0.6	122	0.6	117	0.6	
AMC2080HS	80		0.21	2784	158	0.6	156	0.6	151	0.5	
AMC2100HS	100		0.16	3584	198	0.6	196	0.5	191	0.5	
AMS3025HS	25	10	4.72	121	48	4.0	46	3.8	36	3.0	
AMS3032HS	32		3.00	191	62	3.2	60	3.1	50	2.6	
AMS3040HS	40		2.29	250	78	3.1	76	3.0	66	2.6	
AMS3050HS	50		1.64	350	98	2.8	96	2.7	86	2.5	
AMS3063HS	63		1.22	470	124	2.6	122	2.6	112	2.4	
AMC3040HS	40		1.99	288	78	2.7	76	2.6	66	2.3	
AMC3050HS	50		1.67	343	98	2.9	96	2.8	86	2.5	
AMC3063HS	63		1.22	470	124	2.6	122	2.6	112	2.4	
AMC3080HS	80		0.90	636	158	2.5	156	2.5	146	2.3	
AMC3100HS	100		0.69	830	198	2.4	196	2.4	186	2.2	
AMS2025MH	25		10	1.50	764	48	1.3	46	1.2	-	-
AMS2032MH	32			1.50	1146	62	1.6	60	1.6	-	-
AMS3040MH	40		16	1.50	1528	78	2.0	76	2.0	-	-
AMS4020HS	20		16	9.5	98	38.8	6.5	37.4	6.2	31	5.2
AMS4021HS	21			5.2	179	40.8	3.7	39.4	3.6	33	3.0
AMS4025HS	25			7.6	122	48.8	6.5	47.4	6.3	41	5.5
AMS4026HS	26	7.1		130	50.8	6.4	49.4	6.2	43	5.4	
AMS4032HS	32	3.4		276	62.8	3.7	61.4	3.6	55	3.3	
AMS4033HS	33	3.2		288	64.8	3.7	63.4	3.6	57	3.2	
AMS4040HS	40	2.5		376	78.8	3.4	77.4	3.4	71	3.1	
AMS4050HS	50	1.9		502	98.8	3.2	97.4	3.2	91	3.0	
AMS4063HS	63	1.4		665	124.8	3.1	123.4	3.0	117	2.9	
AMC4050HS	50	1.9		502	98.8	3.2	97.4	3.2	91	3.0	
AMC4063HS	63	1.4		665	124.8	3.1	123.4	3.0	117	2.9	
AMC4080HS	80	1.1		878	158.8	2.9	157.4	2.9	151	2.8	
AMC4100HS	100	0.8		1128	198.8	2.9	197.4	2.9	191	2.8	
AMC4125HS	125	0.6		1442	248.8	2.8	247.4	2.8	241	2.7	

$$L \min = \frac{ap}{\tan \alpha} \text{ (мм)}$$



AMC(M)1000S

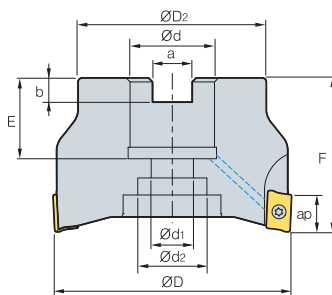

(MM)

Обозначение		$\varnothing D$	$\varnothing D_2$	$\varnothing d$	$\varnothing d_1$	$\varnothing d_2$	a	b	E	F	ap	
AMC(M) 1032HS	8	32	30	16	9	14	8.4	5.6	19	40	5.6	0.15
1040HS-16	10	40	34	16	9	14	8.4	5.6	19	40	5.6	0.24
1040HS-22	10	40	34	22	11	18	10.4	6.3	21	40	5.6	0.24
1050HS	12	50	42	22	11	18	10.4	6.3	21	40	5.6	0.36
1063HS	14	63	49	22	11	18	10.4	6.3	21	40	5.6	0.61

Применяемые СМП

APMT-MM

APMT-MF



Обозначение	Тв. сплав с покрытием									Кермет			Тв. сплав				Стр.	
	NCM325	NCM335	NC5330	PC3500	PC5300	PC5400	PC3545	PC9530	PC6510	PD2000	CN2000	CN20	CN30	H01	G10	ST30A		ST20
APMT 0602PDFR-MA																		
060202PDSR-MM			●	●	●	●	●											
0602PDSR-MM			●	●	●	●	●	●	●									
060208PDSR-MM			●	●	●	●	●											
060212R-MM			●	●	●	●	●											

Применяемые оправки

Обозначение	$\varnothing d$	Оправка с хвостовиком BT
AMC(M) 1032HS	16	BT □□-FMC16-□□
1040HS-16		
1040HS-22		
1050HS	22	BT □□-FMC22-□□
1063HS		

Комплектующие

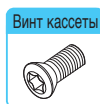

Винт кассеты



Ключ

FTKA01842

TW06S-A

AMC(M)1500S

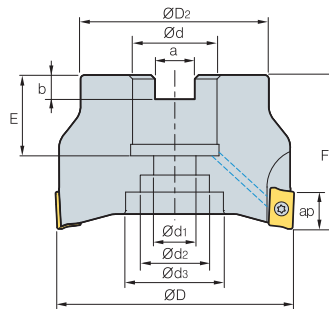
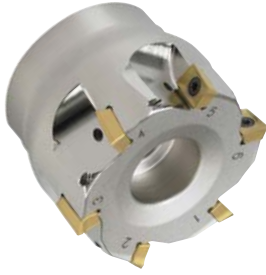

• AR : 9°~13°
• RR : -14°~5°

(MM)

Обозначение		ØD	ØD ₂	Ød	Ød ₁	Ød ₂	Ød ₃	a	b	E	F	ap	kg
AMC(M) 1504OHS	5	40	34	16	9	14	-	8.4	5.6	19	40	9	0.22
1505OHS	6	50	42	22	11	18	-	10.4	6.3	21	40	9	0.34
15063HS	8	63	49	22	11	18	-	10.4	6.3	21	40	9	0.57
1508OHS	10	80	57	25.4(27)	14	25	35	9.5(12.4)	6(7)	24(23)	50	9	1.10
1510OHS	12	100	67	31.75(32)	18	26	42	12.7(14.4)	8(8)	32(26)	63	9	2.10

• () Метрическая система

Применяемые СМП

APMT-MA

APMT-ML

APMT-MM



Обозначение	Тв. сплав с покрытием									Кермет			Тв. сплав				Стр.
	NCM325	NCM335	NC5330	PC3500	PC5300	PC5400	PC3545	PC9530	PC6510	PD2000	CN2000	CN20	CN30	H01	G10	ST30A	
APMT 0903PDFR-MA																	
0903PDER-ML																	
0903PDSR-MM			•	•	•	•	•										
090308PDSR-MM			•	•	•	•	•										
090312R-MM						•	•										
090316R-MM					•	•											
090320R-MM					•	•											

Применяемые оправки

Обозначение	Ød	Оправка с хвостовиком BT
AMC(M) 1504OHS	16	BT□□-FMC16-□□
1505OHS	22	BT□□-FMC22-□□
15063HS		
1508OHS	25.4	BT□□-FMA25.4-□□
	27	BT□□-FMC27-□□
1510OHS	31.75	BT□□-FMA31.75-□□
	32	BT□□-FMC32-□□

Комплектующие

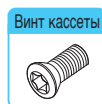

FTKA02565S

TW08S



AMC(M)2000S

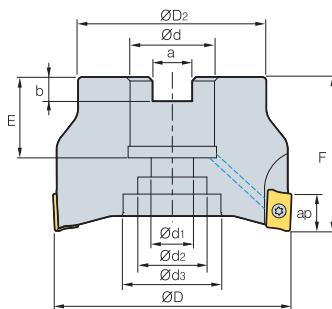

Обозначение		⊙	ØD	ØD ₂	Ød	Ød ₁	Ød ₂	Ød ₃	a	b	E	F	ap	kg
AMC(M)	2040HS	5	40	34	16	9	14	-	8.4	5.6	18	40	11	0.22
	2050HS	6	50	42	22	11	18	-	10.4	6.3	20	40	11	0.34
	2063HS	8	63	49	22	11	18	-	10.4	6.3	20	40	11	0.57
	2080HS	8	80	57	25.4(27)	14	25	35	9.5(12.4)	6(7)	25(22)	50	11	1.10
	2100HS	10	100	67	31.75(32)	18	26	42	12.7(14.4)	8(8)	32(28)	63	11	2.10

() Метрическая система

Применяемые СМП

		APMT-MA		APMT-ML		APMT-MM		APMT-MF											
		Тв. сплав с покрытием								Кермет		Тв. сплав							
Обозначение		NCM825	NCM835	NC5330	PC3500	PC5300	PC5400	PC3545	PC9530	PC6510	PD2000	CN2000	CN20	CN30	H01	G10	ST30A	ST20	Стр.
APMT	11T3PDFR-MA																		E05
	11T3PDER-ML																		
	11T3PDSR-MM	●		●	●	●	●	●	●	●									
	11T3PDSR-MF	●		●	●	●	●	●	●	●									
	11T308PDSR-MM	●		●	●	●	●	●	●	●									
	11T312PDSR-MM	●		●	●	●	●	●	●	●									
	11T316R-MM	●		●	●	●	●	●	●	●									
	11T318R-MM																		
	11T324R-MM			●	●	●		●											

Применяемые оправки

Обозначение		Ød	Оправка с хвостовиком BT
AMC(M)	2040HS	16	BT □□-FMC16-□□
	2050HS	22	BT □□-FMC22-□□
	2063HS	25.4	BT □□-FMA25.4-□□
		27	BT □□-FMC27-□□
	2100HS	31.75	BT □□-FMA31.75-□□
32		BT □□-FMC32-□□	

Комплектующие

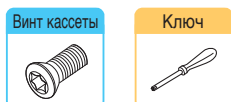

FTKA02565S TW08S

AMC(M) 3000S

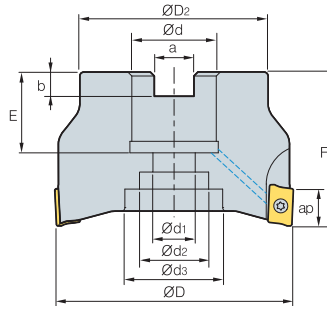
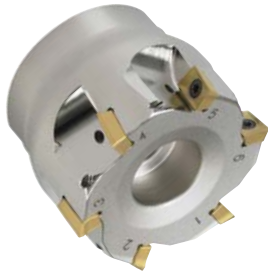

AA
90°
• AR : 14°
• RR : -12°~8°

(mm)

Обозначение		$\varnothing D$	$\varnothing D_2$	$\varnothing d$	$\varnothing d_1$	$\varnothing d_2$	$\varnothing d_3$	a	b	E	F	ap	
AMC(M) 3040HS	4	40	34	16	9	14	-	8.4	5.6	18	40	16	0.18
3050HS	5	50	42	22	11	18	-	10.4	6.3	20	40	16	0.28
3063HS	6	63	49	22	11	18	-	10.4	6.3	20	40	16	0.50
3080HS	7	80	57	25.4(27)	14	25	35	9.5(12.4)	6(7)	25(22)	50	16	1.02
3100HS	8	100	67	31.75(32)	18	26	42	12.7(14.4)	8(8)	32(28)	63	16	2.05

• () Метрическая система

Применяемые СМП

Обозначение	APMT-MA		APMT-ML				APMT-MM			APMT-MF				Стр.				
	NCM325	NCM335	NC5330	PC3500	PC5300	PC5400	PC3545	PC9530	PC6510	PD2000	CN2000	CN20	CN30		H01	G10	ST30A	ST20
APMT 1604PDFR-MA																		E05
1604PDER-ML						•												
1604PDSR-MM	•		•	•	•	•	•	•	•									
1604PDSR-MF	•		•	•	•	•	•	•	•									
160410PDSR-MM	•		•	•	•	•	•	•	•									
160416PDSR-MM	•		•	•	•	•	•	•	•									
160424R-MM			•	•	•	•	•	•	•									
160430R-MM						•	•	•	•									
160432R-MM	•		•	•	•	•	•	•	•									

Применяемые оправки

Обозначение	$\varnothing d$	Оправка с хвостовиком BT
AMC(M) 3040HS	16	BT □□-FMC16-□□
3050HS	22	BT □□-FMC22-□□
3063HS		
3080HS	25.4	BT □□-FMA25.4-□□
	27	BT □□-FMC27-□□
	31.75	BT □□-FMA31.75-□□
3100HS	32	BT □□-FMC32-□□

Комплектующие

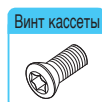

FTKA0410

TW15S



AMC(M)4000S

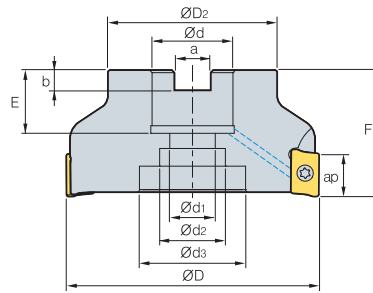

AA
90°

• AR : 13°~15°
• RR : -12°~7°

(mm)

Обозначение	ØD	ØD ₂	Ød	Ød ₁	Ød ₂	Ød ₃	a	b	E	F	ap	kg
AMC(M) 4050HS	50	42	22	11	18	-	10.4	6.3	21	40	17	0.28
4063HS	63	49	22	11	18	-	10.4	6.3	21	40	17	0.50
4080HS	80	57	25.4(27)	14	25	35	9.5(12.4)	6(7)	24(23)	50	17	1.00
4100HS	100	67	31.75(32)	18	26	42	12.7(14.4)	8(8)	32(25)	63(50)	17	2.10
4125HS	125	87	38.1(40)	22	32	52	15.9(16.4)	10(9)	35(29)	63	17	3.30
4160S	160	107	50.8(40)	-	-	100	19(16.4)	11(9)	38(32)	63	17	3.6
4200S	200	108	47.625(60)	-	-	132	25.4(25.7)	14(14)	40(38)	63	17	6

• () Метрическая система

Применяемые СМП

APMT-MA

APMT-ML

APMT-MM

APMT-MF



Обозначение	Тв. сплав с покрытием								Кермет			Тв. сплав				Стр.		
	NCM325	NCM335	NC5330	PC3500	PC5300	PC5400	PC3545	PC9530	PC6510	PD2000	CN2000	CN20	CN30	H01	G10		ST30A	ST20
APMT 1806PDR-MA																		
1806PDR-ML						•												
1806PDR-MM	•		•	•	•	•	•	•	•									
1806PDR-MF			•		•	•	•											
180612PDR-MM	•		•	•	•	•	•											
180616PDR-MM			•		•	•												
180620PDR-MM			•		•	•												
180624PDR-MM			•	•		•												
180630R-MM			•		•	•												
180632R-MM			•	•		•	•											

Применяемые оправки

Обозначение	Ød	Оправка с хвостовиком ВТ	Обозначение	Ød	Оправка с хвостовиком ВТ
AMC(M) 4050HS	22	BT□□-FMC22-□□	AMC(M) 4125HS	38.1	BT□□-FMA38.1-□□
4063HS	25.4	BT□□-FMA25.4-□□		40	BT□□-FMC40-□□
4080HS	27	BT□□-FMC27-□□	4160S	50.8	BT□□-FMA50.8-□□
	31.75	BT□□-FMA31.75-□□		40	BT□□-FMC40-□□
4100HS	32	BT□□-FMC32-□□	4200S	47.625	BT□□-FMA47.625-□□
				60	BT□□-FMB60-□□

Комплектующие

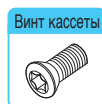

FTKA0410



TW15S



AMC(M) 1000SE/2000SE

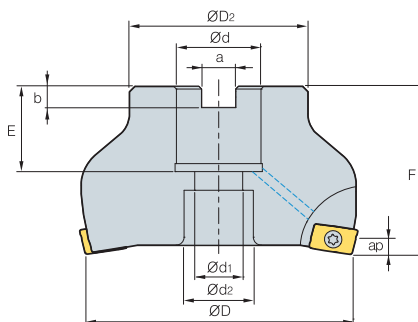

• AR : 45°
• RR : 0°

Обозначение		ØD	ØD2	Ød	Ød1	Ød2	a	b	E	F	ap	(MM)	
AMC(M)	1040HSE	4	40	34	16	9	14	8.4	5.6	19	40	2.5	0.26
	1050HSE	5	50	42	22	11	18	10.4	6.3	21	40	2.5	0.39
AMC(M)	2080HSE	5	80	57	25.4(27)	14	20	9.5(12.4)	6.0(7.0)	25(22)	50	4	1.2
	2100HSE	6	100	67	31.75(32)	18	26	12.7(14.4)	8.0(8.0)	32(28)	63	4	2.33

• () Метрическая система

Применяемые СМП

APMT-MM



APMT-MF



Тип	Обозначение	Тв. сплав с покрытием								Кермет			Тв. сплав				Стр.	
		NCM325	NCM335	NC5330	PC3500	PC5300	PC5400	PC5545	PC9530	PC6510	PD2000	CN2000	CN20	CN80	H01	G10		ST30A
1000 Тип	APMT 060202PDSR-MM			•	•	•	•	•	•									
	0602PDSR-MM			•	•	•	•	•	•									
	060208PDSR-MM			•	•	•	•	•	•									
	060212R-MM			•	•	•	•	•	•									
2000 Тип	APMT 11T3PDSR-MM	•		•	•	•	•	•	•	•								
	11T3PDSR-MF	•		•	•	•	•	•	•	•								
	11T308PDSR-MM	•		•	•	•	•	•	•	•								
	11T312PDSR-MM	•		•	•	•	•	•	•	•								
	11T316R-MM	•		•	•	•	•	•	•	•								
	11T318R-MM	•		•	•	•	•	•	•	•								
	11T324R-MM	•		•	•	•	•	•	•	•								

Применяемые оправки

Тип	Обозначение	Ød	Оправка с хвостовиком BT
1000 Тип	AMC(M) 1040HSE	16	BT□□-FMC16-□□
	1050HSE	22	BT□□-FMC22-□□
2000 Тип	AMC(M) 2080HSE	25.4	BT□□-FMA25.4-□□
		27	BT□□-FMC27-□□
	2100HSE	31.75	BT□□-FMA31.75-□□
		32	BT□□-FMC32-□□

Комплектующие

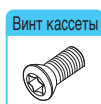

1000 Тип	FTKA01842	-	TW06S-A
2000 Тип	FTKA02565S	TW08S	-

AMC(M)3000SE

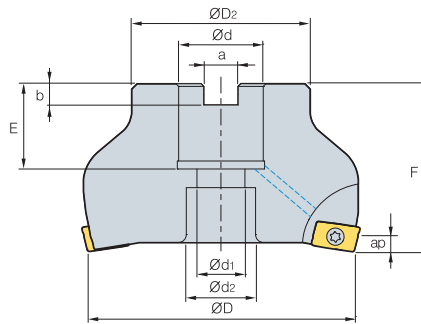
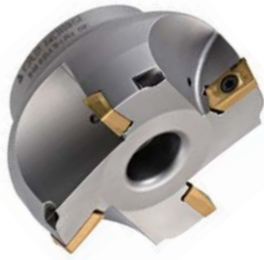

• AR : 45°
• RR : 0°

(MM)

Обозначение		ØD	ØD ₂	Ød	Ød ₁	Ød ₂	a	b	E	F	ap	
AMC(M) 3080HSE	4	80	57	25.4(27)	14	20	9.5(12.4)	6.0(7.0)	25(22)	50	6	1.3
3100HSE	5	100	67	31.75(32)	18	26	12.7(14.4)	8.0(8.0)	32(28)	63	6	2.3

• () Метрическая система

Применяемые СМП

APMT-MM

APMT-MF



Обозначение	Тв. сплав с покрытием								Кермет			Тв. сплав				Стр.	
	NCM325	NCM335	NC5330	PC3500	PC5300	PC5400	PC3545	PC9530	PC6510	PD2000	CN2000	CN20	CN30	H01	G10		ST30A
APMT 1604PDSR-MM	●		●	●	●	●	●	●									
1604PDSR-MF	●		●	●	●	●	●	●									
160410PDSR-MM	●				●	●	●	●									
160416PDSR-MM	●		●	●	●	●	●	●									
160424R-MM			●	●	●	●	●	●									
160430R-MM					●	●	●	●									
160432R-MM	●		●	●	●	●	●	●									

Применяемые оправки

Обозначение	Ød	Оправка с хвостовиком BT
AMC(M) 3080HSE	25.4	BT□□-FMA25.4-□□
	27	BT□□-FMC27-□□
3100HSE	31.75	BT□□-FMA31.75-□□
	32	BT□□-FMC32-□□

Комплектующие

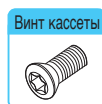

Винт кассеты



Ключ

FTKA0410

TW08S



AMC(M)2000M

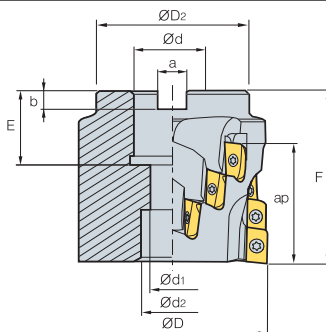

AA
90°
• AR : 9°
• RR : -9°~5°

(мм)

Обозначение		$\varnothing D$	$\varnothing D_2$	$\varnothing d$	$\varnothing d_1$	$\varnothing d_2$	a	b	E	F	Количество зубьев	ap		
AMC(M) 2050M		16	50	40	22.225(22)	11	18	8(10.4)	5(6.3)	29(21)	58	4	39	0.7
2063M		16	63	50	25.4(27)	13.5	20	9.5(12.4)	6(7)	25(25)	58	4	39	0.8
2080M		20	80	60	31.75(32)	-	45	12.7(14.4)	8(8)	35(28)	63	5	39	0.96
2100M		24	100	80	38.1(40)	-	56	15.9(16.4)	10(9)	38(30)	63	6	39	1.2

• () Метрическая система

Применяемые СМП

	APMT-MA	APMT-ML	APMT-MM	APMT-MF														
Обозначение	Тв. сплав с покрытием								Кермет			Тв. сплав		Стр.				
	NCM825	NCM835	NC5330	PC3500	PC5300	PC5400	PC3545	PC9530	PC6510	PD2000	CN2000	CN20	CN30		H01	G10	ST30A	ST20
APMT 11T3PDR-MA																		E05
11T3PDR-ML																		
11T3PDR-MM	•		•	•	•	•	•	•	•									
11T3PDR-MF	•		•	•	•	•	•	•	•									
11T308PDR-MM	•		•	•	•	•	•	•	•									
11T312PDR-MM	•		•	•	•	•	•	•	•									
11T316R-MM	•		•	•	•	•	•	•	•									
11T318R-MM	•		•	•	•	•	•	•	•									
11T324R-MM			•	•	•													

Применяемые оправки

Обозначение	$\varnothing d$	Оправка с хвостовиком BT	
AMC(M) 2050M	22.225	BT □□ -FMA22.225-□□	BT □□ -SMA22.225-□□
	22	BT □□ -FMC22-□□	BT □□ -SMC22-□□
2063M	25.4	BT □□ -FMA25.4-□□	BT □□ -SMA25.4-□□
	27	BT □□ -FMC27-□□	BT □□ -SMC27-□□
2080M	31.75	BT □□ -FMA31.75-□□	BT □□ -SMA31.75-□□
	32	BT □□ -FMC32-□□	BT □□ -SMC32-□□
2100M	38.1	BT □□ -FMA38.1-□□	BT □□ -SMA38.1-□□
	40	BT □□ -FMC40-□□	BT □□ -SMC40-□□

Рекомендации по выбору СМП

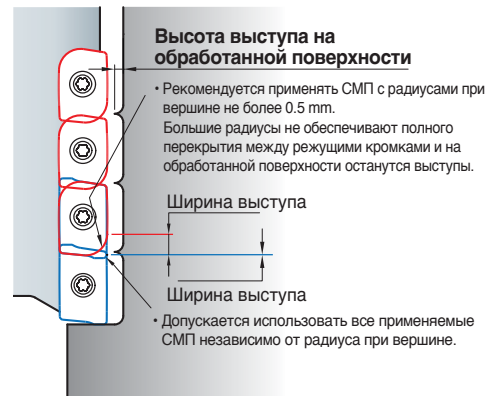

Комплектующие

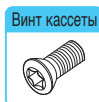

Винт кассеты



Ключ

FTKA02565S

TW08S

AMC(M) 3000M

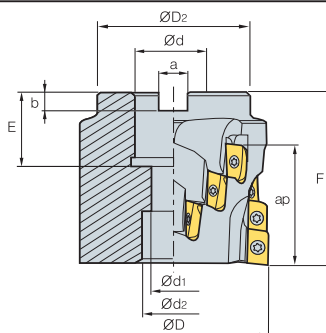

Обозначение			ØD	ØD2	Ød	Ød1	Ød2	a	b	E	F	Количество зубьев	ap	
AMC(M)	3063M	16	63	57	25.4(27)	14	20	9.5(12.4)	6(7)	38(38)	85	4	57	1.1
	3080M	20	80	67	31.75(32)	14	26	12.7(14.4)	8(8)	40(40)	100	4	71	2.23
	3100M	30	100	87	38.1(40)	22	32	15.9(16.4)	10(9)	40(40)	100	6	71	3.59

() Метрическая система

Применяемые СМП

	APMT-MA	APMT-ML	APMT-MM	APMT-MF	Тв. сплав с покрытием								Кермет			Тв. сплав			Стр.				
Обозначение					NCM325	NCM335	NC5330	PC3500	PC5300	PC5400	PC3545	PC9530	PC6510	PD2000	CN2000	CN20	CN30	H01	G10	ST30A	ST20		
APMT 1604PDR-MA																							
1604PDR-ML																							
1604PDR-MM					•		•	•	•	•	•	•	•										
1604PDR-MF					•		•	•	•	•	•	•	•										
160410PDR-MM					•		•	•	•	•	•	•	•										
160416PDR-MM					•		•	•	•	•	•	•	•										
160424R-MM							•	•	•	•	•	•	•										
160430R-MM																							
160432R-MM					•		•	•	•	•	•	•	•										

Применяемые оправки

Обозначение	Ød	Оправка с хвостовиком BT	
AMC(M) 3063M	25.4	BT□□-FMA25.4-□□	BT□□-SMA25.4-□□
	27	BT□□-FMC27-□□	BT□□-SMC27-□□
3080M	31.75	BT□□-FMA31.75-□□	BT□□-SMA31.75-□□
	32	BT□□-FMC32-□□	BT□□-SMC32-□□
3100M	38.1	BT□□-FMA38.1-□□	BT□□-SMA38.1-□□
	40	BT□□-FMC40-□□	BT□□-SMC40-□□

Рекомендации по выбору СМП

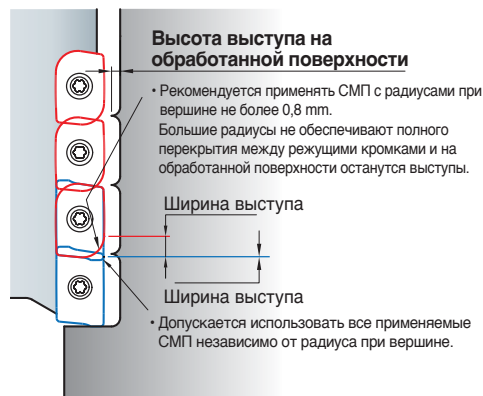

Комплектующие

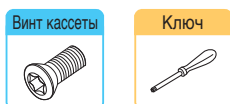

ФТКА0410 TW15S

AMC(M)4000M

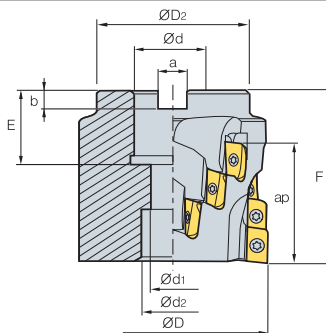

AA
90°
• AR : 9°
• RR : -9°~5°

Обозначение			$\varnothing D$	$\varnothing D_2$	$\varnothing d$	$\varnothing d_1$	$\varnothing d_2$	$\varnothing d_3$	a	b	E	F	Количество зубьев	ap	
AMC(M)	4063M	16	63	57	25.4(27)	14	20	28	9.5(12.4)	6(7)	38(38)	85	4	61.1	1.1
	4080M	20	80	67	31.75(32)	14	26	40	12.7(14.4)	8(8)	40(40)	100	4	76.1	2.23
	4100M	30	100	87	38.1(40)	22	32	60	15.9(16.4)	10(9)	40(40)	100	6	76.1	3.59
	4125M	18	125	87	38.1(40)	22	32	52	15.9(16.4)	10(9)	36(29)	68	6	46.1	4.0

(MM)

• () Метрическая система

Применяемые СМП

Обозначение	Тв. сплав с покрытием								Кермет			Тв. сплав				Стр.		
	NCM325	NCM335	NC5330	PC3500	PC3300	PC5400	PC3545	PC9530	PC6510	PD2000	CN2000	CN20	CN30	H01	G10		ST30A	ST20
APMT 1806PDFR-MA																		
1806PDER-ML																		
1806PDSR-MM	•		•	•	•	•	•	•	•									
1806PDSR-MF			•	•	•	•	•	•	•									
180612PDSR-MM	•		•	•	•	•	•	•	•									
180616PDSR-MM			•	•	•	•	•	•	•									
180620PDSR-MM			•	•	•	•	•	•	•									
180624PDSR-MM			•	•	•	•	•	•	•									
180630R-MM			•	•	•	•	•	•	•									
180632R-MM			•	•	•	•	•	•	•									

Применяемые оправки

Обозначение	$\varnothing d$	Оправка с хвостовиком BT			
AMC(M) 4063M	25.4	BT□□-FMA25.4-□□	BT□□-SMA25.4-□□		
	27	BT□□-FMC27-□□	BT□□-SMC27-□□		
4080M	31.75	BT□□-FMA31.75-□□	BT□□-SMA31.75-□□		
	32	BT□□-FMC32-□□	BT□□-SMC32-□□		
4100M	38.1	BT□□-FMA38.1-□□	BT□□-SMA38.1-□□		
	40	BT□□-FMC40-□□	BT□□-SMC40-□□		
4125M	38.1	BT□□-FMA38.1-□□	BT□□-SMA38.1-□□		
	40	BT□□-FMC40-□□	BT□□-SMC40-□□		

Рекомендации по выбору СМП

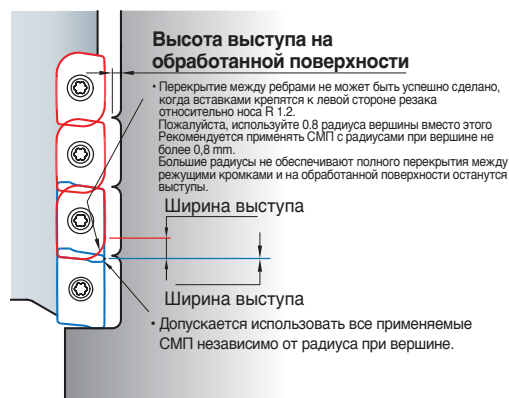

Комплектующие

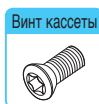

Винт кассеты



Ключ

FTKA0410

TW15S



AMS1000S

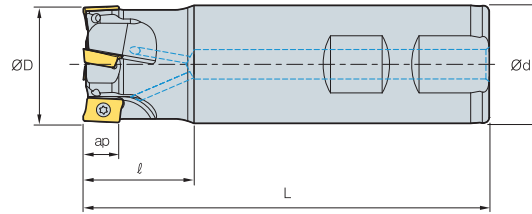

AA
90°
• AR : 7.5°~13°
• RR : -17°~6°

(MM)

Обозначение		ØD	ød	ℓ	L	ap		
AMS	1010HS	2	10	10	20	80	5.6	0.04
	1011HS	2	11	10	20	80	5.6	0.04
	1012HS-2	2	12	12	25	80	5.6	0.06
	1012HS-2L12	2	12	12	25	120	5.6	0.09
	1012HS-3	3	12	12	25	80	5.6	0.06
	1014HS-2	2	14	16	25	90	5.6	0.11
	1014HS-2L16	2	14	16	25	140	5.6	0.18
	1014HS-3	3	14	16	25	90	5.6	0.11
	1015HS	3	15	16	25	90	5.6	0.11
	1015HS-3L16	3	15	16	25	140	5.6	0.18
	1016HS-3	3	16	16	25	90	5.6	0.12
	1016HS-3L16	3	16	16	25	160	5.6	0.22
	1016HS-4	4	16	16	25	90	5.6	0.12
	1017HS	4	17	16	25	90	5.6	0.12
	1017HS-3L16	3	17	16	25	160	5.6	0.22
	1018HS	4	18	16	25	90	5.6	0.12
	1018HS-4L16	4	18	16	25	180	5.6	0.25
	1020HS-4	4	20	20	30	110	5.6	0.23
	1020HS-4L20	4	20	20	30	200	5.6	0.43
	1020HS-5	5	20	20	30	110	5.6	0.23
	1021HS	5	21	20	30	110	5.6	0.24
	1021HS-4L20	4	21	20	30	200	5.6	0.43
	1022HS	5	22	20	30	110	5.6	0.27
	1025HS	7	25	25	30	120	5.6	0.39
	1026HS	7	26	25	30	120	5.6	0.39
	1032HS	8	32	32	35	120	5.6	0.65
	1033HS	8	33	32	35	120	5.6	0.65

Применяемые СМП

* () Метрическая система

APMT-MA

APMT-MM



Обозначение	Тв. сплав с покрытием									Кермет			Тв. сплав				Стр.	
	NCM325	NCM335	NC5330	PC3500	PC5300	PC5400	PC3545	PC9530	PC6510	PD2000	CN2000	CN20	CN30	H01	G10	ST30A		ST20
APMT 0602PDFR-MA																		
060202PDSR-MM			•	•	•	•	•											
0602PDSR-MM			•	•	•	•	•	•										
060208PDSR-MM			•	•	•	•	•	•										
060212R-MM			•	•	•	•	•											
060216R-MM			•	•	•	•	•											

Комплектующие

Винт кассеты



Ключ



FTKA01842

TW06S-A

AMS1500S

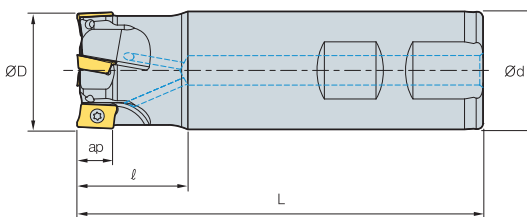

AA 90°

- AR : 7.5°~12.5°
- RR : -28°~-14°

(MM)

Обозначение		ØD	Ød	ℓ	L	ap	
AMS 15010HS	1	10	10	25	80	9	0.04
15010HS-1L16	1	10	16	30	160	9	0.21
15012HS	1	12	16	25	80	9	0.10
15012HS-1L16	1	12	16	30	160	9	0.21
15013HS	1	13	16	25	80	9	0.10
15014HS	1	14	16	25	80	9	0.10
15014HS-1L16	1	14	16	30	160	9	0.21
15016HS	2	16	16	30	90	9	0.11
15016HS-2L16	2	16	16	30	160	9	0.21
15017HS	2	17	16	30	90	9	0.12
15017HS-2L16	2	17	16	30	160	9	0.21
15018HS	2	18	16	30	90	9	0.14
15018HS-2L16	2	18	16	30	160	9	0.21
15019HS	2	19	16	30	90	9	0.16
15020HS	2	20	20	30	90	9	0.18
15020HS-2L20	2	20	20	30	160	9	0.34
15020HS-3	3	20	20	30	90	9	0.18
15021HS	2	21	20	30	90	9	0.20
15021HS-2L20	2	21	20	30	160	9	0.34
15021HS-3	3	21	20	30	90	9	0.2
15022HS	3	22	20	30	110	9	0.23
15022HS-3L20	3	22	20	30	180	9	0.38
15024HS	3	24	20	30	110	9	0.30
15024HS-4	4	24	20	30	110	9	0.3
15025HS-3S20	3	25	20	30	110	9	0.35
15025HS	3	25	25	30	110	9	0.35
15025HS-3L25	3	25	25	30	180	9	0.59

Применяемые СМП

Обозначение	APMT-MA				APMT-ML				APMT-MM			Стр.						
	NCM325	NCM335	NC5330	PC3500	PC5300	PC5400	PC3545	PC9530	PC6510	PD2000	Кермет		Тв. сплав					
											CN2000	CN20	CN30	H01	G10	ST30A	ST20	
APMT 0903PDFR-MA																		
0903PDER-ML																		
0903PDSR-MM			●	●	●	●	●											
090308PDSR-MM			●	●	●	●	●											
090312R-MM				●	●	●	●											
090316R-MM				●	●	●	●											
090320R-MM				●	●	●	●											

Комплектующие

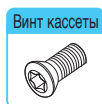

FTKA02555S
FTKA02565S



TW08S



Ø10~Ø14
Ø16~Ø100

AMS1500S

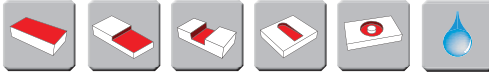
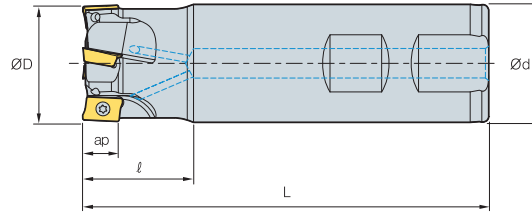

AA
90°
• AR : 7.5°~12.5°
• RR : -28°~-14°

(MM)

Обозначение		ØD	Ød	ℓ	L	ap	
AMS 15025HS-4S20	4	25	20	30	110	9	0.25
15025HS-4S25	4	25	25	30	110	9	0.25
15028HS	4	28	25	30	110	9	0.36
15028HS-4L25	4	28	25	30	180	9	0.61
15028HS-5	5	28	25	30	110	9	0.36
15030HS	4	30	25	30	110	9	0.38
15030HS-4L25	4	30	25	30	180	9	0.62
15030HS-5	5	30	25	30	110	9	0.38
15032HS	4	32	32	30	110	9	0.60
15032HS-4L32	4	32	32	30	180	9	1.00
15032HS-5	5	32	32	30	110	9	0.6
15035HS	5	35	32	30	110	9	0.70
15035HS-6	6	35	32	30	110	9	0.7
15040HS-S32	5	40	32	35	130	9	0.80
15040HS-5L32	5	40	32	35	200	9	1.20
15040HS-6S32	6	40	32	35	130	9	0.8
15040HS-S40	5	40	40	35	130	9	1.13
15040HS-6S40	6	40	40	35	130	9	1.13
15040HS-S42	5	40	42	35	130	9	1.23
15040HS-6S42	6	40	42	35	130	9	1.23

Применяемые СМП

Обозначение	APMT-MA		APMT-ML							APMT-MM			Стр.				
			Тв. сплав с покрытием							Кермет				Тв. сплав			
	NCM325	NCM335	NC5330	PC3500	PC5300	PC5400	PC3545	PC9530	PC6510	PD2000	CN2000	CN20	CN30	H01	G10	ST30A	ST20
APMT 0903PDFR-MA																	
0903PDER-ML							●										
0903PDSR-MM			●	●	●	●	●										
090308PDSR-MM			●	●	●	●	●										
090312R-MM				●	●	●	●										
090316R-MM				●	●	●	●										
090320R-MM				●	●	●	●										

Комплектующие

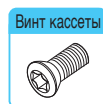

FTKA02565S

TW08S

AMS2000S

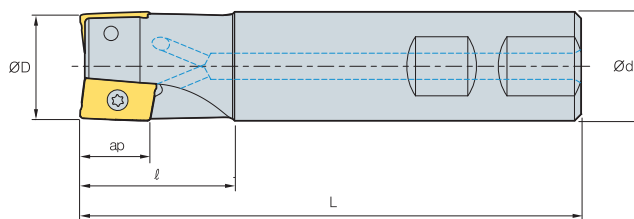

• AR : 3°~14°
• RR : -25°~18°

(MM)

Обозначение		ØD	Ød	ℓ	L	ap	
AMS 2010HS	1	10	10	20	85	11	0.04
2010HS-1L16	1	10	16	30	160	11	0.21
2012HS	1	12	16	25	85	11	0.10
2012HS-1L16	1	12	16	30	160	11	0.21
2014HS	1	14	16	25	90	11	0.12
2014HS-1L16	1	14	16	30	160	11	0.21
2016HS	2	16	16	25	90	11	0.12
2016HS-2L16	2	16	16	30	180	11	0.21
2018HS	2	18	16	25	90	11	0.12
2018HS-2L16	2	18	16	30	180	11	0.21
2020HS	2	20	20	30	100	11	0.21
2020HS-2L20	2	20	20	30	210	11	0.49
2022HS	3	22	20	35	115	11	0.25
2022HS-3L20	3	22	20	35	180	11	0.38
2025HS	3	25	25	35	115	11	0.40
2025HS-3L25	3	25	25	40	180	11	0.59
2032HS	4	32	32	40	125	11	0.70
2032HS-4L32	4	32	32	50	180	11	1.00
2040HS	5	40	32	42	130	11	0.84
2040HS-5L32	5	40	32	50	200	11	1.20
2040HS-S40	5	40	40	42	130	11	1.15
2040HS-S42	5	40	42	42	130	11	2.00
2050HS	6	50	32	45	135	11	1.06
2050HS-S40	6	50	40	45	135	11	1.38
2050HS-S42	6	50	42	45	135	11	1.50
2063HS	8	63	32	45	135	11	1.31
2063HS-S40	8	63	40	45	135	11	1.62
2063HS-S42	8	63	42	45	135	11	1.70

Применяемые СМП

APMT-MA

APMT-ML

APMT-MF

APMT-MM



Обозначение	Тв. сплав с покрытием								Кермет			Тв. сплав				Стр.		
	NCM325	NCM335	NC5330	PC3500	PC5300	PC5400	PC3545	PC9530	PC6510	PD2000	CN2000	CN20	CN30	H01	G10		ST30A	ST20
APMT 11T3PDR-MA																		
11T3PDR-ML																		
11T3PDR-MM	●		●	●	●	●	●	●	●									
11T3PDR-MF	●		●	●	●	●	●	●	●									
11T308PDR-MM	●		●	●	●	●	●	●	●									
11T312PDR-MM	●		●	●	●	●	●	●	●									
11T316R-MM	●		●	●	●	●	●	●	●									
11T318R-MM			●	●	●	●	●	●	●									
11T324R-MM			●	●	●	●	●	●	●									

Комплектующие



FTKA02555S
FTKA02565S



TW08S



Ø10~Ø14
Ø16~Ø100

AMS3000S

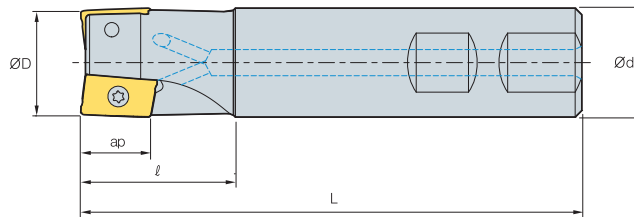

• AR : 3°~14°
• RR : -18°~10°

(MM)

Обозначение		ØD	ød	ℓ	L	ap	
AMS 3025HS	2	25	25	35	115	16	0.40
3025HS-2M25	2	25	25	35	180	16	0.65
3025HS-2L25	2	25	25	60	220	16	0.75
3032HS	3	32	32	40	125	16	0.69
3032HS-2M32	2	32	32	40	200	16	1.13
3032HS-2L32	2	32	32	65	260	16	1.52
3032HS-3M32	3	32	32	40	200	16	1.12
3032HS-3L32	3	32	32	65	260	16	1.48
3040HS	4	40	32	42	130	16	0.80
3040HS-3M32	3	40	32	42	200	16	1.24
3040HS-3L32	3	40	32	42	260	16	1.61
3040HS-4M32	4	40	32	42	200	16	1.21
3040HS-4L32	4	40	32	42	260	16	1.58
3040HS-S40	4	40	40	42	130	16	1.10
3040HS-S42	4	40	42	42	130	16	1.20
3050HS	5	50	32	45	135	16	1.00
3050HS-S40	5	50	40	45	135	16	1.30
3050HS-S42	5	50	42	45	135	16	1.40
3063HS	6	63	32	45	135	16	1.25
3063HS-S40	6	63	40	45	135	16	1.50
3063HS-S42	6	63	42	45	135	16	1.54

Применяемые СМП

	APMT-MA	APMT-ML	APMT-MF	APMT-MM														
Обозначение	Тв. сплав с покрытием								Кермет			Тв. сплав				Стр.		
	NCM325	NCM335	NC5330	PC3500	PC5300	PC5400	PC3545	PC9530	PC6510	PD2000	CN2000	CN20	CN30	H01	G10		ST30A	ST20
APMT 1604PDFR-MA																		E05
1604PDER-ML																		
1604PDSR-MM	●		●	●	●	●	●	●										
1604PDSR-MF	●		●	●	●	●	●	●										
160410PDSR-MM	●		●	●	●	●	●	●										
160416PDSR-MM	●		●	●	●	●	●	●										
160424R-MM			●	●	●	●	●	●										
160430R-MM			●	●	●	●	●	●										
160432R-MM	●		●	●	●	●	●	●										

Комплектующие

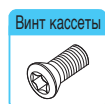

FTKA0408
FTKA0410



TW15S



Ø25
Ø32~Ø100

AMS3000S-K

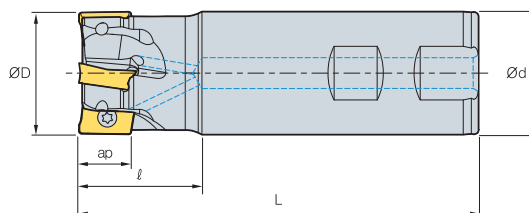

(MM)

Обозначение		ØD	ød	ℓ	L	ap	
AMS 3025HS-K	2	25	25	35	115	16	0.4
3032HS-K	3	32	32	40	125	16	0.69
3040HS-K	4	40	32	42	130	16	0.8
3040HS-K-S40	4	40	40	42	130	16	1.1
3040HS-K-S42	4	40	42	42	130	16	1.2
3050HS-K	5	50	32	45	135	16	1.0
3050HS-K-S40	5	50	40	45	135	16	1.3
3050HS-K-S42	5	50	42	45	135	16	1.4
3063HS-K	6	63	32	45	135	16	1.25
3063HS-K-S40	6	63	40	45	135	16	1.5
3063HS-K-S42	6	63	42	45	135	16	1.54

Применяемые СМП

APFT-X22 APFT-X28 APKT APKT-MF APKT-MM APKT-MM1 APKT-MA APKT-MA2 APKT-MA3 APKT-X22 APKT-X23 APKT-X24



Обозначение	Тв. сплав с покрытием								Кермет			Тв. сплав				Стр.	
	NCM325	NCM335	NC5330	PC3500	PC5300	PC3545	PC9530	PC6510	PC215K	PD2000	CN2000	CN20	CN30	H01	G10		ST30A
APFT 1604PDSR-X22				●													
1604PDTR-X22																	
1604PDR-X28																	
1604PDSR-X28																	
1604PDTR-X28																	
APKT 1604PDSR	●			●				●									
1604PDSR-MF	●				●												
1604PDSR-MM	●	●		●	●	●	●	●									
160432R-MM1	●																
1604PDFR-MA														●			
1604PDFR-MA2																	
160416FR-MA2																	
160432FR-MA2																	
1604PDFR-MA3														●	●		
1604PDSR-X22	●																
1604PDTR-X22																	
1604PDR-X23																	
1604PDTR-X23																	
1604PDR-X24																	
1604PDTR-X24																	

Комплектующие

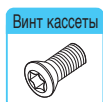

ФТКА0408
ФТКА0410

TW15S

Ø25
Ø32~Ø100

AMS4000S

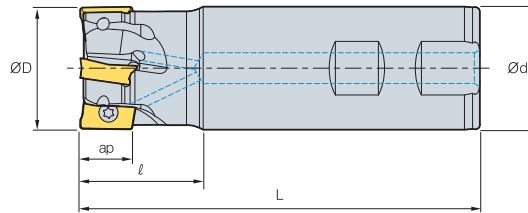

AA
90°
• AR : 7°~13°
• RR : -20°~6°

(MM)

Обозначение		$\varnothing D$	$\varnothing d$	ϱ	L	ap	
AMS 4020HS	1	20	20	30	90	17	0.18
4020HS-M	1	20	20	30	160	17	0.17
4021HS	1	21	20	30	90	17	0.19
4021HS-M	1	21	20	30	160	17	0.34
4025HS	2	25	25	40	110	17	0.35
4025HS-2M25	2	25	25	40	180	17	0.58
4025HS-2L25	2	25	25	40	230	17	0.8
4026HS	2	26	25	40	110	17	0.37
4026HS-2M25	2	26	25	40	180	17	0.60
4026HS-2L25	2	26	25	40	230	17	0.82
4032HS	3	32	32	40	125	17	0.65
4032HS-2M32	2	32	32	50	200	17	1.17
4032HS-2L32	2	32	32	50	260	17	1.5
4032HS-3M32	3	32	32	50	200	17	1.10
4032HS-3L32	3	32	32	50	260	17	1.48
4033HS	3	33	32	40	125	17	0.68
4033HS-2M32	2	33	32	50	200	17	1.12
4033HS-2L32	2	33	32	50	260	17	1.55
4033HS-3M32	3	33	32	50	200	17	1.12
4033HS-3L32	3	33	32	50	260	17	1.55

Применяемые СМП

APMT-MA



APMT-ML



APMT-MM



APMT-MF



Обозначение	Тв. сплав с покрытием								Кермет			Тв. сплав				Стр.		
	NCM325	NCM335	NC5330	PC3500	PC5300	PC5400	PC3545	PC9530	PC6510	PD2000	CN2000	CN20	CN30	H01	G10		ST30A	ST20
APMT 1806PDFR-MA																		
1806PDER-ML																		
1806PDSR-MM	•		•	•	•	•	•	•	•									
1806PDSR-MF			•		•	•	•											
180612PDSR-MM	•		•		•	•	•											
180616PDSR-MM			•		•	•	•											
180620PDSR-MM			•	•		•	•											
180624PDSR-MM			•	•		•	•											
180630R-MM			•	•		•	•											
180632R-MM			•	•		•	•											

Комплектующие

Винт кассеты

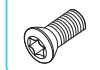

Ключ



Диаметр фрезы, мм



FTKA0408
FTKA0410

TW15S

$\varnothing 20 \sim \varnothing 25$
 $\varnothing 32 \sim \varnothing 100$

AMS4000S

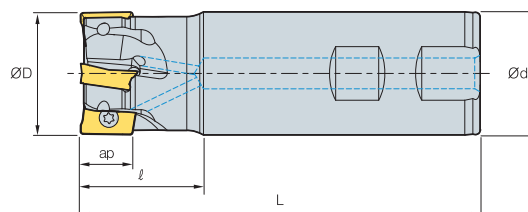

• AR : 7°~13°
• RR : -20°~-6°

(mm)

Обозначение		ØD	Ød	ℓ	L	ap	
AMS 4040HS-3M32	3	40	32	50	200	17	1.20
4040HS-3L32	3	40	32	50	260	17	1.60
4040HS-4M32	4	40	32	50	200	17	1.20
4040HS-4L32	4	40	32	50	260	17	1.60
4040HS-S32	4	40	32	40	130	17	0.76
4040HS-S40	4	40	40	40	130	17	1.10
4040HS-S42	4	40	42	40	130	17	1.20
4050HS-S32	5	50	32	40	135	17	0.95
4050HS-S40	5	50	40	40	135	17	1.30
4050HS-S42	5	50	42	40	135	17	1.40
4063HS-S32	6	63	32	40	135	17	1.25
4063HS-S40	6	63	40	40	135	17	1.60
4063HS-S42	6	63	42	40	135	17	1.70

Применяемые СМП

APMT-MA

APMT-ML

APMT-MM

APMT-MF

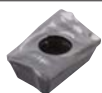

Обозначение	Тв. сплав с покрытием								Кермет			Тв. сплав				Стр.	
	NCM325	NCM335	NC5330	PC3500	PC5300	PC5400	PC3545	PC9530	PC6510	PD2000	CN2000	CN20	CN30	H01	G10		ST30A
APMT 1806PDR-MA																	
1806PDR-ML																	
1806PDR-MM	●		●	●	●	●	●	●	●								
1806PDR-MF			●	●	●	●	●										
180612PDR-MM	●		●	●	●	●	●										
180616PDR-MM			●			●	●										
180620PDR-MM																	
180624PDR-MM			●	●		●											
180630R-MM																	
180632R-MM			●	●		●	●										

Комплектующие

Винт кассеты



Ключ



FTKA0410

TW15S

AMS1000SE/2000SE

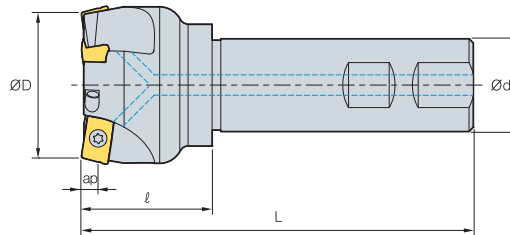

• AR : -4.5°~-1°
• RR : -3°~0°

(MM)

Обозначение		ØD	Ød	l	L	ap	kg
AMS 1025HSE	3	25	25	30	115	2.5	0.41
AMS 2025HSE	2	25	25	30	115	4	0.4
2032HSE	3	32	32	40	125	4	0.72
2040HSE	3	40	32	40	130	4	0.86
2040HSE-S40	3	40	40	40	130	4	1.2
2040HSE-S42	3	40	42	40	130	4	1.3
2050HSE	4	50	32	40	135	4	0.98
2050HSE-S40	4	50	40	40	135	4	1.3
2050HSE-S42	4	50	42	40	135	4	1.4
2063HSE	5	63	32	40	135	4	1.24
2063HSE-S40	5	63	40	40	135	4	1.57
2063HSE-S42	5	63	42	40	135	4	1.62

Применяемые СМП

APMT-MF

APMT-MM



Тип	Обозначение	Тв. сплав с покрытием								Кермет			Тв. сплав				Стр.	
		NCM825	NCM835	NC5330	PC3500	PC5300	PC5400	PC3545	PC9530	PC6510	PD2000	CN2000	CN20	CN30	H01	G10		ST30A
1000 Тип	APMT 060202PDSR-MM			●	●	●	●	●										
	0602PDSR-MM			●	●	●	●	●	●									
	060208PDSR-MM			●	●	●	●	●										
	060212R-MM			●	●	●												
	060216R-MM				●													
2000 Тип	APMT 11T3PDSR-MM	●		●	●	●	●	●	●									
	11T3PDSR-MF	●		●	●	●	●	●										
	11T308PDSR-MM	●		●	●	●	●	●	●									
	11T312PDSR-MM	●		●	●	●	●	●	●									
	11T316R-MM	●		●	●	●	●	●										
	11T318R-MM			●	●	●	●	●										
	11T324R-MM			●	●	●	●	●										
	APXT 11T3PDSR-MR																	
	11T308PDR-MR																	
	11T3PDR-MA														●			
11T318R-MA																		

Комплектующие

Винт кассеты



Ключ



Ключ



1000 Тип	FTKA01842	-	TW06S-A
2000 Тип	FTKA02565S	TW08S	-

AMS3000SE

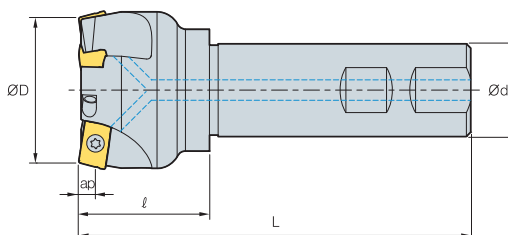

• AR : -4.5°~1°
• RR : -3°~0°

(mm)

Обозначение		ØD	Ød	ℓ	L	ap	
AMS 3050HSE	3	50	32	45	135	6	1.0
3050HSE-S40	3	50	40	45	135	6	1.3
3050HSE-S42	3	50	42	45	135	6	1.4
3063HSE	4	63	32	45	135	6	1.3
3063HSE-S40	4	63	40	45	135	6	1.6
3063HSE-S42	4	63	42	45	135	6	1.7

Применяемые СМП

APMT-MF

APMT-MM



Обозначение	Тв. сплав с покрытием									Кермет			Тв. сплав				Стр.	
	NCM325	NCM335	NC5330	PC3500	PC5300	PC5400	PC3545	PC9530	PC6510	PD2000	CN2000	CN20	CN30	H01	G10	ST30A		ST20
APMT 1604PDSR-MM	●		●	●	●	●	●	●	●									E05
1604PDSR-MF	●		●	●	●	●	●	●	●									
160410PDSR-MM	●		●	●	●	●	●	●	●									
160416PDSR-MM	●		●	●	●	●	●	●	●									
160424R-MM			●	●	●	●	●	●	●									
160430R-MM					●	●	●	●	●									
160432R-MM	●		●	●	●	●	●	●	●									

Комплектующие

Винт кассеты



Ключ



ФТКА0410

TW15S



AMS1000M/1500M

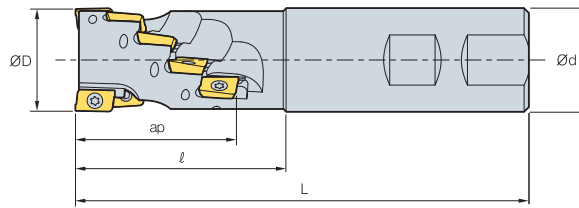

AA
90°
• AR : 7°~9°
• RR : -13°~10°

(MM)

Обозначение		øD	ød	l	L	Количество зубьев	ap	kg
AMS	1016M	6	16	16	30	2	15.5	0.3
	1020M	12	20	20	32	3	20.5	0.3
	1025M	20	25	25	39	4	25.5	0.3
AMS	15020M	3	20	20	42	1	26.5	0.3
	15025M	8	25	25	50	2	35	0.3
	15032M	10	32	32	60	2	44	0.3

Применяемые СМП

Тип	Обозначение	Тв. сплав с покрытием										Кермет			Тв. сплав		Стр.	
		NCM325	NCM335	NC5330	PC3500	PC5300	PC5400	PC3545	PC9530	PC6510	PD2000	CN2000	CN20	CN30	H01	G10		ST30A
1000 Тип	APMT 0602PDFR-MA																	
	060202PDSR-MM			•	•	•	•	•										
	0602PDSR-MM			•	•	•	•	•	•	•								
	060208PDSR-MM			•	•	•	•	•										
	060212R-MM			•	•	•												
	060216R-MM				•													
1500 Тип	APMT 0903PDFR-MA																	
	0903PDER-ML							•										
	0903PDSR-MM			•	•	•	•	•										
	090308PDSR-MM			•	•	•	•	•										
	090312R-MM					•	•	•										
	090316R-MM					•	•											
	090320R-MM					•	•											

Рекомендации по выбору СМП

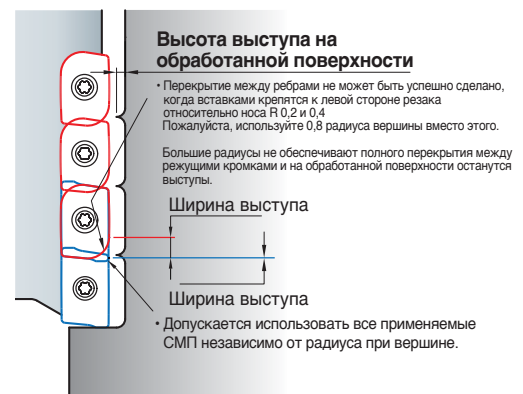

Комплектующие

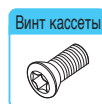

Винт кассеты



Ключ



Ключ

1000 Тип	FTKA01842	-	TW06S-A
1500 Тип	FTKA02565S	TW08S	-



AMS2000M/4000M

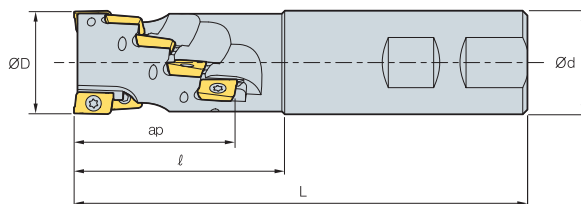

AA
90°
• AR : 7°~9°
• RR : -13°~-10°

Обозначение		øD	ød	l	L	Количество зувьев	ap	
AMS 2020M	3	20	20	45	120	1	29.4	0.32
	8	25	25	55	130	2	38.9	0.40
	10	32	32	65	140	2	48.5	0.65
	14	40	40	75	150	2	58	0.75
AMS 4032M	4	32	32	60	130	2	31.6	0.65
	6	40	40	70	140	2	46	1.11
	6	50	40	55	125	2	46	1.22
	8	50	40	70	140	2	61	1.37

Применяемые СМП

APMT-MF

APMT-MM



Тип	Обозначение	Тв. сплав с покрытием								Кермет			Тв. сплав				Стр.	
		NCM325	NCM335	NC5330	PC3500	PC5300	PC5400	PC3545	PC9530	PC6510	PD2000	CN2000	CN20	CN30	H01	G10		ST30A
2000 Тип	APMT 11T3PDFR-MA																	
	11T3PDER-ML																	
	11T3PDSR-MM	•		•	•	•	•	•	•									
	11T3PDSR-MF	•		•	•	•	•	•	•									
	11T308PDSR-MM	•		•	•	•	•	•	•									
	11T312PDSR-MM	•		•	•	•	•	•	•									
	11T316R-MM	•		•	•	•	•	•	•									
	11T318R-MM																	
4000 Тип	APMT 1806PDFR-MA																	
	1806PDER-ML																	
	1806PDSR-MM	•		•	•	•	•	•	•									
	1806PDSR-MF	•		•	•	•	•	•	•									
	180612PDSR-MM	•		•	•	•	•	•	•									
	180616PDSR-MM			•	•	•	•	•	•									
	180620PDSR-MM																	
	180624PDSR-MM			•	•	•	•	•	•									
	180630R-MM																	
	180632R-MM			•	•	•	•	•	•									

Рекомендации по выбору СМП



Комплектующие

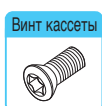

2000 Тип	FTKA02565S	TW08S
4000 Тип	FTKA0410	TW15S

Применяемые СМП E05

• : Наличие на складе

AMS1000MH/1500MH/2000MH/3000MH



Рис. 1



Рис. 2

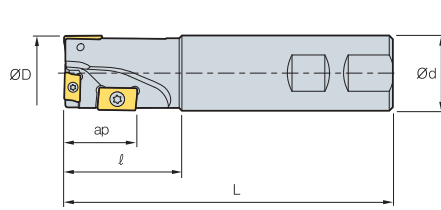

AA
90°
• AR : 9°~12°
• RR : -12°~10°

(мм)

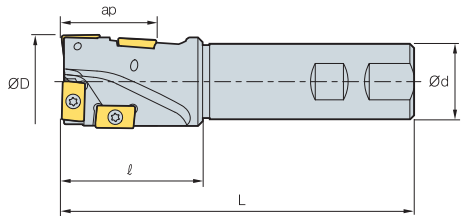
Обозначение		ØD	Ød	l	L	ap		APMT 0602-	APMT 0903-	APMT 11T3-	APMT 1604-	APKT 1604-	Рис.
AMS 1014MH	3	14	12	30	120	11	0.16	3	-	-	-	-	1
AMS 1016MH	3	16	14	30	140	11	0.20	3	-	-	-	-	1
AMS 1018MH	3	18	16	30	140	11	0.21	3	-	-	-	-	1
AMS 15020MH	3	20	20	35	140	17	0.31	1	2	-	-	-	1
AMS 2025MH	3	25	25	40	130	20	0.45	-	-	3	-	-	1
AMS 2032MH	3	32	32	50	140	30	0.75	-	-	1	2	-	1
AMS 3040MH-K	4	40	32	60	150	40	0.90	-	-	-	-	4	2

Применяемые СМП

		APKT-MF	APKT-MM	APMT-MA	APMT-ML	APMT-MF	APMT-MM	APXT-MA										
Тип	Обозначение	Тв. сплав с покрытием								Кермет			Тв. сплав		Стр.			
		NCM325	NCM335	NC5330	PC3500	PC5300	PC5400	PC3545	PC9630	PC6510	PD2000	CN2000	CN20	CN30		H01	G10	ST30A
1000 Тип	APMT 0602PDR-MA																	
	060202PDSR-MM			•	•	•	•	•										
	0602PDSR-MM			•	•	•	•	•	•									
	060208PDSR-MM			•	•	•	•	•										
1500 Тип	APMT 0903PDR-MA																	
	0903PDR-ML						•											
	0903PDSR-MM			•	•	•	•	•										
	090308PDSR-MM			•	•	•	•	•										
2000 Тип	APMT 11T3PDR-MA																	
	11T3PDR-ML						•											
	11T3PDSR-MM	•		•	•	•	•	•	•									
	11T3PDSR-MF	•		•	•	•	•	•										
	11T308PDSR-MM	•		•	•	•	•	•	•									
	11T312PDSR-MM	•		•	•	•	•	•										
	11T316R-MM	•		•	•	•	•	•										
	11T318R-MM	•		•	•	•	•	•										
3000 Тип	APMT 1604PDSR-MM	•		•	•	•	•	•	•									
	1604PDSR-MF	•		•	•	•	•	•	•									
3000-K Тип	APKT 1604PDSR-MM	•	•	•	•	•	•	•	•									
	1604PDSR-MF	•		•	•	•	•	•	•									

Рекомендуемые режимы резания

Комплектующие



Тип	Винт кассеты	Ключ	Ключ
1000 Тип	FTKA01842	-	TW06S-A
1500 Тип	FTKA02565S	TW08S	-
2000 Тип	FTKA02565S	TW08S	-
3000 Тип	FTKA0410	TW15S	-



	Сверление	Обработка уступов	Обработка пазов
Vp, м/мин	80~200	80~200	80~200
Sz, мм/зуб	0.03~0.06	0.05~0.25	0.05~0.20

• Пожалуйста, храните глубины сверления ниже 0.25D, когда вы бурения
• Пожалуйста, держите шаг глубиной от 0,2 до 0,3 мм

AMM1000

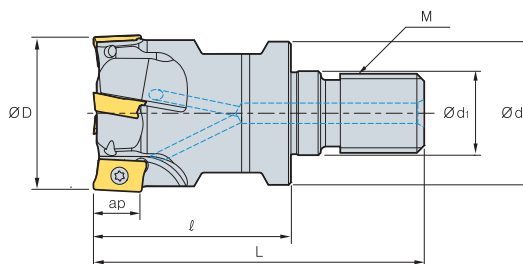

AA 90°
 • AR : 7.5°~12.5°
 • RR : -28°~6°

(мм)

Обозначение		ØD	Ød	Ød1	ℓ	L	M	ap	
AMM 1012HR-M06	3	12	11	6.5	25	40	M06	5.6	0.02
1016HR-M08	4	16	14.5	8.5	25	42	M08	5.6	0.03
1020HR-M10	5	20	18	10.5	30	51	M10	5.6	0.07
1025HR-M12	7	25	23	12.5	35	59	M12	5.6	0.12
1032HR-M16	8	32	29	17	40	67	M16	5.6	0.23

Применяемые СМП

APMT-MA



APMT-MM



Обозначение	Тв. сплав с покрытием								Кермет			Тв. сплав				Стр.	
	NCM325	NCM335	NC5330	PC3500	PC3300	PC5400	PC3545	PC9530	PC6510	PD2000	CN2000	CN20	CN30	H01	G10		ST30A
APMT 0602PDFR-MA																	
060202PDSR-MM			●	●	●	●	●										
0602PDSR-MM			●	●	●	●	●	●									
060208PDSR-MM			●	●	●	●	●										
060212R-MM			●	●	●												
060216R-MM			●	●													

Применяемые оправки

Обозначение	Применяемые оправки
AMM 1012HR-M06	MAT - M06
1016HR-M08	MAT - M08
1020HR-M10	MAT - M10
1025HR-M12	MAT - M12
1032HR-M16	MAT - M16

Обозначение : AMM1032HR-M16
 Фрезерная головка с резьбой(M16)

II

Оправка : MAT-M16-035-S32S
 Присоединительная резьба(M16)

Комплектующие

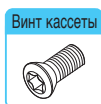

Винт кассеты



Ключ

FTKA01842

TW06S-A

AMM1500

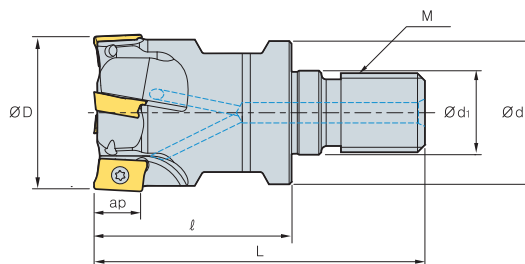

• AR : 7.5°~12.5°
• RR : -28°~6°

(мм)

Обозначение		$\varnothing D$	$\varnothing d$	$\varnothing d_1$	ℓ	L	M	ap	
AMM 15010HR-M06	1	10	9.5	6.5	25	40	M06	9	0.01
15012HR-M06	1	12	11	6.5	25	40	M06	9	0.02
15016HR-M08	2	16	14.5	8.5	25	42	M08	9	0.03
15020HR-M10	2	20	18	10.5	30	51	M10	9	0.06
15025HR-M12	3	25	23	12.5	35	59	M12	9	0.12
15032HR-M16	4	32	29	17	40	67	M16	9	0.22

Применяемые СМП

Обозначение	APMT-MA				APMT-ML				APMT-MM				Стр.						
	NCM325	NCM335	NC5330	PC3500	PC5300	PC5400	PC3545	PC9530	PC6510	PD2000	Кермет	Тв. сплав							
											CN2000	CN20	CN30	H01	G10	ST30A	ST20		
APMT 0903PDFR-MA																			E05
0903PDER-ML																			
0903PDSR-MM			•	•	•	•	•												
090308PDSR-MM			•	•	•	•	•												
090312R-MM						•	•												
090316R-MM				•	•														
090320R-MM				•	•														

Применяемые оправки

Обозначение	Применяемые оправки
AMM 15010HR-M06	MAT - M06
15012HR-M06	
15016HR-M08	
15020HR-M10	
15025HR-M12	
15032HR-M16	

Обозначение : AMM1032HR-M16
Фрезерная головка с резьбой(M16)

II

Оправка : MAT-M16-035-S32S
Присоединительная резьба(M16)

Комплектующие

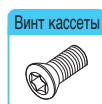

FTKA02555S
FTKA02565S



TW08S



$\varnothing 10 \sim \varnothing 14$
 $\varnothing 16 \sim \varnothing 100$

AMM2000

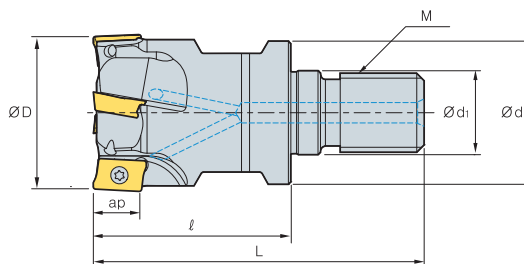

Обозначение		$\varnothing D$	$\varnothing d$	$\varnothing d_1$	ℓ	L	M	ap	
AMM 2016HR-M08	2	16	14.5	8.5	25	42	M08	11	0.04
2020HR-M10	2	20	18	10.5	30	51	M10	11	0.07
2025HR-M12	3	25	23	12.5	35	59	M12	11	0.04
2032HR-M16	4	32	29	17	40	67	M16	11	0.23
2040HR-M16	5	40	29	17	40	67	M16	11	0.25

Применяемые СМП

Обозначение	APMT-MA		APMT-ML		APMT-MM		APMT-MF		APXT-MA		Стр.							
	NCM325	NCM335	NC5330	PC3500	PC5300	PC5400	PC5545	PC9530	PC6510	PD2000		Кермет	Тв. сплав					
											CN2000	CN20	CN30	H01	G10	ST30A	ST20	
APMT 11T3PDFR-MA																		
11T3PDER-ML																		
11T3PDSR-MM	●		●	●	●	●	●	●	●									
11T3PDSR-MF	●		●	●	●	●	●	●	●									
11T308PDSR-MM	●		●	●	●	●	●	●	●									
11T312PDSR-MM	●		●	●	●	●	●	●	●									
11T316R-MM	●		●	●	●	●	●	●	●									
11T318R-MM																		
11T324R-MM			●	●	●		●											
APXT 11T3PDR-MA														●				

Применяемые оправки

Обозначение	Применяемые оправки
AMM 2016HR-M08	MAT - M08
2020HR-M10	MAT - M10
2025HR-M12	MAT - M12
2032HR-M16	MAT - M16
2040HR-M16	MAT - M16

Обозначение : AMM1032HR-M16
 Фрезерная головка с резьбой(M16)

II

Оправка : MAT-M16-035-S32S
 Присоединительная резьба(M16)

Комплектующие

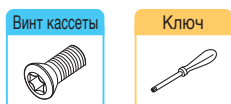

FTKA02565S TW08S

Гарантия сильным сдерживать силы на 2 стороны ограничивают

Фрезы с хвостовиком BT/HSK

Система обозначения фрез

BT50 NAT 4 063 114 - 4 F

Тип хвостовика	Тип рабочей части	Тип	Диаметр	Длина	Число зубьев	Длина рабочей части или полная длина
BT30/40/50 HSK40/50/63/100	AM NAT RM	1000 Тип 1500 Тип 2000 Тип 3000 Тип 4000 Тип	063 : Ø63	Длина : 114 HS : подвод СОЖ	Число зубьев : 4	Неуказанно : Стандарт Y : F No code : No L : Удлиненный тип

Система обозначения оправок

BT50 NAT M16 092

Тип хвостовика	Тип	Диаметр резьбы	Общая длина
BT30/40/50 HSK40/50/63/100	NAT	M16	092 : 92

Хвостовики DBT

Общие характеристики хвостовиков DBT

- ▶ Высокая жесткость закрепления за счет базирования по направляющей и опорной базам.
- ▶ Возможность применения повышенных частот вращения.
- ▶ Обеспечение высокого качества обработанной поверхности.

DBT	Сравнительный анализ шероховатости обработанных поверхностей	BT
2-е Поверхности базирования		одна поверхность базирования
	DBT Обрабатываемые материалы Ra = 0.3µm	
		BT Обрабатываемые материалы Ra = 0.5µm

Хвостовики HSK

Общие характеристики хвостовиков HSK

- ▶ Высокая жесткость закрепления за счет базирования по направляющей и опорной базам.
- ▶ Сохранение высокой жесткости при высокой частоте вращения.
- ▶ Обеспечение высокого качества обработанной поверхности.
- ▶ Высокая точность позиционирования в осевом и радиальном направлении.

Сравнительный анализ точности обработки для хвостовиков HSK A и HSK T



Результаты измерений

ТИП ХВОСТОВИКА	Минимальная точность.	Максимальная точность	Оборудование.
HSK-T	0.075	0.035	обрабатывающий центр
HSK-A	0.33	0.08 общий	МСТ



BT30 AM1000HS / BT40 AM1500HS

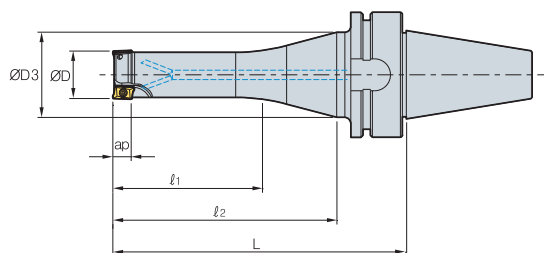

(мм)

Обозначение		ØD	ØD ₃	l ₁	l ₂	L	ap	
BT30	AM1010HS-2	2	10	43	35	83	112	5.6
	AM1012HS-2	2	12	43	35	83	112	5.6
	AM1012HS-3	3	12	43	35	83	112	5.6
	AM1016HS-3	3	16	43	35	83	112	5.6
	AM1016HS-4	4	16	43	35	83	112	5.6
	AM1020HS-4	4	20	43	45	98	127	5.6
	AM1020HS-5	5	20	43	45	98	127	5.6
BT40	AM15016HS-2	2	16	43	45	83	117	9
	AM15016HS-2L	2	16	43	35	118	152	9
	AM15020HS-2	2	20	43	60	98	132	9
	AM15020HS-3	3	20	43	60	98	132	9
	AM15020HS-2L	2	20	43	50	118	152	9
	AM15025HS-3	3	25	43	75	113	147	9
	AM15025HS-4	4	25	43	75	113	147	9
	AM15025HS-3L	3	25	43	65	133	167	9
	AM15032HS-4	4	32	43	80	113	147	9
	AM15032HS-5	5	32	43	80	113	147	9
	AM15032HS-4L	4	32	43	70	133	167	9
	AM15040HS-5	5	40	47	60	98	132	9
	AM15040HS-6	6	40	47	60	98	132	9
	AM15040HS-5L	5	40	47	50	118	152	9

Применяемые СМП

Тип	Обозначение	Тв. сплав с покрытием										Кермет			Тв. сплав				Стр.	
		NCM325	NCM335	NC5330	PC3500	PC5300	PC5400	PC3545	PC9530	PC6510	PD2000	CN2000	CN20	CN30	H01	G10	ST30A	ST20		
1000 Тип	APMT 0602PDFR-MA																			E05
	060202PDSR-MM			•	•	•	•	•												
	0602PDSR-MM			•	•	•	•	•	•											
	060208PDSR-MM			•	•	•	•	•	•											
	060212R-MM			•	•	•														
060216R-MM				•																
1500 Тип	APMT 0903PDFR-MA																			
	0903PDER-ML							•												
	0903PDSR-MM			•	•	•	•	•	•											
	090308PDSR-MM			•	•	•	•	•	•											
	090312R-MM				•	•	•	•	•											
	090316R-MM				•	•	•	•	•											
	090320R-MM				•	•														

Комплектующие

Винт кассеты



Ключ



Ключ



Диаметр фрезы, мм



1000 Тип	FTKA01842	-	TW06S-A	Ø10~Ø63
1500 Тип	FTKA02565S	TW08S	-	Ø16~Ø100

BT40 AM2000HS

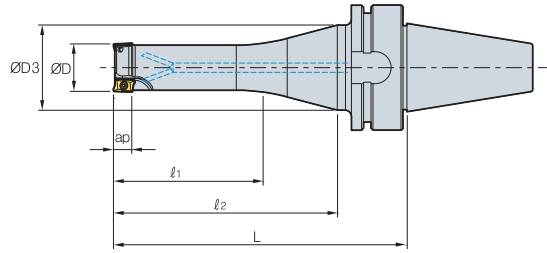

• AR : 7°~10°
• RR : -20°~7°

(мм)

Обозначение		$\varnothing D$	$\varnothing D_3$	ℓ_1	ℓ_2	L	a_p
BT40 AM2016HS-2	2	16	43	45	83	117	11
AM2016HS-2L	2	16	43	35	118	152	11
AM2020HS-2	2	20	43	60	98	132	11
AM2020HS-2L	2	20	43	50	118	152	11
AM2025HS-3	3	25	43	75	113	147	11
AM2025HS-3L	3	25	43	65	113	147	11
AM2032HS-4	4	32	43	80	113	147	11
AM2032HS-4L	4	32	43	70	133	167	11
AM2040HS-5	5	40	47	60	98	132	11
AM2040HS-5L	5	40	47	50	118	152	11
AM2050HS-6	6	50	47	60	98	132	11
AM2050HS-6L	6	50	47	50	118	152	11

Применяемые СМП

	APMT-MA		APMT-ML		APMT-MM		APMT-MF						Стр.				
Обозначение	Тв. сплав с покрытием								Кермет			Тв. сплав			Стр.		
	NCM325	NCM335	NC5330	PC3500	PC5300	PC5400	PC3545	PC9530	PC6510	PD2000	CN2000	CN20	CN30	H01		G10	ST30A
APMT 11T3PDFR-MA																	
11T3PDER-ML																	
11T3PDSR-MM	●		●	●	●	●	●	●									
11T3PDSR-MF	●		●	●	●	●	●	●									
11T308PDSR-MM	●		●	●	●	●	●	●									
11T312PDSR-MM	●		●	●	●	●	●	●									
11T316R-MM	●		●	●	●	●	●	●									
11T318R-MM																	
11T324R-MM			●	●	●		●										

Комплектующие

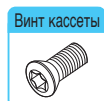

Винт кассеты



Ключ

FTKA02565S

TW08S



BT50 AM3000HS / AM4000HS

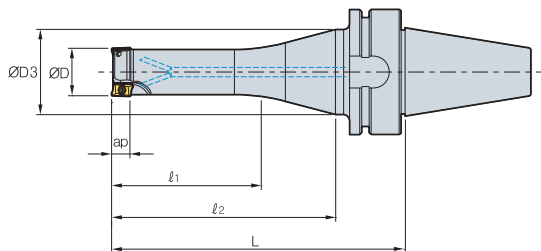

(мм)

Обозначение		$\varnothing D$	$\varnothing D_3$	l_1	l_2	L	a_p	
BT50	AM3025HS-2	2	25	43	65	113	158	16
	AM3025HS-2L	2	25	43	55	123	168	16
	AM3032HS-3	3	32	43	70	113	158	16
	AM3032HS-3L	3	32	43	60	123	168	16
	AM3040HS-4	4	40	47	50	98	143	16
	AM3040HS-4L	4	40	47	40	108	153	16
	AM3050HS-5	5	50	47	50	98	143	16
	AM3050HS-5L	5	50	47	40	108	153	16
BT50	AM4020HS-1	1	20	43	50	98	143	17
	AM4025HS-2	2	25	43	65	113	158	17
	AM4032HS-3	3	32	43	70	113	158	17
	AM4032HS-3L	3	32	43	60	123	168	17
	AM4040HS-4	4	40	47	50	98	143	17
	AM4040HS-4L	4	40	47	40	108	153	17
	AM4050HS-5	5	50	47	50	98	143	17
	AM4050HS-5L	5	50	47	40	108	153	17

Применяемые СМП

APMT-MA

APMT-ML

APMT-MM

APMT-MF



Тип	Обозначение	Тв. сплав с покрытием								Кермет			Тв. сплав				Стр.	
		NCM325	NCM335	NC5330	PC3500	PC5300	PC5400	PC3545	PC9530	PC6510	PD2000	CN2000	CN20	CN30	H01	G10		ST30A
3000 Тип	APMT 1604PDR-MA																	
	1604PDR-ML																	
	1604PDR-MM	●		●	●	●	●	●	●									
	1604PDR-MF	●		●	●	●	●	●	●									
	160410PDR-MM	●		●	●	●	●	●	●									
	160416PDR-MM	●		●	●	●	●	●	●									
	160424R-MM			●	●	●	●	●	●									
	160430R-MM			●	●	●	●	●	●									
4000 Тип	APMT 1806PDR-MM	●		●	●	●	●	●	●									
	1806PDR-MF	●		●	●	●	●	●	●									
	180612PDR-MM			●	●	●	●	●	●									
	180616PDR-MM	●		●	●	●	●	●	●									
	180620PDR-MM			●	●	●	●	●	●									
	180624PDR-MM			●	●	●	●	●	●									
	180630R-MM			●	●	●	●	●	●									
	180632R-MM			●	●	●	●	●	●									

Комплектующие

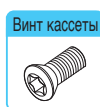

3000 Тип	ФТКА0408 ФТКА0410	TW15S	$\varnothing 25$ $\varnothing 32 \sim \varnothing 100$
4000 Тип	ФТКА0408 ФТКА0410	TW15S	$\varnothing 20 \sim \varnothing 25$ $\varnothing 32 \sim \varnothing 200$

HSK63A AM1000HS/1500HS

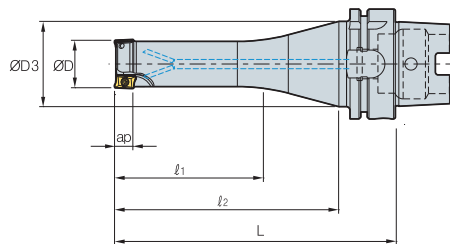

AA
90°
• AR : 7.5°~13°
• RR : -28°~-7°

(MM)

Обозначение		$\varnothing D$	$\varnothing D_3$	ℓ_1	ℓ_2	L	aD
HSK63A AM1010HS-2	2	10	43	35	83	116	5.6
AM1012HS-2	2	12	43	35	83	116	5.6
AM1012HS-3	3	12	43	35	83	116	5.6
AM1016HS-3	3	16	43	35	83	116	5.6
AM1016HS-4	4	16	43	35	83	116	5.6
AM1020HS-4	4	20	43	45	98	131	5.6
AM1020HS-5	5	20	43	45	98	131	5.6
HSK63A AM15016HS-2	2	16	43	45	83	116	9
AM15016HS-2L	2	16	43	35	118	151	9
AM15020HS-2	2	20	43	60	98	131	9
AM15020HS-3	3	20	43	60	98	131	9
AM15020HS-2L	2	20	43	50	118	151	9
AM15025HS-3	3	25	43	75	113	146	9
AM15025HS-4	4	25	43	75	113	146	9
AM15025HS-3L	3	25	43	65	133	166	9
AM15032HS-4	4	32	43	80	113	146	9
AM15032HS-5	5	32	43	80	113	146	9
AM15032HS-4L	4	32	43	70	133	166	9
AM15040HS-5	5	40	47	60	98	131	9
AM15040HS-6	6	40	47	60	98	131	9
AM15040HS-5L	5	40	47	50	118	151	9

Применяемые СМП

APMT-MA

APMT-ML

APMT-MM



Тип	Обозначение	Тв. сплав с покрытием								Кермет			Тв. сплав				Стр.	
		NCM325	NCM335	NC5330	PC3500	PC5300	PC5400	PC3545	PC9530	PC6510	PD2000	CN2000	CN20	CN30	H01	G10		ST30A
1000 Тип	APMT 0602PDFR-MA																	
	060202PDSR-MM			•	•	•	•	•	•									
	0602PDSR-MM			•	•	•	•	•	•									
	060208PDSR-MM			•	•	•	•	•	•									
	060212R-MM			•	•	•												
	060216R-MM				•													
1500 Тип	APMT 0903PDFR-MA																	
	0903PDER-ML							•										
	0903PDSR-MM			•	•	•	•	•	•									
	090308PDSR-MM			•	•	•	•	•	•									
	090312R-MM				•	•	•	•	•									
	090316R-MM				•	•												
	090320R-MM				•	•												

Комплектующие

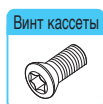

1000 Тип	FTKA01842	-	TW06S-A	$\varnothing 10 \sim \varnothing 63$
1500 Тип	FTKA02565S	TW08S	-	$\varnothing 16 \sim \varnothing 100$

HSK63A AM2000HS

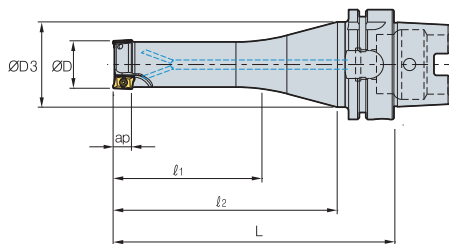

• AR : 7°~10°
• RR : -20°~-7°

(мм)

Обозначение		$\varnothing D$	$\varnothing D_3$	ℓ_1	ℓ_2	L	ap
HSK63A AM2016HS-2	2	16	43	45	83	116	11
AM2016HS-2L	2	16	43	35	118	151	11
AM2020HS-2	2	20	43	60	98	131	11
AM2020HS-2L	2	20	43	50	118	151	11
AM2025HS-3	3	25	43	75	113	146	11
AM2025HS-3L	3	25	43	65	113	146	11
AM2032HS-4	4	32	43	80	113	146	11
AM2032HS-4L	4	32	43	70	133	166	11
AM2040HS-5	5	40	47	60	98	131	11
AM2040HS-5L	5	40	47	50	118	151	11
AM2050HS-6	6	50	47	60	98	131	11
AM2050HS-6L	6	50	47	50	118	151	11

Применяемые СМП

	APMT-MA		APMT-ML				APMT-MM			APMT-MF							
Обозначение	Тв. сплав с покрытием								Кермет			Тв. сплав				Стр.	
	NCM325	NCM335	NC5330	PC3500	PC5300	PC5400	PC3545	PC9530	PC6510	PD2000	CN2000	CN20	CN60	H01	G10		ST30A
APMT 11T3PDR-MA																	
11T3PDR-ML																	
11T3PDR-MM	•		•	•	•	•	•	•	•								
11T3PDR-MF	•		•	•	•	•	•	•	•								
11T308PDR-MM	•		•	•	•	•	•	•	•								
11T312PDR-MM	•		•	•	•	•	•	•	•								
11T316R-MM	•		•	•	•	•	•	•	•								
11T318R-MM	•		•	•	•	•	•	•	•								
11T324R-MM			•	•	•		•										

Комплектующие

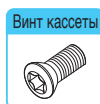

Винт кассеты



Ключ

FTKA02565S

TW08S

HSK63A AM3000HS / 4000HS

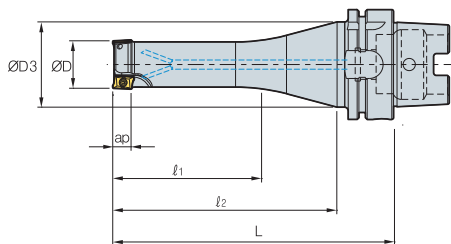

AA
90°
• AR : 7°~10°
• RR : -20°~7°

(мм)

Обозначение		$\varnothing D$	$\varnothing D3$	l_1	l_2	L	ap
HSK63A AM3025HS-2	2	25	43	65	113	146	16
AM3025HS-2L	2	25	43	55	123	156	16
AM3032HS-3	3	32	43	70	113	146	16
AM3032HS-3L	3	32	43	60	123	156	16
AM3040HS-4	4	40	47	50	98	131	16
AM3040HS-4L	4	40	47	40	108	141	16
AM3050HS-5	5	50	47	50	98	131	16
AM3050HS-5L	5	50	47	40	108	141	16
HSK63A AM4020HS-1	1	20	43	50	98	131	17
AM4025HS-2	2	25	43	65	113	146	17
AM4032HS-3	3	32	43	70	113	146	17
AM4032HS-3L	3	32	43	60	123	156	17
AM4040HS-4	4	40	47	50	98	131	17
AM4040HS-4L	4	40	47	40	108	141	17
AM4050HS-5	5	50	47	50	98	131	17
AM4050HS-5L	5	50	47	40	108	141	17

Применяемые СМП

APMT-MA APMТ-ML APMТ-MM APMТ-MF



Тип	Обозначение	Тв. сплав с покрытием								Кермет			Тв. сплав				Стр.	
		NCM825	NCM335	NC5330	PC3500	PC5300	PC5400	PC3545	PC9530	PC6510	PD2000	CN2000	CN20	CN30	H01	G10		ST30A
3000 Тип	APMT 1604PDR-MA																	
	1604PDR-ML																	
	1604PDR-MM	•		•	•	•	•	•	•	•								
	1604PDR-MF	•		•	•	•	•	•	•	•								
	160410PDR-MM	•		•	•	•	•	•	•	•								
	160416PDR-MM	•		•	•	•	•	•	•	•								
	160424R-MM			•	•	•	•	•	•	•								
	160430R-MM			•	•	•	•	•	•	•								
4000 Тип	APMT 1806PDR-MA																	
	1806PDR-ML																	
	1806PDR-MM	•		•	•	•	•	•	•	•								
	1806PDR-MF	•		•	•	•	•	•	•	•								
	1806PDR-ML			•	•	•	•	•	•	•								
	180612PDR-MM	•		•	•	•	•	•	•	•								
	180616PDR-MM			•	•	•	•	•	•	•								
	180620PDR-MM			•	•	•	•	•	•	•								
	180624PDR-MM			•	•	•	•	•	•	•								
	180630R-MM			•	•	•	•	•	•	•								
180632R-MM			•	•	•	•	•	•	•									

Комплектующие

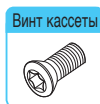

3000 Тип	FTKA0408 FTKA0410	TW15S	$\varnothing 25$ $\varnothing 32 \sim \varnothing 100$
4000 Тип	FTKA0408 FTKA0410	TW15S	$\varnothing 20 \sim \varnothing 25$ $\varnothing 32 \sim \varnothing 200$

ВТ30/40 AM1000/1500

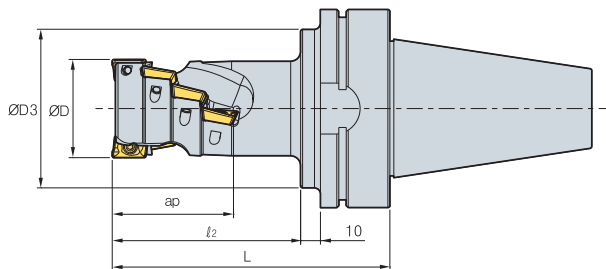

AA
90°

• AR : -12.5°~13°
• RR : -17°~6°

(мм)

Обозначение		$\varnothing D$	$\varnothing D_3$	l_2	L	Количество зубьев	a_p
BT30 AM1016015-2	6	16	80	30	62	2	15.5
AM1020020-3	12	20	80	32	64	3	20.5
AM1025025-4	20	25	80	39	71	4	25.5
BT40 AM1016015-2	6	16	80	30	67	2	15.5
AM1020020-3	12	20	80	32	69	3	20.5
AM1025025-4	20	25	80	39	76	4	25.5
BT30 AM15020026-1	3	20	80	42	74	1	26.5
AM15025035-2	8	25	80	50	62	2	35
AM15032044-2	10	32	80	60	92	2	44
BT40 AM15020026-1	3	20	80	42	79	1	26.5
AM15025035-2	8	25	80	50	87	2	35
AM15032044-2	10	32	80	60	97	2	44

Применяемые СМП

APMT-MA

APMT-ML

APMT-MM



Тип	Обозначение	Тв. сплав с покрытием									Кермет			Тв. сплав				Стр.	
		NCM325	NCM335	NC5330	PC3500	PC5300	PC5400	PC3545	PC3530	PC6510	PD2000	CN2000	CN20	CN30	H01	G10	ST30A		ST20
1000 Тип	APMT 0602PDR-MA																		
	060202PDSR-MM			●	●	●	●	●											
	0602PDR-MM			●	●	●	●	●	●										
	060208PDSR-MM			●	●	●	●	●											
	060212R-MM			●	●	●													
1500 Тип	APMT 0903PDR-MA																		
	0903PDR-ML						●												
	0903PDSR-MM			●	●	●	●	●											
	090308PDSR-MM			●	●	●	●	●											
	090312R-MM					●	●	●											
	090316R-MM					●	●	●											
	090320R-MM					●	●												

Рекомендации по выбору СМП

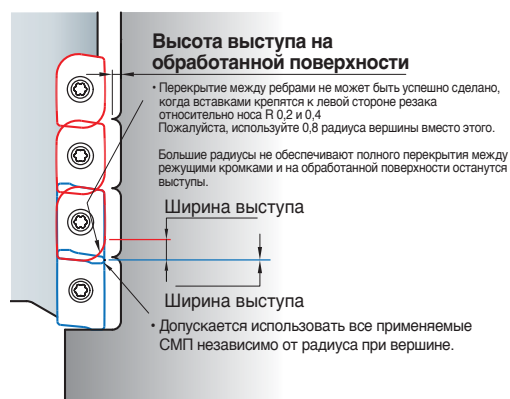

Комплектующие

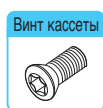

Винт кассеты



Ключ



Ключ

Диаметр фрезы, мм



1000 Тип	FTKA01842	-	TW06S-A	Ø10~Ø63
1500 Тип	FTKA02565S	TW08S	-	Ø16~Ø100

ВТ30/40 АМ2000

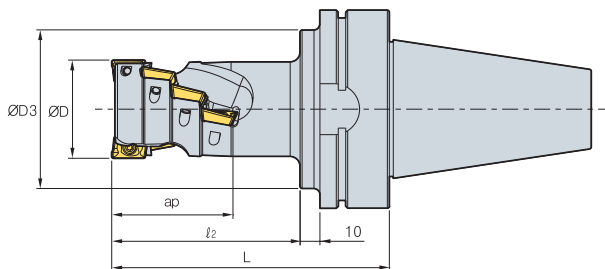

AA
90°
• AR : -9°
• RR : -13°~8°

(мм)

Обозначение		$\varnothing D$	$\varnothing D_3$	l_2	L	Количество зубьев	a_p	
ВТ30	AM2020029-1	3	20	80	45	77	1	29.4
	AM2025038-2	8	25	80	55	87	2	38.9
	AM2032048-2	10	32	80	65	97	2	48.5
	AM2040058-2	14	40	80	75	107	2	58
	AM2050039-4	16	50	80	58	90	4	39
	AM2063039-4	16	63	80	58	90	4	39
	AM2080039-5	20	80	80	63	95	5	39
ВТ40	AM2100039-6	24	100	80	63	95	6	39
	AM2020029-1	3	20	80	45	82	1	29.4
	AM2025038-2	8	25	80	55	92	2	38.9
	AM2032048-2	10	32	80	65	102	2	48.5
	AM2040058-2	14	40	80	75	112	2	58
	AM2050039-4	16	50	80	58	95	4	39
	AM2063039-4	16	63	80	58	95	4	39
AM2080039-5	20	80	80	63	100	5	39	
AM2100039-6	24	100	80	63	100	6	39	

Применяемые СМП

APMT-MA

APMT-ML

APMT-MM

APMT-MF



Обозначение	Тв. сплав с покрытием							Кермет			Тв. сплав				Стр.			
	NCM325	NCM335	NC5330	PC3500	PC5300	PC5400	PC3545	PC9530	PC6510	PD2000	CN2000	CN20	CN30	H01		G10	ST30A	ST20
APMT 11T3PDFR-MA																		E05
11T3PDER-ML																		
11T3PDSR-MM	•		•	•	•	•	•	•										
11T3PDSR-MF	•		•	•	•	•	•	•										
11T308PDSR-MM	•		•	•	•	•	•	•										
11T312PDSR-MM	•		•	•	•	•	•	•										
11T316R-MM	•		•	•	•	•	•	•										
11T318R-MM																		
11T324R-MM			•	•	•		•											

Рекомендации по выбору СМП



Комплектующие

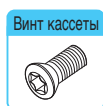

FTKA02565S



TW08S



BT50 AM3000/4000

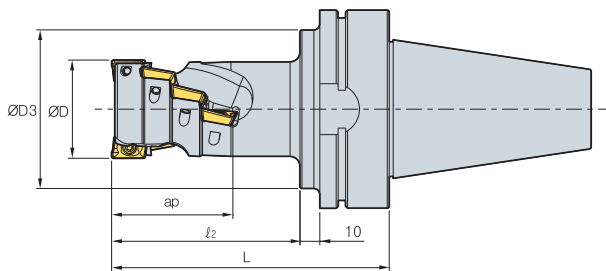

AA
90°
• AR : 13°~15°
• RR : -11°~4°

(мм)

Обозначение		$\varnothing D$	$\varnothing D_3$	l_2	L	Количество зубьев	a_p	
BT50	AM3050043-2	6	50	80	72	120	2	43
	AM3063057-4	16	63	80	86	134	4	57
	AM3080071-4	20	80	80	100	148	4	71
	AM3100071-6	30	100	80	100	148	6	71
BT50	AM4040046-2	6	40	80	75	123	2	46
	AM4050061-2	8	50	80	95	143	2	61
	AM4063061-4	16	63	80	95	143	4	61
	AM4080076-4	20	80	80	105	153	4	76
	AM4100076-6	30	100	80	105	153	6	76

Применяемые СМП

Тип	Обозначение	Тв. сплав с покрытием								Кермет			Тв. сплав				Стр.	
		NCM325	NCM335	NC5330	PC3500	PC5300	PC5400	PC3545	PC9530	PC6510	PD2000	CN2000	CN20	CN30	H01	G10		ST30A
3000 Тип	APMT 1604PDFR-MA																	
	1604PDER-ML																	
	1604PDSR-MM	•		•	•	•	•	•	•									
	1604PDSR-MF	•		•	•	•	•	•	•									
	160410PDSR-MM	•		•	•	•	•	•	•									
	160416PDSR-MM	•		•	•	•	•	•	•									
	160424R-MM			•	•	•	•	•	•									
	160430R-MM			•	•	•	•	•	•									
4000 Тип	APMT 1806PDFR-MA																	
	1806PDER-ML																	
	1806PDSR-MM	•		•	•	•	•	•	•									
	1806PDSR-MF	•		•	•	•	•	•	•									
	180612PDSR-MM	•		•	•	•	•	•	•									
	180616PDSR-MM	•		•	•	•	•	•	•									
	180620PDSR-MM			•	•	•	•	•	•									
	180624PDSR-MM			•	•	•	•	•	•									
180630R-MM			•	•	•	•	•	•										
180632R-MM			•	•	•	•	•	•										

Рекомендации по выбору СМП



Комплектующие

Винт кассеты



Ключ



3000 Тип	FTKA0410	TW15S
4000 Тип	FTKA0410	TW15S

BT50 HAT4000

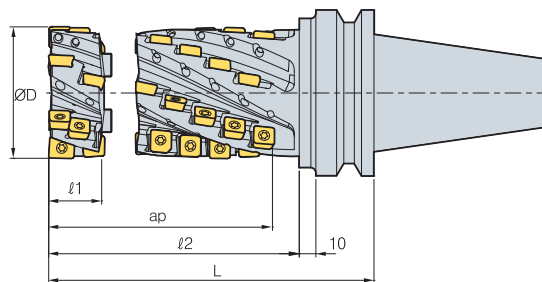

Обозначение				$\varnothing D$	l_1	l_2	L	Количество зубьев	ap	Применяемый съемный торец
		SPMT	ZPMT							
(конструкция в сборе)	HAT4050094-2F	10	1	50	32	119	160	2	94	HAT4050032-2F
	HAT4050104-2F	11	1	50	32	129	170	2	104	
	HAT4050114-2F	12	1	50	32	139	180	2	114	
	HAT4063094-4F	20	2	63	32	119	160	4	94	HAT4063032-4F
	HAT4063104-4F	22	2	63	32	129	170	4	104	
	HAT4063114-4F	24	2	63	32	139	180	4	114	
	HAT4080094-4F	20	2	80	33	119	160	4	94	HAT4080033-4F
HAT4080104-4F	22	2	80	33	129	170	4	104		
HAT4080114-4F	24	2	80	33	139	180	4	114		
(съемный торец)	HAT4050032-2F	3	1	50	32	-	-	2	-	-
	HAT4063032-4F	6	2	63	32	-	-	4	-	-
	HAT4080033-4F	6	2	80	33	-	-	4	-	-

Применяемые СМП

SPMT-MM

ZPMT-MM



Обозначение	Тв. сплав с покрытием									Кермет			Тв. сплав				Стр.	
	NCM325	NCM335	NC5330	PC3500	PC5300	PC3545	PC9530	PC6510	PC215K	PD2000	CN2000	CN20	CN30	H01	G10	ST30A		ST20
SPMT 120508-MMN																		E21
ZPMT 1505PPSR-MMN																		E24

Обозначение деталей в спецификации

Фреза	Обозначение	Съемный торец	Винт
HAT4050094-2F	HAT4050062-2F		
HAT4050104-2F	HAT4050072-2F	HAT4050032-2F	HSB1255
HAT4050114-2F	HAT4050082-2F		
HAT4063094-4F	HAT4063062-4F		
HAT4063104-4F	HAT4063072-4F	HAT4063032-4F	HSB1670
HAT4063114-4F	HAT4063082-4F		
HAT4080094-4F	HAT4080061-4F		
HAT4080104-4F	HAT4080071-4F	HAT4080033-4F	HSB1682
HAT4080114-4F	HAT4080081-4F		

Комплектующие

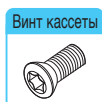

ETNA0511

TW20

HSK63A AM1000/1500

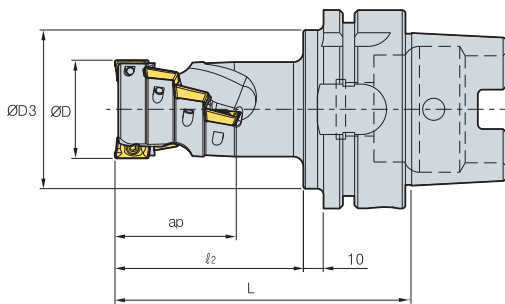

• AR : -12.5°~13°

• RR : -17°~6°

Обозначение		$\varnothing D$	$\varnothing D_3$	l_2	L	Количество зубьев	a_p
HSK63A AM1016015-2	6	16	80	30	66	2	15.5
AM1020020-3	12	20	80	32	68	3	20.5
AM1025025-4	20	25	80	39	75	4	25.5
HSK63A AM15020026-1	3	20	80	42	78	1	26.5
AM15025035-2	8	25	80	50	86	2	35
AM15032044-2	10	32	80	60	96	2	44

Применяемые СМП

Тип	Обозначение	Тв. сплав с покрытием								Кермет			Тв. сплав				Стр.	
		NCM325	NCM335	NC5330	PC3500	PC5300	PC5400	PC3545	PC9630	PC6510	PD2000	CN2000	CN20	CN30	H01	G10		ST30A
1000 Тип	APMT 0602PDFR-MA																	
	060202PDSR-MM			•	•	•	•	•										
	0602PDSR-MM			•	•	•	•	•	•									
	060208PDSR-MM			•	•	•	•	•										
	060212R-MM			•	•	•												
	060216R-MM				•													
1500 Тип	APMT 0903PDFR-MA																	
	0903PDER-ML							•										
	0903PDSR-MM			•	•	•	•	•										
	090308PDSR-MM			•	•	•	•	•										
	090312R-MM				•	•	•											
	090316R-MM				•	•	•											
	090320R-MM				•	•												

Рекомендации по выбору СМП

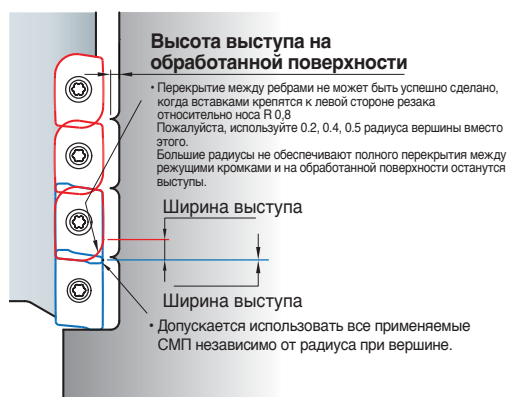

Комплектующие



Винт кассеты



Ключ



Ключ

1000 Тип	FTKA01842	-	TW06S-A
1500 Тип	FTKA02565S	TW08S	-

HSK63A AM2000

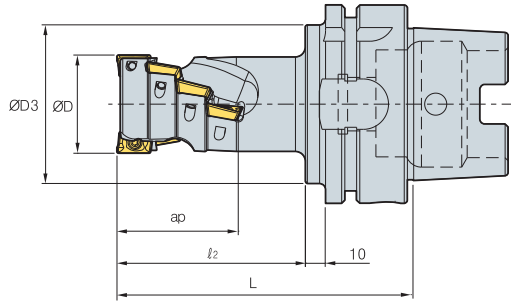

• AR : -12.5°~13°
• RR : -17°~6°

(мм)

Обозначение		$\varnothing D$	$\varnothing D_3$	ϱ_2	L	Количество зубьев	a_p
HSK63A AM2020029-1	3	20	80	45	81	1	29.4
AM2025038-2	8	25	80	55	91	2	38.9
AM2032048-2	10	32	80	65	101	2	48.5
AM2040058-2	14	40	80	75	111	2	58
AM2050039-4	16	50	80	58	94	4	39
AM2063039-4	16	63	80	58	94	4	39
AM2080039-5	20	80	80	63	99	5	39
AM2100039-6	24	100	80	63	99	6	39

Применяемые СМП

APMT-MA

APMT-ML

APMT-MM

APMT-MF



Обозначение	Тв. сплав с покрытием								Кермет			Тв. сплав				Стр.	
	NCM325	NCM335	NC5330	PC3500	PC5300	PC5400	PC3545	PC9530	PC6510	PD2000	CN2000	CN20	CN30	H01	G10		ST30A
APMT 11T3PDFR-MA																	
11T3PDER-ML																	
11T3PDSR-MM	•		•	•	•	•	•	•									
11T3PDSR-MF	•		•	•	•	•	•	•									
11T308PDSR-MM	•		•	•	•	•	•	•									
11T312PDSR-MM	•		•	•	•	•	•	•									
11T316R-MM	•		•	•	•	•	•	•									
11T318R-MM																	
11T324R-MM			•	•	•		•										

E05

Рекомендации по выбору СМП

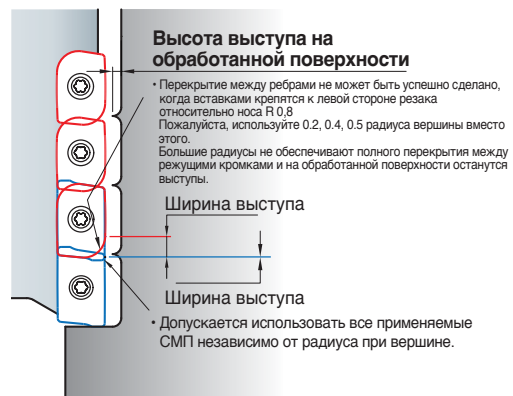

Комплектующие

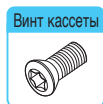

FTKA02565S



TW08S



HSK100A AM3000

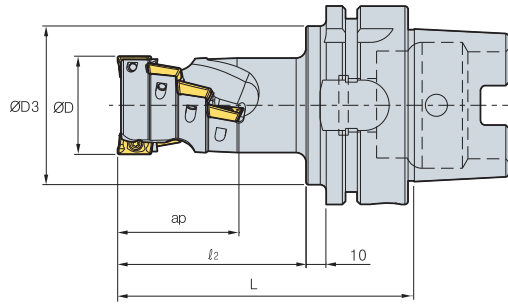

• AR : $-13^{\circ} \sim 15^{\circ}$
• RR : $-11^{\circ} \sim 4^{\circ}$

Обозначение			$\varnothing D$	$\varnothing D_3$	l_2	L	Количество зубьев	ap
HSK100A	AM3050043-2	6	50	80	72	111	2	43
	AM3063057-4	16	63	80	86	125	4	57
	AM3080071-4	20	80	80	100	139	4	71
	AM3100071-6	30	100	80	100	139	6	71

Применяемые СМП

Обозначение	APMT-MA		APMT-ML				APMT-MM				APMT-MF				Стр.			
	NCM325	NCM335	NC5330	PC3500	PC5300	PC5400	PC3545	PC9530	PC6510	PD2000	CN2000	CN20	CN30	H01		G10	ST30A	ST20
APMT 1604PDFR-MA																		E05
1604PDER-ML						•												
1604PDSR-MM	•		•	•	•	•	•	•	•									
1604PDSR-MF	•		•	•	•	•	•	•	•									
160410PDSR-MM	•		•	•	•	•	•	•	•									
160416PDSR-MM	•		•	•	•	•	•	•	•									
160424R-MM			•	•	•	•	•	•	•									
160430R-MM			•	•	•	•	•	•	•									
160432R-MM	•		•	•	•	•	•	•	•									

Рекомендации по выбору СМП



Комплектующие

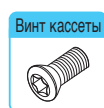

FTKA0410



TW15S

HSK100A AM4000

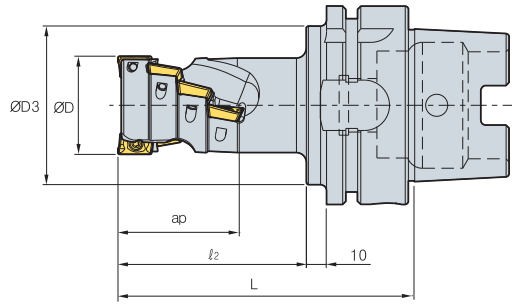

• AR : -13°~15°
• RR : -11°~4°

(мм)

Обозначение		$\varnothing D$	$\varnothing D_3$	l_2	L	Количество зубьев	a_p
HSK100A AM4040046-2	6	40	80	75	114	2	46
AM4050061-2	8	50	80	95	134	2	61
AM4063061-4	16	63	80	90	129	4	61
AM4080076-4	20	80	80	105	144	4	76
AM4100076-6	30	100	80	105	144	6	76

Применяемые СМП

Обозначение	APMT-MA		APMT-ML				APMT-MM			APMT-MF				Стр.			
			Тв. сплав с покрытием				Кермет			Тв. сплав							
	NCM325	NCM335	NC5330	PC3500	PC5300	PC5400	PC3545	PC9530	PC6510	PD2000	CN2000	CN20	CN60	H01	G10	ST30A	ST20
APMT 1806PDR-MA																	
1806PDR-ML																	
1806PDR-MM	•		•	•	•	•	•	•	•								
1806PDR-MF			•	•	•	•	•	•									
180612PDR-MM	•		•	•	•	•	•	•									
180616PDR-MM			•			•											
180620PDR-MM			•														
180624PDR-MM			•	•		•											
180630R-MM				•													
180632R-MM			•	•		•	•										

Рекомендации по выбору СМП

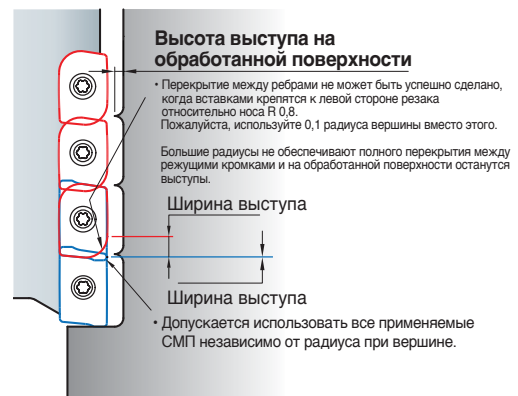

Комплектующие

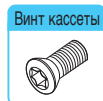

FTKA0410



TW15S



BT30/BT40/BT50

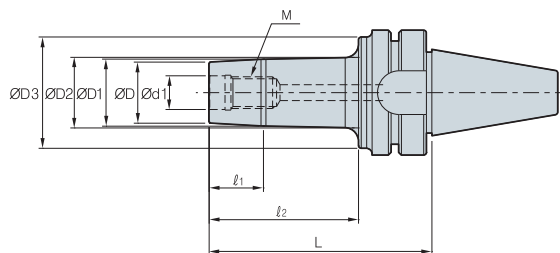

(mm)

Обозначение	ØD	ØD ₁	ØD ₂	ØD ₃	Ød ₁	l ₁	l ₂	L	M	
BT30	MAT-M06-053	11	11.7	13	30	6.5	5	21	53	06*1.0
	MAT-M08-057	14.5	15.7	17.5	35	8.5	7	25	57	08*1.25
	MAT-M10-062	18	19.7	24	38	10.5	7	30	62	10*1.5
	MAT-M12-067	23	24.7	27.5	41	12.5	10	35	67	12*1.75
BT40	MAT-M16-067	29	31.7	33.5	41	17	10	35	67	16*2.0
	MAT-M06-062	11	11.7	14	40	6.5	5	25	62	08*1.0
	MAT-M06-077	11	11.7	14	40	6.5	5	40	77	06*1.0
	MAT-M06-092	11	11.7	14	40	6.5	5	55	92	06*1.0
	MAT-M08-067	14.5	15.7	19	44	8.5	7	30	67	08*1.25
	MAT-M08-082	14.5	15.7	19	44	8.5	7	45	82	08*1.25
	MAT-M08-097	14.5	15.7	19	44	8.5	7	60	97	08*1.25
	MAT-M10-072	18	19.7	23	50	10.5	10	35	72	10*1.5
	MAT-M10-087	18	19.7	23	50	10.5	10	50	87	10*1.5
	MAT-M10-102	18	19.7	23	50	10.5	10	65	102	10*1.5
	MAT-M12-077	23	24.7	30	55	12.5	10	40	77	12*1.75
	MAT-M12-092	23	24.7	30	55	12.5	13	55	92	12*1.75
	MAT-M12-107	23	24.7	30	55	12.5	13	70	107	12*1.75
	MAT-M16-077	29	31.7	37	55	17	13	40	77	16*2.0
MAT-M16-092	29	31.7	37	55	17	13	55	92	16*2.0	
MAT-M16-107	29	31.7	37	55	17	13	70	107	16*2.0	
BT50	MAT-M06-083	11	11.7	15	40	6.5	5	35	83	06*1.0
	MAT-M06-098	11	11.7	15	40	6.5	5	50	98	06*1.0
	MAT-M06-113	11	11.7	15	40	6.5	5	65	113	06*1.0
	MAT-M08-088	14.5	15.7	20	45	8.5	7	40	88	08*1.25
	MAT-M08-103	14.5	15.7	20	45	8.5	7	55	103	08*1.25
	MAT-M08-118	14.5	15.7	20	45	8.5	7	70	118	08*1.25
	MAT-M10-093	18	19.7	25	55	10.5	10	45	93	10*1.5
	MAT-M10-113	18	19.7	25	55	10.5	10	65	113	10*1.5
	MAT-M10-128	18	19.7	25	55	10.5	10	80	128	10*1.5
	MAT-M12-103	23	24.7	33	65	12.5	10	55	103	12*1.75
	MAT-M12-118	23	24.7	33	65	12.5	13	70	118	12*1.75
	MAT-M12-133	23	24.7	33	65	12.5	13	85	133	12*1.75
	MAT-M16-103	29	31.7	41	85	17	13	55	103	16*2.0
	MAT-M16-118	29	31.7	41	85	17	13	70	118	16*2.0
MAT-M16-133	29	31.7	41	85	17	13	85	133	16*2.0	



HSK63A/HSK100A

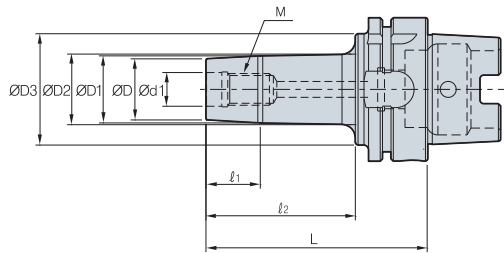

Обозначение		$\varnothing D$	$\varnothing D_1$	$\varnothing D_2$	$\varnothing D_3$	$\varnothing d_1$	l_1	l_2	L	M
HSK63A	MAT-M06-061	11	11.7	27	40	6.5	5	25	61	06*1.0
	MAT-M06-076	11	11.7	27	40	6.5	5	40	76	06*1.0
	MAT-M06-091	11	11.7	27	40	6.5	5	55	91	06*1.0
	MAT-M08-066	14.5	15.7	30.5	44	8.5	7	30	66	08*1.25
	MAT-M08-081	14.5	15.7	30.5	44	8.5	7	45	81	08*1.25
	MAT-M08-096	14.5	15.7	30.5	44	8.5	7	60	96	08*1.25
	MAT-M10-071	18	19.7	34	50	10.5	10	35	71	10*1.5
	MAT-M10-086	18	19.7	34	50	10.5	10	50	86	10*1.5
	MAT-M10-101	18	19.7	34	50	10.5	10	65	101	10*1.5
	MAT-M12-076	23	24.7	36.5	55	12.5	10	40	76	12*1.75
	MAT-M12-091	23	24.7	36.5	55	12.5	13	55	91	12*1.75
	MAT-M12-106	23	24.7	36.5	55	12.5	13	70	106	12*1.75
	HSK100A	MAT-M16-076	29	31.7	38.5	55	17	13	40	76
MAT-M16-091		29	31.7	38.5	55	17	13	55	91	16*2.0
MAT-M16-106		29	31.7	38.5	55	17	13	70	106	16*2.0
MAT-M06-074		11	11.7	15	40	6.5	5	35	74	06*1.0
MAT-M06-089		11	11.7	15	40	6.5	5	50	89	06*1.0
MAT-M06-104		11	11.7	15	40	6.5	5	65	104	06*1.0
MAT-M08-079		14.5	15.7	20	45	8.5	7	40	79	08*1.25
MAT-M08-094		14.5	15.7	20	45	8.5	7	55	94	08*1.25
MAT-M08-109		14.5	15.7	20	45	8.5	7	70	109	08*1.25
MAT-M10-084		18	19.7	25	55	10.5	10	45	84	10*1.5
MAT-M10-104		18	19.7	25	55	10.5	10	65	104	10*1.5
MAT-M10-119		18	19.7	25	55	10.5	10	80	119	10*1.5
MAT-M12-094		23	24.7	33	65	12.5	10	55	94	12*1.75
MAT-M12-109	23	24.7	33	65	12.5	13	70	109	12*1.75	
MAT-M12-124	23	24.7	33	65	12.5	13	85	124	12*1.75	
MAT-M16-094	29	31.7	41	85	17	13	55	94	16*2.0	
MAT-M16-109	29	31.7	41	85	17	13	70	109	16*2.0	
MAT-M16-124	29	31.7	41	85	17	13	85	124	16*2.0	



Высокая жесткость алюминиевого корпуса

Future Mill

- Высокая эффективность обработки при высокоскоростном резании благодаря легкому алюминиевому корпусу, который составляет 50% веса традиционного стального корпуса фрезы.
- Возможность применения на станке с малой мощностью.
- Широкий диапазон применения. Обработка заготовок из алюминия, стали и чугуна.
- Высокая жесткость алюминиевого корпуса.
- Увеличение эксплуатационной надежности корпуса за счет применения сменной кассеты для крепления СМП.
- Возможность применения СМП различной геометрии.
- Низкие силы резания за счет больших передних осевых и радиальных углов обеспечивающие высокую точность и качество обработки.

Схема сборки фрезы

- ▶ Значительный размер стружечной канавки предотвращает пакетирование стружки.
- ▶ Высокая жесткость корпуса.
- ▶ Наличие специального покрытия на поверхности стружечной канавки предотвращает налипание и уменьшает трение стружки.

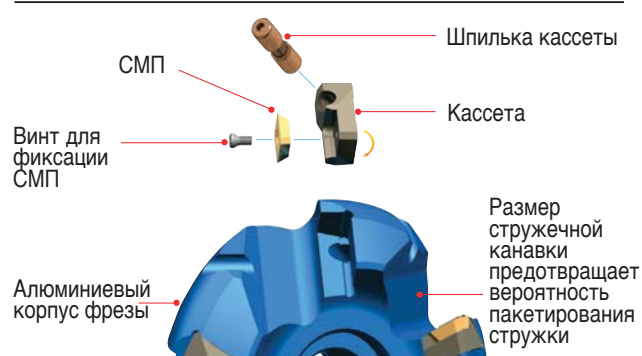

Кассета

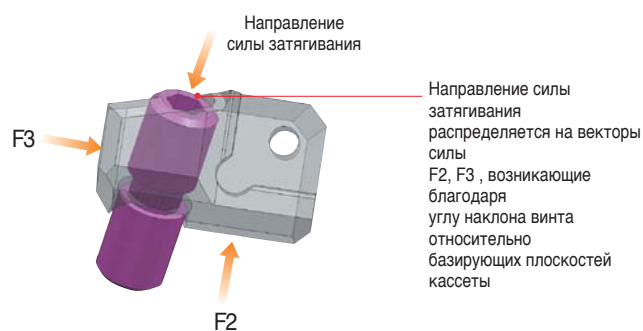
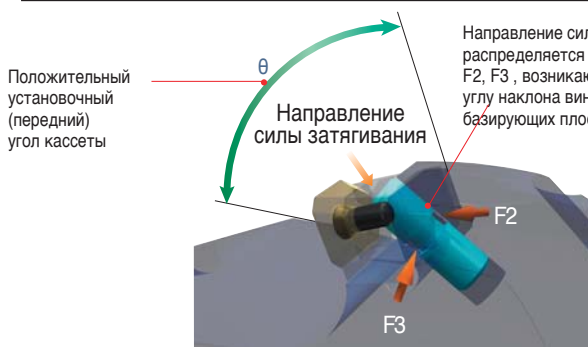

Система сквозного охлаждения

- ▶ Специально разработанная система сквозного охлаждения обеспечивает стабильную подачу СОЖ через центральное отверстие корпуса к СМП. Это улучшает эффективность охлаждения и удаления стружки из зоны резания.
- ▶ Распределитель охлаждения применим при диаметре фрезы до D160, запорная – до D 200 и выше.
- ▶ Оба устройства для охлаждения приобретаются отдельно. При системе сквозного охлаждения подача СОЖ осуществляется через шпиндель.

• D: 63 ~ 160

• D 200 мм и выше

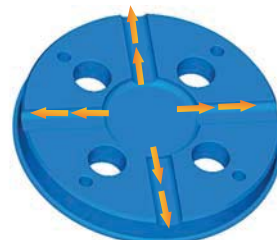
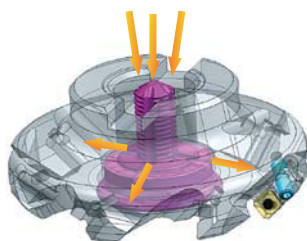

Рекомендуемые режимы резания

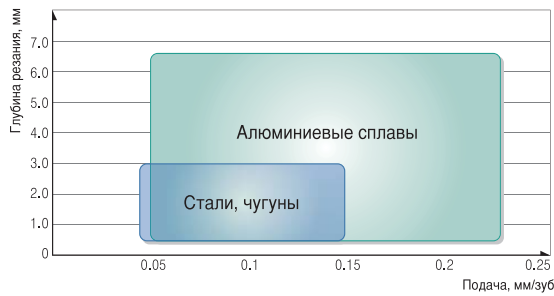

Рекомендации

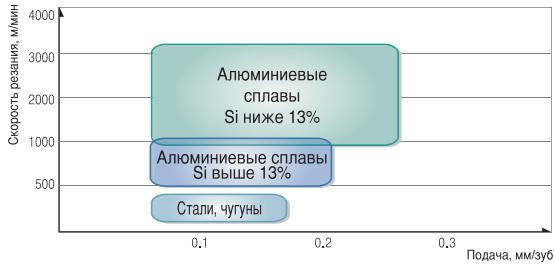

Максимально допустимая частота вращения, об/мин

Диаметр фрезы	Частота вращения, об/мин
Ø63	20,000
Ø80	16,000
Ø100	13,000
Ø125	10,000
Ø160	8,000
Ø200	6,500
Ø250	5,000
Ø315	4,000

Future Mill(FMA)

Общие характеристики

- ▶ Применяется для универсальной обработки высоко-средне-низкоуглеродистой стали, чугуна и алюминия.
- ▶ Обеспечивает высокое качество обработанной поверхности за счет наличия зачистных кромок СМП.
- ▶ В зависимости от вида и условий обработки существует возможность выбора необходимого угла в плане.

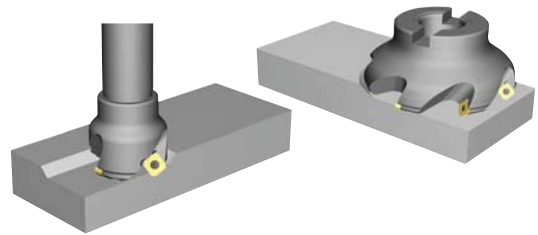

Рекомендации по выбору стружколомов

Вид обработки	Стружколом	Геометрия режущей кромки	Общие характеристики of chip breaker
Чистовая обработка	Нет обозначения стружколома		Изготовление СМП на основе кермета.
	MF		Получение высокого качества поверхности при обработке низко и среднеуглеродистых сталей.
Универсальное применение	MM		Универсальная обработка различных сталей и сплавов.
Черновая обработка	MR		Высокая стойкость режущей кромки при ударных нагрузках.
Обработка алюминия	MA		Уменьшение сил резания и препятствие наростообразованию.

Рекомендуемые режимы резания

ISO	Стружколом Марка сплава	MF		MM		MR		MA	
		V(м/мин)	Sz(мм/зуб)	V(м/мин)	Sz(мм/зуб)	V(м/мин)	Sz(мм/зуб)	V(м/мин)	Sz(мм/зуб)
P	NC5330	200 ~ 300	0.05 ~ 0.20	150 ~ 300	0.10 ~ 0.30	150 ~ 250	0.10 ~ 0.30	-	-
	NCM325	200 ~ 300	0.05 ~ 0.20	150 ~ 300	0.10 ~ 0.30	150 ~ 250	0.10 ~ 0.30	-	-
	PC3500	200 ~ 300	0.05 ~ 0.20	150 ~ 300	0.10 ~ 0.30	100 ~ 250	0.10 ~ 0.30	-	-
M	PC9530	100 ~ 180	0.05 ~ 0.15	120 ~ 180	0.10 ~ 0.30	-	-	-	-
	NCM335	120 ~ 200	0.05 ~ 0.15	120 ~ 200	0.10 ~ 0.30	-	-	-	-
K	PC5300	150 ~ 250	0.05 ~ 0.20	150 ~ 250	0.10 ~ 0.30	-	-	-	-
Алюминий	H01	-	-	-	-	-	-	350 ~ 1,000	0.10 ~ 0.35



Future Mill(FMP)

Общие характеристики

- ▶ Высокая стойкость СМП при высокой подаче и глубине резания.
- ▶ Широкий выбор марок сплава для обработки различных материалов.
- ▶ Особая геометрия передней поверхности обеспечивает стабильный отвод стружки из зоны резания и способствует снижению сил резания.
- ▶ Упрочняющая фаска главной режущей кромки препятствует выкрашиванию и способствует повышению стойкости.

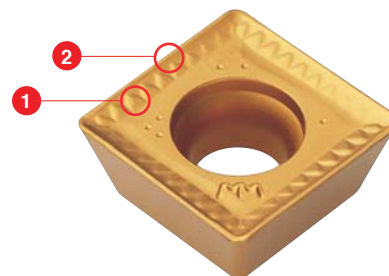

Типовые схемы применения фрез

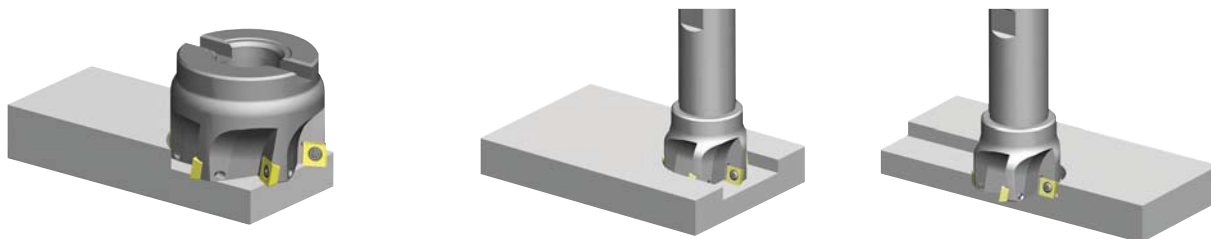

Характеристики и применение СМП

- ▶ Особая геометрия передней поверхности СМП и главной режущей кромки способствует снижению сил резания и уменьшению вибраций в процессе работы.
- ▶ Упрочнение режущих кромок позволяет производить обработку при больших глубинах резания с обеспечением высокой стойкости СМП.

Стружколом	Геометрия режущей кромки	Рекомендации выбора стружколома и марки сплава (●:1-й)									
		Низкоуглеродистые стали		Высокоуглеродистые и легированные стали		Нержавеющая сталь		Чугуны		Алюминиевые сплавы	
		Стружколом	Марка сплава	Стружколом	Марка сплава	Стружколом	Марка сплава	Стружколом	Марка сплава	Стружколом	Марка сплава
Универсальное применение	MF	●	○ NCM325 ○ NC5330 ● NCM335		● NCM325 ○ NC5330 ○ NCM335	●	○ NCM325 ○ NC5330 ● NCM335	●	● PC6510 ○ PC215K	-	-
Черновая обработка	MM		○ NCM325 ○ NC5330 ● NCM335		● NCM325 ○ NC5330 ○ NCM335		○ NCM325 ○ NC5330 ● NCM335		● PC6510 ○ PC215K	-	-
Чистовая обработка алюминия	MA	-	-	-	-	-	-	-	-	●	● H01 ○ G10

Рекомендуемые режимы резания

Обрабатываемые материалы	Диаметр фрезы, мм	Скорость резания, м/мин							
		Тв. сплав с покрытием CVD		Тв. сплав с покрытием PVD					Твердый сплав H01
		NCM325	NCM335	PC3535	PC3545	PC6510	PC8520	PC9530	
Углеродистые стали	~0.3	100~250	100~220	100~250	100~220	-	100~250	100~250	-
Легированные стали									
Высоколегированные стали	~0.25	100~220	100~200	100~220	100~200	-	100~220	100~220	-
Высоколегированные стали									
Легированная сталь высокой прочности	~0.2	100~220	100~180	100~200	100~180	-	100~200	100~200	-
Нержавеющие стали	~0.2	-	-	-	80~200	-	80~200	80~200	-
Чугуны	~0.25	-	-	-	-	100~200	-	-	-
Цветные металлы	~0.4	-	-	-	-	-	-	-	400~1,000



Future Mill(FMR)

Общие характеристики фрез

- ▶ Широкий диапазон применения для обработки различных марок легированных и закаленных сталей.
- ▶ Ступенчатая геометрия задней поверхности обеспечивает точное позиционирование и жесткое крепление СМП.
- ▶ Возможность проворота СМП 4\$8 раза.
- ▶ Асимметричное расположение СМП по окружности уменьшает вероятность появления вибраций.
- ▶ Эргономичность при замене режущей кромки СМП.
- ▶ Высокая точность позиционирования за счет восьмигранной опорной базы СМП.



Виды обработки

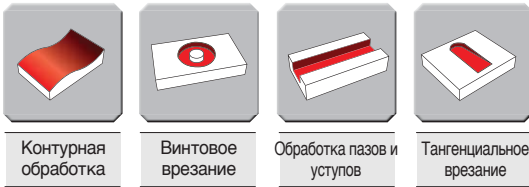

Контурная обработка Винтовое врезание Обработка пазов и уступов Тангенциальное врезание

Геометрические особенности режущих кромок СМП

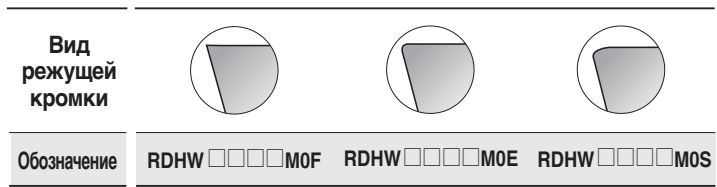

Рекомендации по выбору стружколомов

Стружколом	Геометрия режущей кромки	Рекомендации
Чистовая обработка MF		Низкие силы резания, высокая стойкость СМП, высокое качество обработанной поверхности при фрезеровании труднообрабатываемых материалов
Универсальное применение MM		Универсальная обработка различных сталей и сплавов
Обработка алюминия MA		Низкие силы резания и препятствие наростообразованию

Система крепления СМП

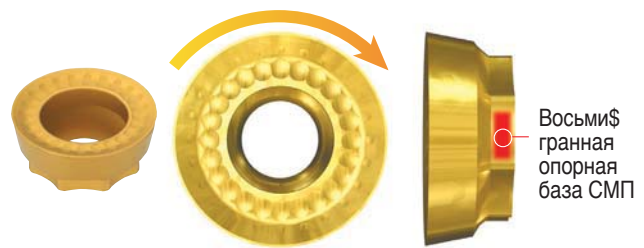
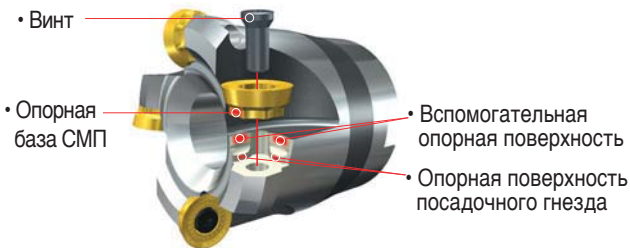

FMR □ 3000 Тип
FMR □ 4000 Тип

FMR □ 5000 Тип
FMR □ 6000 Тип

RDKT10T3M0-□□
RDKT1204M0-□□

RDKT1605M0-MM
RDKT2006M0-MM

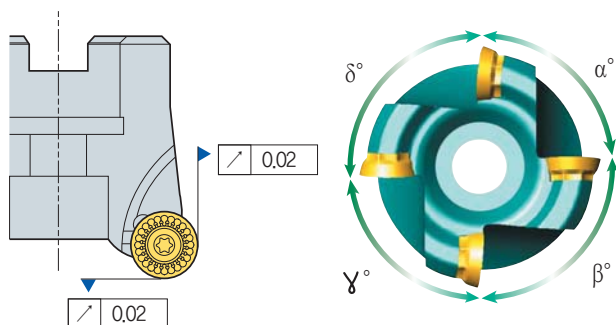

Future Mill(FMR)

Производительность обработки, см³/мин

Обрабатываемые материалы	Марка сплава	Ø8	Ø10	Ø12	Ø15	Ø16	Ø20	Ø21	Ø25	Ø26	Ø32	Ø33	Ø40	Ø50	Ø63	Ø80	Ø100	Ø125	Ø160		
Р	Низкоуглеродистые стали (200НВ) Среднеуглеродистые стали (30НнС) Высокоуглеродистые стали (30-40НнС) Легированные высокоуглеродистые стали (40-50НнС) Легированные высокоуглеродистые стали (выше50НнС)	PC3500 PC3545 PC5300	4.97	9.94	9.94	14.92	31.83	31.83	47.74	47.74	47.74	71.61	38.19	95.49	119.36	143.23	167.11	190.98	133.69	509.29	
			V=250, fz=0.25, ap=0.5, ae=0.5D																		
			3.97	7.95	7.95	11.93	25.46	25.46	38.19	38.19	38.19	57.29	38.19	76.39	95.49	114.59	133.69	152.78	133.69		458.36
			V=200, fz=0.25, ap=0.5, ae=0.5D																		
			2.86	5.72	5.72	8.59	22.91	22.91	34.37	34.37	34.37	51.56	34.37	68.75	85.94	103.13	120.32	137.5	120.32		407.43
			V=180, fz=0.2, ap=0.5, ae=0.5D																		
М	Нержавеющие стали	PC5300	1.24	2.48	2.48	3.72	11.45	11.45	14.32	17.18	14.32	21.48	14.32	28.64	35.8	42.97	50.13	57.29	50.13	249.55	
			V=130, fz=0.15, ap=0.4, ae=0.5D																		
			0.95	1.9	1.9	2.86	7.63	7.63	9.54	11.45	9.54	14.32	9.54	19.09	23.87	28.64	33.42	38.19	33.42		152.78
V=100, fz=0.15, ap=0.4, ae=0.5D																					
К	Чугуны	PC5300	2.06	4.13	4.13	6.2	16.55	16.55	12.41	24.82	12.41	18.62	12.41	24.82	31.03	37.24	43.44	49.65	43.44	331.04	
			V=130, fz=0.2, ap=0.5, ae=0.5D																		
V=180, fz=0.2, ap=1.0, ae=0.5D																					
V=180, fz=0.2, ap=1.5, ae=0.5D																					

Мощность резания, кВт(P_{кв} = 0.75 x P_{нр})

• RDKT10 □ □

Обрабатываемые материалы	Марка сплава	Ø21	Ø25	Ø26	Ø32	Ø40	Ø50	Ø63	Ø80	Ø100	Скорость резания				
											vc	fz	ap	ae	
Р	Низкоуглеродистые стали (200НВ) Среднеуглеродистые стали (30НнС) Высокоуглеродистые стали (30-40НнС) Легированные высокоуглеродистые стали (40-50НнС) Легированные высокоуглеродистые стали (выше50НнС)	PC3500 PC3545 PC5300	2.2	2.2	2.2	3.3	4.4	5.5	6.6	7.7	8.8	250	0.4	1.5	0.5D
			2.1	2.1	2.1	3.1	4.1	5.2	6.2	7.3	8.3	200	0.4	1.5	0.5D
			2.2	2.2	2.2	3.3	4.5	5.6	6.7	7.9	9	180	0.4	1.5	0.5D
			1.1	1.1	1.1	1.6	2.1	2.6	3.2	3.7	4.2	150	0.3	1.0	0.5D
			0.7	0.7	0.7	1.1	1.4	1.7	2.1	2.4	2.8	100	0.3	1.0	0.5D
М	Нержавеющие стали	PC5300	0.6	0.6	0.6	0.8	1.2	1.5	1.7	2	2.3	130	0.2	1.5	0.5D
К	Чугуны	PC5300	0.6	0.6	0.6	0.9	1.2	1.5	1.8	2.1	2.4	180	0.2	1.5	0.5D

• Значения мощности указанные в таблице приняты в л.с. (P_{нр})

• RDKT12 □ □

Обрабатываемые материалы	Марка сплава	Ø32	Ø33	Ø40	Ø50	Ø63	Ø80	Ø100	Ø125	Скорость резания				
										vc	fz	ap	ae	
Р	Низкоуглеродистые стали (200НВ) Среднеуглеродистые стали (30НнС) Высокоуглеродистые стали (30-40НнС) Легированные высокоуглеродистые стали (40-50НнС) Легированные высокоуглеродистые стали (выше50НнС)	PC3500 PC3545 PC5300	1.7	1.7	2.6	3.5	3.5	4.4	5.3	6.1	200	0.4	1.5	0.5D
			2	2	3.1	4.1	2.6	5.2	6.2	7.2	180	0.4	1.5	0.5D
			2.2	2.2	3.3	4.4	2.8	5.6	6.7	7.8	160	0.4	1.5	0.5D
			1	1	1.5	1.6	2.1	2.6	3.1	3.6	140	0.3	1.0	0.5D
			0.7	0.7	1	1.4	0.8	1.7	2.1	2.4	100	0.3	1.0	0.5D
М	Нержавеющие стали	PC5300	0.5	0.5	0.8	1.1	0.7	1.4	1.7	2	130	0.2	1.5	0.5D
К	Чугуны	PC5300	0.6	0.6	0.9	1.2	0.7	1.5	1.8	2.1	180	0.2	1.5	0.5D

• Значения мощности указанные в таблице приняты в л.с. (P_{нр})

Влияние режимов резания на производительность обработки

• Применяемая СМП : RDKT10

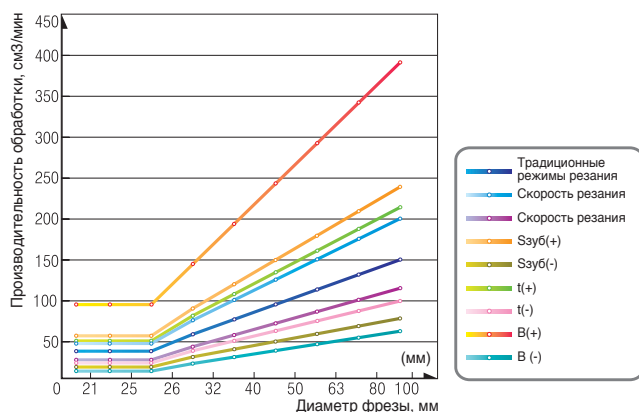

• Рекомендации по изменению режимов резания

Стандартные параметры	ISO			
	V _p =200 S _z =0.4 t=1.5 B=0.5D			
V _p (+)	250			
V _p (-)	150			
S _z (+)	0.6			
S _z (-)	0.2			
t (+)	2			
t (-)	1			
B (+)	D			
B (-)	0.2D			



Рекомендации по выбору режимов резания

- Обработка плоскостей, уступов, боковых поверхностей, наклонных плоскостей, контуров

Обрабатываемые материалы	Твердость	Марка сплава	Скорость резания	FMR1000		FMR1500		FMR2000		FMR2500		FMR3000		FMR4000		FMR5000		FMR6000	
				t, мм	Sz, мм/зуб	t, мм	Sz, мм/зуб	t, мм	Sz, мм/зуб	t, мм	Sz, мм/зуб	t, мм	Sz, мм/зуб	t, мм	Sz, мм/зуб	t, мм	Sz, мм/зуб	t, мм	Sz, мм/зуб
P	200HBs 30HRCs	PC3500	100~250	≤10	≤0.4	≤1.2	≤0.4	≤1.5	≤0.4	≤1.7	≤0.4	≤2.0	≤0.5	≤2.4	≤0.6	≤3.0	≤0.7	≤4.0	≤0.8
				≤0.7	≤0.4	≤1.2	≤0.4	≤1.7	≤0.4	≤2.0	≤0.5	≤2.4	≤0.6	≤3.0	≤0.7	≤4.0	≤0.8		
P	30~40HRC	PC3545	100~200	≤0.7	≤0.2	≤0.9	≤0.2	≤1.2	≤0.2	≤1.5	≤0.2	≤1.7	≤0.3	≤2.0	≤0.4	≤2.7	≤0.5	≤3.7	≤0.6
				≤0.7	≤0.2	≤0.9	≤0.2	≤1.2	≤0.2	≤1.7	≤0.3	≤2.0	≤0.4	≤2.7	≤0.5	≤3.7	≤0.6		
M	270HBs	PC3500	50~200	≤0.7	≤0.2	≤0.9	≤0.2	≤1.2	≤0.2	≤1.5	≤0.2	≤1.7	≤0.3	≤2.0	≤0.4	≤2.7	≤0.5	≤3.7	≤0.6
				≤1.0	≤0.4	≤1.2	≤0.4	≤1.5	≤0.4	≤2.0	≤0.5	≤2.4	≤0.6	≤3.0	≤0.7	≤4.0	≤0.8		

- Обработка закрытых пазов

Обрабатываемые материалы	Твердость	Марка сплава	Скорость резания	FMR1000		FMR1500		FMR2000		FMR2500		FMR3000		FMR4000		FMR5000		FMR6000	
				t, мм	Sz, мм/зуб	t, мм	Sz, мм/зуб	t, мм	Sz, мм/зуб	t, мм	Sz, мм/зуб	t, мм	Sz, мм/зуб	t, мм	Sz, мм/зуб	t, мм	Sz, мм/зуб	t, мм	Sz, мм/зуб
P	200HBs 30HRCs	PC3500	100~250	≤1.0	≤0.3	≤1.2	≤0.3	≤1.5	≤0.3	≤1.7	≤0.3	≤2.0	≤0.4	≤2.4	≤0.5	≤3.0	≤0.6	≤4.0	≤0.7
				≤0.7	≤0.3	≤1.2	≤0.3	≤1.5	≤0.3	≤2.0	≤0.4	≤2.4	≤0.5	≤3.0	≤0.6	≤4.0	≤0.7		
P	30~40HRC	PC3545	100~200	≤0.7	≤0.1	≤0.9	≤0.1	≤1.2	≤0.1	≤1.5	≤0.1	≤1.7	≤0.2	≤2.0	≤0.3	≤2.7	≤0.4	≤3.7	≤0.5
				≤0.7	≤0.1	≤0.9	≤0.1	≤1.2	≤0.1	≤1.7	≤0.2	≤2.0	≤0.3	≤2.7	≤0.4	≤3.7	≤0.5		
M	270HBs	PC3500	50~200	≤0.7	≤0.1	≤0.9	≤0.1	≤1.2	≤0.1	≤1.5	≤0.1	≤1.7	≤0.2	≤2.0	≤0.3	≤2.7	≤0.4	≤3.7	≤0.5
				≤1.0	≤0.3	≤1.2	≤0.3	≤1.5	≤0.3	≤2.0	≤0.4	≤2.4	≤0.5	≤3.0	≤0.6	≤4.0	≤0.7		

- Осевое врезание при ширине фрезерования меньше, чем длина вспомогательной режущей кромки

Обрабатываемые материалы	Твердость	Марка сплава	Скорость резания	FMR1000		FMR1500		FMR2000		FMR2500		FMR3000		FMR4000		FMR5000		FMR6000	
				t, мм	Sz, мм/зуб	t, мм	Sz, мм/зуб	t, мм	Sz, мм/зуб	t, мм	Sz, мм/зуб	t, мм	Sz, мм/зуб	t, мм	Sz, мм/зуб	t, мм	Sz, мм/зуб	t, мм	Sz, мм/зуб
P	200HBs 30HRCs	PC3500	100~250	≤2.5	≤0.2	≤3.0	≤0.2	≤3.5	≤0.2	≤4.0	≤0.2	≤5.0	≤0.3	≤6.0	≤0.4	≤8.0	≤0.5	≤10.0	≤0.6
				≤2.5	≤0.2	≤3.0	≤0.2	≤3.5	≤0.2	≤5.0	≤0.3	≤6.0	≤0.4	≤8.0	≤0.5	≤10.0	≤0.6		
P	30~40HRC	PC3545	100~200	≤2.5	≤0.1	≤3.0	≤0.1	≤3.5	≤0.1	≤4.0	≤0.1	≤5.0	≤0.2	≤6.0	≤0.3	≤8.0	≤0.4	≤10.0	≤0.5
				≤2.5	≤0.1	≤3.0	≤0.1	≤3.5	≤0.1	≤5.0	≤0.2	≤6.0	≤0.3	≤8.0	≤0.4	≤10.0	≤0.5		
M	270HBs	PC3500	50~200	≤2.5	≤0.1	≤3.0	≤0.1	≤3.5	≤0.1	≤4.0	≤0.1	≤5.0	≤0.2	≤6.0	≤0.3	≤8.0	≤0.4	≤10.0	≤0.5
				≤2.5	≤0.1	≤3.0	≤0.1	≤3.5	≤0.1	≤5.0	≤0.2	≤6.0	≤0.3	≤8.0	≤0.4	≤10.0	≤0.5		

- Винтовое врезание

Обрабатываемые материалы	Твердость	Марка сплава	Скорость резания	FMR1000		FMR1500		FMR2000		FMR2500		FMR3000		FMR4000		FMR5000		FMR6000	
				t, мм	Sz, мм/зуб	t, мм	Sz, мм/зуб	t, мм	Sz, мм/зуб	t, мм	Sz, мм/зуб	t, мм	Sz, мм/зуб	t, мм	Sz, мм/зуб	t, мм	Sz, мм/зуб	t, мм	Sz, мм/зуб
P	200HBs 30HRCs	PC3500	100~250	≤1.0	≤0.2	≤1.0	≤0.2	≤1.0	≤0.2	≤1.0	≤0.2	≤2.0	≤0.3	≤2.0	≤0.4	≤4.0	≤0.5	≤4.0	≤0.6
				≤0.7	≤0.2	≤0.7	≤0.2	≤0.7	≤0.2	≤2.0	≤0.3	≤2.0	≤0.4	≤4.0	≤0.5	≤4.0	≤0.6		
P	30~40HRC	PC3545	100~200	≤0.7	≤0.1	≤0.7	≤0.1	≤0.7	≤0.1	≤0.7	≤0.1	≤1.7	≤0.2	≤1.7	≤0.3	≤3.7	≤0.4	≤3.7	≤0.5
				≤0.7	≤0.1	≤0.7	≤0.1	≤0.7	≤0.1	≤1.7	≤0.2	≤1.7	≤0.3	≤3.7	≤0.4	≤3.7	≤0.5		
M	270HBs	PC3500	50~200	≤0.7	≤0.1	≤0.7	≤0.1	≤0.7	≤0.1	≤0.7	≤0.1	≤1.7	≤0.2	≤1.7	≤0.3	≤3.7	≤0.4	≤3.7	≤0.5
				≤0.7	≤0.1	≤0.7	≤0.1	≤0.7	≤0.1	≤1.7	≤0.2	≤1.7	≤0.3	≤3.7	≤0.4	≤3.7	≤0.5		



Амплитудно частотные характеристики (АЧХ) фрезы FMR

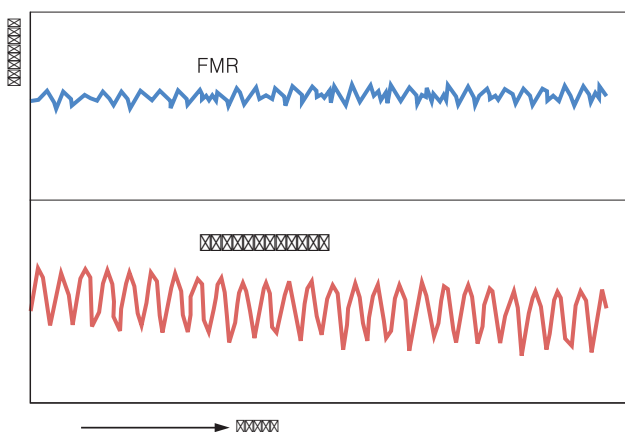

Испытания фрезы на определение АЧХ

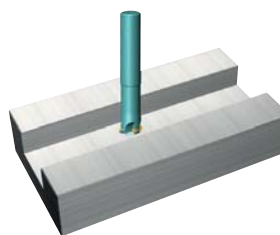

- **Обрабатываемые материалы** STD11
- **Режимы резания** V = 200мм/мин
S3 = 0.40мм/зуб
t = 2.0мм
B = 4.0мм
- **Инструмент** FMRS3032RD-S
RDKT10T3M0-MM (PC3535)

Расчет основных параметров

Скорость резания	Частота вращения
$V_p = \frac{\pi \times D \times n}{1000} \text{ (м/мин)}$	$n = \frac{V_p \times 1000}{\pi \times D} \text{ (мин}^{-1}\text{)}$
Подача S3	Подача, Sмин
$S_3 = \frac{S_{\text{мин}}}{n \times z} \text{ (мм/зуб)}$	$S_{\text{мин}} = S_3 \times n \times z \text{ (мм/мин)}$
Производительность обработки	Мощность резания
$Q = \frac{t \times B \times S_{\text{мин}}}{1000} \text{ (см}^3\text{/мин)}$	$P_c = \frac{Q \times k_c}{60 \times 102 \times \eta} \text{ (kW)}$ $H = \frac{P_c}{0.75} \text{ (HP)}$

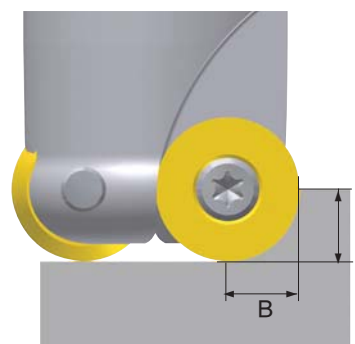

Vp = Скорость резания, м/мин | H = Мощность привода, HP
n = Частота вращения мин⁻¹ | Q = Производительность обработки, см³/мин³
D = Диаметр фрезы, мм | t = Глубина резания, мм
S мин = Подача, мм/мин | B = Ширина фрезерования, мм
S3 = Подача, мм/зуб | Kc = Удельная сила резания, МПа
z = Число зубьев | η = КПД привода, %
Pc = Мощность резания, кВт |

Выбор оптимальной подачи S3 и глубины резания

Обозначение	Стружкойлом	Глубина резания, мм									
		0.2-0.5	0.5-1.0	2.0	3.0	4.0	5.0	6.0	7.0	8.0	
RDHW0501M0	-	0.25	0.15	-	-	-	-	-	-	-	-
RDHW06T1M0	-	0.30	0.20	0.10	-	-	-	-	-	-	-
RDHW0702M0	-	0.35	0.25	0.10	0.07	-	-	-	-	-	-
RDHW0803M0	-	0.40	0.30	0.15	0.01	-	-	-	-	-	-
RDKT10T3M0 -	MF/MM	-	0.40	0.35	0.30	0.20	-	-	-	-	-
RDKT1204M0 -	MF/MM	-	0.50	0.45	0.30	0.25	0.22	-	-	-	-
RDHW1605M0	-	-	0.60	0.50	0.45	0.35	0.30	0.20	0.10	-	-
RDHW2006M0	-	-	-	0.60	0.50	0.40	0.30	0.25	0.15	0.10	-
RDKT1605M0 -	MM	-	0.60	0.50	0.45	0.35	0.30	0.20	0.10	-	-
RDKT2006M0 -	MM	-	-	0.60	0.50	0.40	0.30	0.25	0.15	0.10	-



Технические рекомендации для тангенциального врезания

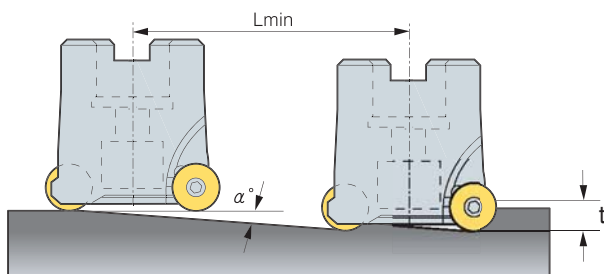

$$L_{min} = \frac{ap}{\tan \alpha^\circ} \text{ (мм)}$$

* L_{min} : Минимальная длина врезания

α° : Максимальный угол врезания

t : Глубина резания

Обозначение фрезы	Диаметр фрезы, мм	Угол врезания α° (Max)	Рекомендуемая длина врезания									
			ap=1мм	ap=2мм	ap=2.5мм	ap=3мм	ap=3.5мм	ap=4мм	ap=5мм	ap=6мм	ap=8мм	ap=10мм
FMR1000	08	18.14	3	6	8	-	-	-	-	-	-	-
	10	11.7	5	10	12	-	-	-	-	-	-	-
	12	8.43	7	13	17	-	-	-	-	-	-	-
	15	5.93	10	19	24	-	-	-	-	-	-	-
FMR1500	10	20.67	21	5	7	8	-	-	-	-	-	-
	12	10.05	10	11	14	17	-	-	-	-	-	-
	16	6.12	6	19	23	28	-	-	-	-	-	-
	20	4.36	4	26	33	39	-	-	-	-	-	-
FMR2000	15	9.42	6	12	15	18	21	-	-	-	-	-
	20	5.85	10	20	24	29	34	-	-	-	-	-
FMR2500	16	13.7	4	8	10	12	14	16	-	-	-	-
	20	9.29	6	12	15	18	21	24	-	-	-	-
	25	6.56	9	17	22	26	30	35	-	-	-	-
FMR3000	25	21.8	3	5	6	8	9	10	13	-	-	-
	32	13.24	4	9	11	13	15	17	21	-	-	-
	40	9.09	6	13	16	19	22	25	31	-	-	-
	50	6.52	9	17	22	26	31	35	44	-	-	-
	63	4.76	12	24	30	36	42	48	60	-	-	-
	80	3.52	16	33	41	49	57	65	81	-	-	-
FMR4000	100	2.69	21	43	53	64	74	85	106	-	-	-
	32	15.95	3	7	9	10	12	14	17	21	-	-
	40	10.3	6	11	14	17	19	22	28	33	-	-
	50	7.13	8	16	20	24	28	32	40	48	-	-
	63	5.08	11	22	28	34	39	45	56	67	-	-
	80	3.69	16	31	39	47	54	62	78	93	-	-
FMR5000	100	2.79	21	41	51	62	72	82	103	123	-	-
	125	2.14	27	54	67	80	94	107	134	161	-	-
	40	7.4	8	15	19	23	27	31	38	46	62	-
	50	5.22	11	22	27	33	38	44	55	66	88	-
	63	3.79	15	30	38	45	53	60	75	91	121	-
	80	2.97	19	39	48	58	67	77	96	116	154	-
FMR6000	100	2.09	27	55	69	82	96	110	137	164	219	-
	125	1.63	35	70	88	105	123	141	176	211	281	-
	40	7.44	8	15	19	23	27	31	38	46	61	77
	50	4.97	11	23	29	34	40	46	57	69	92	46
	63	3.69	16	31	39	47	54	62	78	93	124	62
	80	2.72	21	42	53	63	74	84	105	126	168	84
FMR6000	100	2.12	27	54	68	81	95	108	135	162	216	108
	125	1.57	36	73	91	109	128	146	182	219	292	146



Выбор оптимального угла врезания для минимального диаметра винтовой линии DH min

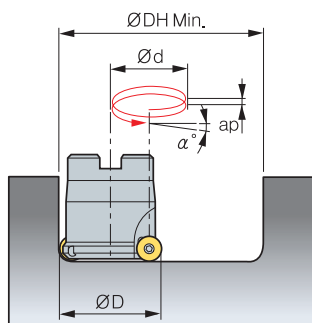

- ØD = Диаметр инструмента (мм), ØDH Min, Max = Min, Max Диаметр (мм)
- Ød = траектория инструмента (мм)
- $\text{ØDH Min (Min Диаметр)} = \text{ØD} \times 2 - \text{СМП size}$, $\text{ØDH Max (Max Диаметр)} = \text{ØD} \times 2 - 2$
- $\text{Ød (траектория инструмента)} = \text{ØDH Min, Max} - \text{ØD}$

Обозначение фрезы	Количество СМП	Диаметр фрезы	ØDH Min	Ød	Угол врезания (α°)									
					Шаг винтовой линии ar, мм									
					1	2	2.5	3	3.5	4	5	6	8	
FMR 1000	5	08	11	3	6.11	12.35	15.57	-	-	-	-	-	-	-
	5	10	15	5	3.65	7.34	7.34	-	-	-	-	-	-	-
	5	12	19	7	2.61	5.23	5.23	-	-	-	-	-	-	-
	5	15	25	10	1.83	3.65	3.65	-	-	-	-	-	-	-
FMR 1500	6	10	14	4	4.57	9.20	9.20	13.95	-	-	-	-	-	-
	6	12	18	6	3.04	6.11	6.11	9.20	-	-	-	-	-	-
	6	16	26	10	1.83	3.65	3.65	5.49	-	-	-	-	-	-
	6	20	34	14	1.30	2.61	2.61	3.92	-	-	-	-	-	-
FMR 2000	7	15	23	8	2.28	4.57	4.57	6.88	8.04	-	-	-	-	-
	7	20	33	13	1.40	2.81	2.81	4.22	4.92	-	-	-	-	-
FMR 2500	8	16	24	8	2.28	4.57	4.57	6.88	8.04	9.20	-	-	-	-
	8	20	32	12	1.52	3.04	3.04	4.57	5.34	6.11	-	-	-	-
	8	25	42	17	1.07	2.15	2.15	3.22	3.76	4.30	-	-	-	-
FMR 3000	10	25	40	15	1.22	2.43	2.43	3.65	4.27	4.88	6.11	-	-	-
	10	32	54	22	0.83	1.66	1.66	2.49	2.91	3.32	4.15	-	-	-
	10	40	70	30	0.61	1.22	1.22	1.83	2.13	2.43	3.04	-	-	-
	10	50	90	40	0.46	0.91	0.91	1.37	1.60	1.83	2.28	-	-	-
	10	63	116	53	0.34	0.69	0.69	1.03	1.21	1.38	1.72	-	-	-
	10	80	150	70	0.26	0.52	0.52	0.78	0.91	1.04	1.30	-	-	-
FMR 4000	12	32	52	20	0.91	1.83	1.83	2.74	3.20	3.65	4.57	5.49	-	-
	12	40	68	28	0.65	1.30	1.30	1.96	2.28	2.61	3.26	3.92	-	-
	12	50	88	38	0.48	0.96	0.96	1.44	1.68	1.92	2.40	2.88	-	-
	12	63	114	51	0.36	0.72	0.72	1.07	1.25	1.43	1.79	2.15	-	-
	12	80	148	68	0.27	0.54	0.54	0.81	0.94	1.07	1.34	1.61	-	-
	12	100	188	88	0.21	0.41	0.41	0.62	0.73	0.83	1.04	1.24	-	-
FMR 5000	12	125	238	113	0.16	0.32	0.32	0.48	0.57	0.65	0.81	0.97	-	-
	16	40	64	24	0.76	1.52	1.52	2.28	2.66	3.04	3.81	4.57	6.11	-
	16	50	84	34	0.54	1.07	1.07	1.61	1.88	2.15	2.69	3.22	4.30	-
	16	63	110	47	0.39	0.78	0.78	1.16	1.36	1.55	1.94	2.33	3.11	-
	16	80	144	64	0.29	0.57	0.57	0.86	1.00	1.14	1.43	1.71	2.28	-
	16	100	184	84	0.22	0.43	0.43	0.65	0.76	0.87	1.09	1.30	1.74	-
FMR 6000	16	125	234	109	0.17	0.33	0.33	0.50	0.59	0.67	0.84	1.00	1.34	-
	20	50	80	30	0.61	1.22	1.22	1.83	2.13	2.43	3.04	3.65	4.88	6.11
	20	63	106	43	0.42	0.85	0.85	1.27	1.49	1.70	2.12	2.55	3.40	4.25
	20	80	140	60	0.30	0.61	0.61	0.91	1.06	1.22	1.52	1.83	2.43	3.04
	20	100	180	80	0.23	0.46	0.46	0.68	0.80	0.91	1.14	1.37	1.83	2.28
	20	125	230	105	0.17	0.35	0.35	0.52	0.61	0.70	0.87	1.04	1.39	1.74
20	160	300	140	0.13	0.26	0.26	0.39	0.46	0.52	0.65	0.78	1.04	1.30	



Выбор оптимального угла врезания для максимального диаметра винтовой линии DH max

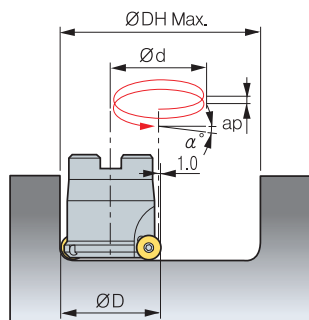

- ØD = (мм), ØDH Min, Max = Min, Max Диаметр(мм)
- Ød = траектория инструмента (мм)
- ØDH Min (Min Диаметр) = $\text{ØD} \times 2 - \text{СМП size}$, ØDH Max (Max Диаметр) = $\text{ØD} \times 2 - 2$
- Ød (траектория инструмента) = $\text{ØDH Min, Max} - \text{ØD}$

Обозначение фрезы	Количество СМП	Диаметр фрезы	ØDH Max	Ød	Угол врезания (α°)										
					Шаг винтовой линии ap, мм										
					1	2	2.5	3	3.5	4	5	6	8		
FMR 1000	5	08	14	6	3.04	6.11	7.65	-	-	-	-	-	-	-	-
	5	10	18	8	2.28	4.57	5.72	-	-	-	-	-	-	-	-
	5	12	22	10	1.83	3.65	4.57	-	-	-	-	-	-	-	-
	5	15	28	13	1.40	2.81	3.51	-	-	-	-	-	-	-	-
FMR 1500	6	10	18	8	2.28	4.57	5.72	6.88	-	-	-	-	-	-	-
	6	12	22	10	1.83	3.65	4.57	5.49	-	-	-	-	-	-	-
	6	16	30	14	1.30	2.61	3.26	3.92	-	-	-	-	-	-	-
	6	20	38	18	1.01	2.03	2.54	3.04	-	-	-	-	-	-	-
FMR 2000	7	15	28	13	1.40	2.81	3.51	4.22	4.92	-	-	-	-	-	-
	7	20	38	18	1.01	2.03	2.54	3.04	3.55	-	-	-	-	-	-
FMR 2500	8	16	30	14	1.30	2.61	3.26	3.92	4.57	5.23	-	-	-	-	-
	8	20	38	18	1.01	2.03	2.54	3.04	3.55	4.06	-	-	-	-	-
	8	25	48	23	0.79	1.59	1.98	2.38	2.78	3.18	-	-	-	-	-
FMR 3000	10	25	48	23	0.79	1.59	1.98	2.38	2.78	3.18	3.97	-	-	-	-
	10	32	62	30	0.61	1.22	1.52	1.83	2.13	2.43	3.04	-	-	-	-
	10	40	78	38	0.48	0.96	1.20	1.44	1.68	1.92	2.40	-	-	-	-
	10	50	98	48	0.38	0.76	0.95	1.14	1.33	1.52	1.90	-	-	-	-
	10	63	124	61	0.30	0.60	0.75	0.90	1.05	1.20	1.50	-	-	-	-
	10	80	158	78	0.23	0.47	0.58	0.70	0.82	0.94	1.17	-	-	-	-
	10	100	198	98	0.19	0.37	0.47	0.56	0.65	0.74	0.93	-	-	-	-
FMR 4000	12	32	62	30	0.61	1.22	1.52	1.83	2.13	2.43	3.04	3.65	-	-	-
	12	40	78	38	0.48	0.96	1.20	1.44	1.68	1.92	2.40	2.88	-	-	-
	12	50	98	48	0.38	0.76	0.95	1.14	1.33	1.52	1.90	2.28	-	-	-
	12	63	124	61	0.30	0.60	0.75	0.90	1.05	1.20	1.50	1.80	-	-	-
	12	80	158	78	0.23	0.47	0.58	0.70	0.82	0.94	1.17	1.40	-	-	-
	12	100	198	98	0.19	0.37	0.47	0.56	0.65	0.74	0.93	1.12	-	-	-
	12	125	248	123	0.15	0.30	0.37	0.45	0.52	0.59	0.74	0.89	-	-	-
FMR 5000	16	40	78	38	0.48	0.96	1.20	1.44	1.68	1.92	2.40	2.88	3.85	-	-
	16	50	98	48	0.38	0.76	0.95	1.14	1.33	1.52	1.90	2.28	3.04	-	-
	16	63	124	61	0.30	0.60	0.75	0.90	1.05	1.20	1.50	1.80	2.39	-	-
	16	80	158	78	0.23	0.47	0.58	0.70	0.82	0.94	1.17	1.40	1.87	-	-
	16	100	198	98	0.19	0.37	0.47	0.56	0.65	0.74	0.93	1.12	1.49	-	-
	16	125	248	123	0.15	0.30	0.37	0.45	0.52	0.59	0.74	0.89	1.19	-	-
FMR 6000	20	50	98	48	0.38	0.76	0.95	1.14	1.33	1.52	1.90	2.28	3.04	3.81	-
	20	63	124	61	0.30	0.60	0.75	0.90	1.05	1.20	1.50	1.80	2.39	2.99	-
	20	80	158	78	0.23	0.47	0.58	0.70	0.82	0.94	1.17	1.40	1.87	2.34	-
	20	100	198	98	0.19	0.37	0.47	0.56	0.65	0.74	0.93	1.12	1.49	1.86	-
	20	125	248	123	0.15	0.30	0.37	0.45	0.52	0.59	0.74	0.89	1.19	1.48	-
	20	160	318	158	0.12	0.23	0.29	0.35	0.40	0.46	0.58	0.69	0.92	1.16	-



FMAC(M) 3000



Рис. 1



Рис. 2

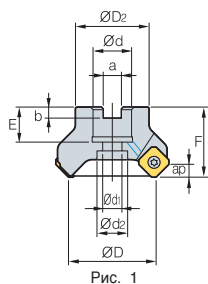

• AR : 21°
• RR : -17°~12°

(мм)

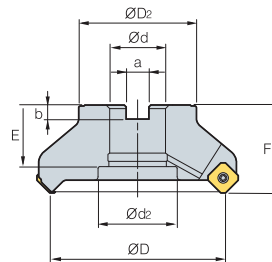
Обозначение		$\varnothing D$	$\varnothing D_2$	$\varnothing d$	a	b	E	F	$\varnothing d_1$	$\varnothing d_2$	ap		Рис.
FMAC(M) 3050HR	4	50	42	22	10.4	6.3	20	40	11	17.5	4.0	0.4	1
3050HR-H	6	50	42	22	10.4	6.3	20	40	11	17.5	4.0	0.4	1
3063HR	5	63	49	22	10.4	6.3	20	40	11	17.5	4.0	0.5	1
3063HR-H	8	63	49	22	10.4	6.3	20	40	11	17.5	4.0	0.6	1
3080HR	6	80	57	25.4(27)	9.5(12.4)	6(7)	25(23)	50	14	20	4.0	1.1	1
3080HR-H	10	80	57	25.4(27)	9.5(12.4)	6(7)	25(23)	50	14	20	4.0	1.2	1
3100HR	7	100	67	31.75(32)	12.7(14.4)	8(8)	35(25.5)	50	(18)	45(26)	4.0	1.7	2(1)
3100HR-H	12	100	67	31.75(32)	12.7(14.4)	8(8)	35(25.5)	50	(18)	45(26)	4.0	1.7	2(1)
3125HR	8	125	87	38.1(40)	15.9(16.4)	10(9)	42(29)	63	(22)	55(32)	4.0	3.3(3.5)	2(1)
3125HR-H	14	125	87	38.1(40)	15.9(16.4)	10(9)	42(29)	63	(22)	55(32)	4.0	3.3(3.5)	2(1)

• () Метрическая система

Применяемые СМП

SEET-MF	SEET-MM	SEET-MA	SEXT-MF	SEXT-MM	SEXT-MR	SEEW	SEEW-W											
Обозначение	Тв. сплав с покрытием								Кермет			Тв. сплав		Стр.				
	NCM325	NCM335	NC5330	PC3500	PC5300	PC5400	PC9530	PC6510	PC215K	PD2000	CN2000	CN20	CN30		H01	G10	ST30A	ST20
SEET 0903AGFN-MA																		
SEET 0903AGSN-MF	•																	
SEET 0903AGSN-MM	•																	
SEXT 0903AGSN-MF					•	•												
SEXT 0903AGSN-MM				•	•	•												
SEXT 0903AGSN-MR																		
SEEW 0903AGTN													•					

Применяемые оправки

Обозначение	$\varnothing d$	Оправка с хвостиком ВТ
FMAC(M) 3050HR-□ 3063HR-□	22	ВТ□□-FMC22-□□
3080HR-□	25.4 27	ВТ□□-FMA25.4-□□ ВТ□□-FMC27-□□
3100HR-□	31.75 32	ВТ□□-FMA31.75-□□ ВТ□□-FMC32-□□
3125HR-□	38.1 40	ВТ□□-FMA38.1-□□ ВТ□□-FMB / FMC40-□□

Комплектующие

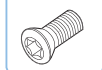

ФТКА0307



ТW09S

FMAC(M) 4000



Рис. 1



Рис. 2

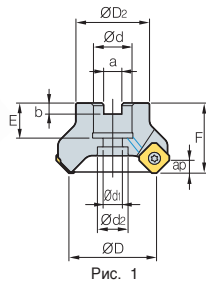

Рис. 3

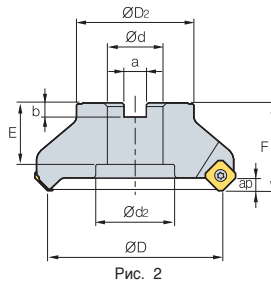

• AR : 21°
• RR : -17°~12°

(мм)

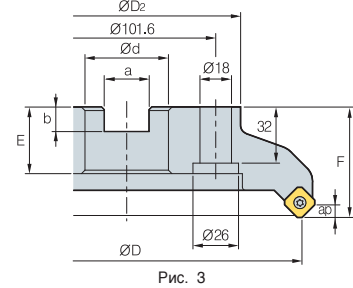
Обозначение		ØD	ØD ₂	Ød	a	b	E	F	Ød ₁	Ød ₂	ap	kg	Рис.
FMAC(M) 4050HR	3	50	42	22	10.4	6.3	20	40	11	18	6.5	0.4	1
4063HR	4	63	49	22	10.4	6.3	20	40	11	18	6.5	0.6	1
4063HR-M	5	63	49	22	10.4	6.3	20	40	11	18	6.5	0.6	1
4063HR-H	6	63	49	22	10.4	6.3	20	40	11	18	6.5	0.6	1
4080HR	5	80	57	25.4(27)	9.5(12.4)	6(7)	25(23)	50	14	20	6.5	1.1	1
4080HR-M	6	80	57	25.4(27)	9.5(12.4)	6(7)	25(23)	50	14	20	6.5	1.1	1
4080HR-H	8	80	57	25.4(27)	9.5(12.4)	6(7)	25(23)	50	18	20	6.5	1.1	1
4100HR	5	100	67	31.75(32)	12.7(14.4)	8(8)	33(25)	63(50)	18	26	6.5	2(1.6)	1
4100HR-M	7	100	67	31.75(32)	12.7(14.4)	8(8)	33(25)	63(50)	18	26	6.5	2(1.6)	1
4100HR-H	10	100	67	31.75(32)	12.7(14.4)	8(8)	33(25)	63(50)	18	26	6.5	2(1.6)	1
4125HR	6	125	87	38.1(40)	15.9(16.4)	10(9)	35(29)	63	22	32	6.5	3.1	1
4125HR-M	8	125	87	38.1(40)	15.9(16.4)	10(9)	35(29)	63	22	32	6.5	3.1	1
4125HR-H	12	125	87	38.1(40)	15.9(16.4)	10(9)	35(29)	63	22	32	6.5	3.1	1
4160R	7	160	107	50.8(40)	19.0(16.4)	11(9)	38(35)	63	-	-	6.5	4.8	2
4160R-M	10	160	107	50.8(40)	19.0(16.4)	11(9)	38(35)	63	-	-	6.5	4.8	2
4160R-H	16	160	107	50.8(40)	19.0(16.4)	11(9)	38(35)	63	-	-	6.5	4.8	2
4200R	8	200	130	47.625(60)	25.4(25.7)	14	38(32)	63	-	-	6.5	6.1	3
4200R-M	12	200	130	47.625(60)	25.4(25.7)	14	38(32)	63	-	-	6.5	6.1	3
4200R-H	18	200	130	47.625(60)	25.4(25.7)	14	38(32)	63	-	-	6.5	6.1	3

* () Метрическая система

Применяемые СМП

SEET-MF	SEET-MM	SEET-MA	SEXT-MF						
SEXT-MM	SEXT-MR	SEEW	SEEW-W						
Обозначение	Тв. сплав с покрытием				Кермет		Тв. сплав		Стр.
	NCM325	NCM335	NC5330	PC3500	PC3400	PC3630	PC6510	PC275K	
	PC2000	CN2000	CN30	H01	G10	ST30A	ST20		
SEET 14M4AGFN-MA									E15 E16
14M4AGSN-MF	●	●	●	●					
14M4AGSN-MM	●	●	●	●					
SEXT 14M4AGSN-MF	●	●	●	●					
14M4AGSN-MM	●	●	●	●					
14M4AGSN-MR	●	●	●	●					
SEEW 14M4AGTN									
14M4AGFN-W									
14M4AGSN-W									
14M4AGTN-W									

Применяемые оправки

Обозначение	Ød	Оправка с хвостовиком BT
FMAC(M) 4050HR-□	22	BT□□-FMC22-□□
4063HR-□		BT□□-FMC27-□□
4080HR-□	25.4	BT□□-FMA25.4-□□
	27	BT□□-FMC27-□□
4100HR-□	31.75	BT□□-FMA31.75-□□
	32	BT□□-FMC32-□□
4125HR-□	38.1	BT□□-FMA38.1-□□
	40	BT□□-FMB40-□□
4160R-□	50.8	BT□□-FMA50.8-□□
	40	BT□□-FMB / FMC40-□□
4200R-□	47.625	BT□□-FMA47.625-□□
	60	BT□□-FMB60-□□

Комплектующие



FTGA03512

SS42SAF

SHXN0509F

TW15S

HW35L



FMAC(M) 3000-A

(Алюминевый корпус)



Рис. 1



Рис. 2

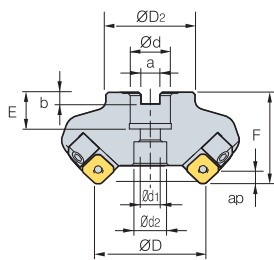

AA
45°

• AR : 21°
• RR : -16°~12°

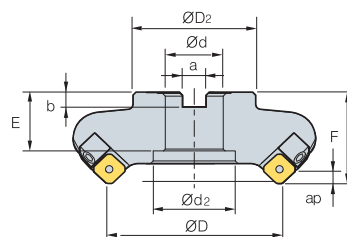
(мм)

Обозначение		$\varnothing D$	$\varnothing D_2$	$\varnothing d$	a	b	E	F	$\varnothing d_1$	$\varnothing d_2$	ap		Рис.
FMAC(M) 3063R-A	3	63	49	22	10.4	6.3	20	40	11	18	4	0.5	1
3080R-A	4	80	57	25.4(27)	9.5(12.4)	6(7)	25	50	13.5	20	4	0.6	1
3100R-A	5	100	67	31.75(32)	12.7(14.4)	8(8)	32	50	-	45	4	0.8	2
3100R-25.4-A	5	100	67	25.4	9.5	6	25	50	-	38	4	0.9	2
3125R-A	6	125	87	38.1(40)	15.9(16.4)	10(9)	38	63	-	56	4	1.6	2
3125R-25.4-A	6	125	70	25.4	9.5	6	25	63	-	38	4	1.7	2

• () Метрическая система

Применяемые СМП

	SEET-MF	SEET-MM	SEET-MA	SEXT-MF	SEXT-MM	SEXT-MR	SEEW											
Обозначение	Тв. сплав с покрытием						Кермет			Тв. сплав		Стр.						
	NCM325	NCM335	NC5330	PC3500	PC5300	PC5400	PC9530	PC6510	PC215K	PD2000	CN2000		CN20	CN30	H01	G10	ST30A	ST20
SEET 0903AGFN-MA														•				E15 E16
0903AGSN-MF	•																	
0903AGSN-MM	•				•													
SEXT 0903AGSN-MF					•	•												
0903AGSN-MM				•	•	•												
0903AGSN-MR				•	•	•		•	•									
SEEW 0903AGTN												•						

Применяемые оправки

Обозначение	$\varnothing d$	Оправка с хвостовиком ВТ
FMAC(M) 3063R-□	22	ВТ□□-FMC22-□□
3080R-□	25.4	ВТ□□-FMA25.4-□□
	27	ВТ□□-FMC27-□□
3100R-□	31.75	ВТ□□-FMA31.75-□□
	32	ВТ□□-FMC32-□□
3125R-□	38.1	ВТ□□-FMA38.1-□□
	40	ВТ□□-FMB40-□□

Комплектующие



FTKA0307

TW09S

HW30L

LFMA3R-A

DHA620



Применяемые СМП E15, E16



Присоединительные размеры смотреть на стр. E270~E272

• : Наличие на складе

FMAC(M) 4000-A

(Алюминевый корпус)



Рис. 1



Рис. 2

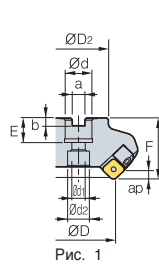

Рис. 3

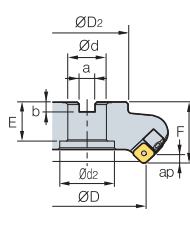

Рис. 4

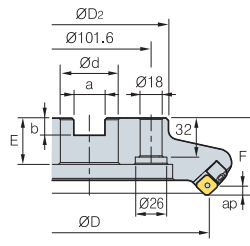

AA
45°
• AR : 21°
• RR : -16°~-12°

Обозначение		$\varnothing D$	$\varnothing D_2$	$\varnothing d$	a	b	E	F	$\varnothing d_1$	$\varnothing d_2$	ap		Рис.
FMAC(M) 4063R-A	3	63	49	22	10.4	6.3	20	50	11	18	6.5	0.6	1
4080R-A	4	80	67	25.4(27)	9.5(12.4)	6(7)	25(22)	50	13.5	20	6.5	0.8	1
4100R-A	5	100	67	31.75(32)	12.7(14.4)	8(8)	32	50	-	45	6.5	1.1	2
4100R-25.4-A	5	100	67	25.4	9.5	6	25	50	-	38	6.5	1.2	2
4125R-A	6	125	87	38.1(40)	15.9(16.4)	10(9)	38(35)	63	-	56	6.5	1.7	2
4125R-25.4-A	6	125	70	25.4	9.5	6	25	63	-	38	6.5	1.8	2
4160R-A	7	160	107	50.8(40)	19.0(16.4)	11(9)	38(35)	63	-	75	6.5	2.5	2
4200R-A	8	200	130	47.625(60)	25.4(25.7)	14(14)	38(32)	63	-	-	6.5	3.2	3
4250R-A	10	250	180	47.625(60)	25.4(25.7)	14(14)	38	63	-	-	6.5	4.1	3
4315R-A	12	315	240	47.625(60)	25.4(25.7)	14(14)	38	63	-	-	6.5	6.7	4

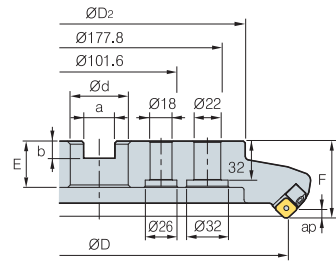
(мм)

Note) Through coolant Тип between $\varnothing 50$ ~ $\varnothing 125$

• () Метрическая система

Применяемые СМП

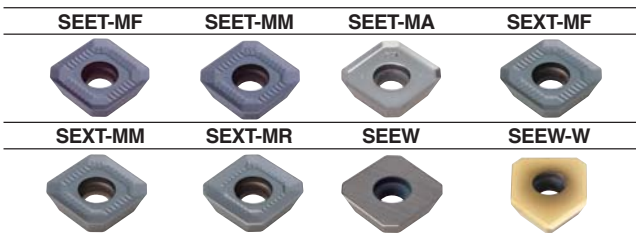

Обозначение	Тв. сплав с покрытием				Кермет		Тв. сплав		Стр.						
	NCM325	NCM335	PC3500	PC5300	PC9530	PC215K	PD2000	CN2000		CN20	CN30	H01	G10	ST30A	ST20
SEET 14M4AGFN-MA															
14M4AGSN-MF	●	●	●	●	●	●	●	●							
14M4AGSN-MM	●	●	●	●	●	●	●	●							
SEXT 14M4AGSN-MF	●	●	●	●	●	●	●	●							
14M4AGSN-MM	●	●	●	●	●	●	●	●							
14M4AGSN-MR	●	●	●	●	●	●	●	●							
SEEW 14M4AGTN											●				
14M4AGFN-W															
14M4AGSN-W															
14M4AGTN-W															

Применяемые оправки

Обозначение	$\varnothing d$	Оправка с хвостовиком BT
FMAC(M) 4063R-□	22	BT□□-FMC22-□□
	25.4	BT□□-FMA25.4-□□
4080R-□	27	BT□□-FMC27-□□
	31.75	BT□□-FMA31.75-□□
4100R-□	32	BT□□-FMC32-□□
	38.1	BT□□-FMA38.1-□□
4125R-□	40	BT□□-FMB40-□□
	50.8	BT□□-FMA50.8-□□
4160R-□	40	BT□□-FMB / FMC40-□□
4200R-□	47.625	BT□□-FMA47.625-□□
4250R-□	60	BT□□-FMB60-□□
4315R-□	60	BT□□-FMB60-□□

Комплектующие

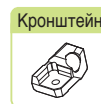
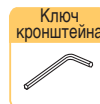

FTGA03512

TW15S

HW40L

LFMA4R-A

DHA0830

Применяемые СМП E15, E16

Присоединительные размеры смотреть на стр. E270~E272

● : Наличие на складе



FMAS3000

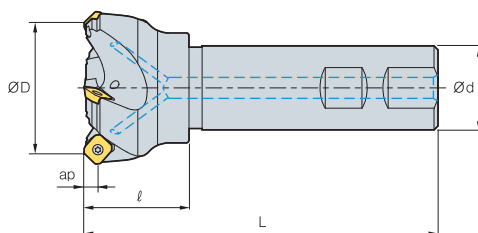

• AR : 23°
• RR : -17°~13°

(MM)

Обозначение		ØD	Ød	l	L	ap	
FMAS							
3025HR	2	25	25	35	115	4	0.4
3032HR	3	32	25	40	125	4	0.5
3032HR-S32	3	32	32	40	130	4	0.8
3040HR	3	40	32	40	130	4	0.9
3040HR-S40	3	40	40	40	140	4	1.3
3040HR-S42	3	40	42	40	140	4	1.4
3050HR	4	50	32	40	135	4	1
3050HR-S40	4	50	40	40	140	4	1.3
3050HR-S42	4	50	42	40	140	4	1.5
3063HR	5	63	32	45	135	4	1.2
3063HR-S40	5	63	40	45	145	4	1.6
3063HR-S42	5	63	42	45	145	4	1.7

• () Метрическая система

Применяемые СМП

	SEET-MF	SEET-MM	SEET-MA	SEXT-MF	SEXT-MM	SEXT-MR	SEEW	SEEW-W											
Обозначение	Тв. сплав с покрытием									Стр.									
	NCM325	NCM335	NC5330	PC3500	PC5300	PC5345	PC9530	PC6510	PC215K		PD2000	Кермет		Тв. сплав					
SEET 0903AGFN-MA																			
SEET 0903AGSN-MF	●																		
SEET 0903AGSN-MM	●				●														
SEXT 0903AGSN-MF					●	●													
SEXT 0903AGSN-MM				●	●	●		●	●										
SEXT 0903AGSN-MR																			
SEEW 0903AGTN												●							

Комплектующие



ФТКА0307



TW09S

FMAS4000

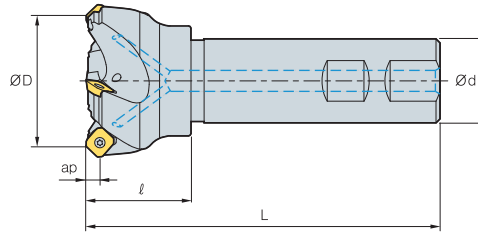

• AR : 23°
• RR : -17°~-13°

(мм)

Обозначение		ØD	Ød	l	L	ap	
FMAS 4050HR	3	50	32	45	135	6.5	1
4050HR-S40	3	50	40	45	135	6.5	1.3
4050HR-S42	3	50	42	45	135	6.5	1.45
4063HR	4	63	32	45	135	6.5	1.2
4063HR-S40	4	63	40	45	135	6.5	1.5
4063HR-S42	4	63	42	45	135	6.5	1.6

• () Метрическая система

Применяемые СМП

SEET-MF	SEET-MM	SEET-MA	SEXT-MF	SEXT-MM	SEXT-MR	SEEW	SEEW-W											
Обозначение	Тв. сплав с покрытием								Кермет			Тв. сплав				Стр.		
	NCM325	NCM335	NC5330	PC3500	PC5300	PC5445	PC9530	PC6510	PC215K	PD2000	CN2000	CN20	CN30	H01	G10		ST30A	ST20
SEET 14M4AGFN-MA										●								
14M4AGSN-MF	●	●			●			●	●									
14M4AGSN-MM	●	●		●	●			●										
SEXT 14M4AGSN-MF	●			●	●	●			●									
14M4AGSN-MM	●	●		●	●	●		●	●	●								
14M4AGSN-MR	●			●	●													
SEEW 14M4AGTN								●					●					
14M4AGFN-W																		
14M4AGSN-W																		
14M4AGTN-W																		

Комплектующие

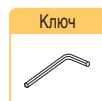

FTGA03512

SS42SAF

SHXN0509F

TW15S

HW35L



FMPC(M) 3000

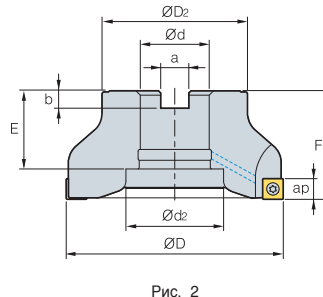
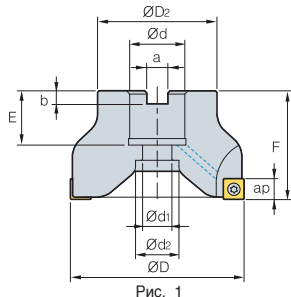
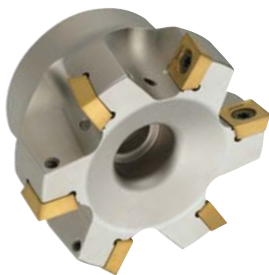

(мм)

Обозначение		$\varnothing D$	$\varnothing D_2$	$\varnothing d$	a	b	E	F	$\varnothing d_1$	$\varnothing d_2$	ap		Рис.
FMPC(M) 3050HS	5	50	40	22	10.4	6.3	20	40	11	18	7	0.3	1
3063HS	6	63	40	22	10.4	6.3	20	40	11	18	7	0.5	1
3080HS	7	80	55	25.4(27)	9.5(12.4)	6(7)	25(22)	50	14	20	7	1.0	1
3100HS	8	100	67	31.75(32)	12.7(14.4)	8(8)	36(26)	50	18	45(26)	7	1.5	2(1)

• () Метрическая система

Применяемые СМП

	SDET-MF	SDET-MM	SDET-MA	SDXT-MF	SDXT-MM	SDXT-MA												
Обозначение	Тв. сплав с покрытием							Стр.										
	NCM825	NCM835	NC5330	PC3500	PC5300	PC5400	PC3545											
SDET 09M402R-MA								●										
09M405R-MF																		
09M405R-MM																		
SDXT 09M405R-MF	●	●			●	●												
09M405L-MF																		
09M405R-MM	●	●		●	●	●												
09M405L-MM																		
09M405R-MA														●				

Применяемые оправки

Обозначение	$\varnothing d$	Оправка с хвостовиком ВТ
FMPC(M) 3050HS	22	ВТ□□-FMC22-□□
3063HS	25.4	ВТ□□-FMA25.4-□□
3080HS	27	ВТ□□-FMC27-□□
3100HS	31.75	ВТ□□-FMA31.75-□□
	32	ВТ□□-FMC32-□□

Комплектующие

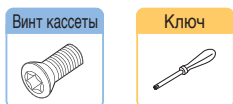

FTGA03508 TW15S

Схема сборки

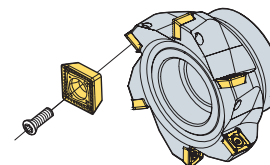

FMPC(M)4000



Рис. 1



• AR : 10°
• RR : -9°~8°

(мм)

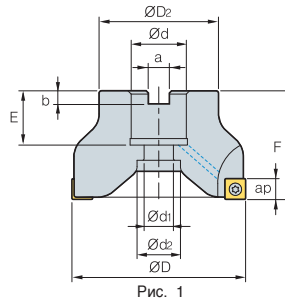
Обозначение		øD	øD ₂	ød	a	b	E	F	ød ₁	ød ₂	ap		Рис.
FMPC(M) 4063HS	5	63	49	22	10.4	6.3	20(20)	50(50)	11	18	11	0.4	1
4080HS	6	80	57	25.4(27)	9.5(12.4)	6(7)	25(23)	50(50)	14	20	11	0.9	1
4100HS	7	100	67	31.75(32)	12.7(14.4)	8(8)	33(25)	63(50)	18	26	11	1.9(1.5)	1
4125HS	8	125	87	38.1(40)	15.9(16.4)	10(9)	35(29)	63	22	32	11	3.1	1

• () Метрическая система

Применяемые СМП

	SDET-MF	SDET-MM	SDET-MA	SDXT-MF	SDXT-MM	SDXT-MA												
Обозначение	Тв. сплав с покрытием									Кермет			Тв. сплав		Стр.			
	NCM625	NCM335	NC5330	PC3500	PC5300	PC5400	PC3545	PC9530	PC6510	PD2000	CN2000	CN20	CN30	H01		G10	ST30A	ST20
SDET 130504R-MA																		
130508R-MF																		
130508R-MM																		
SDXT 130508R-MF	•	•			•	•												
130508R-MM	•	•		•	•	•												
130538-MM																		
130508R-MA														•				

Применяемые оправки

Обозначение	Ød	Оправка с хвостовиком BT
FMPC(M) 4063HS	22	BT□□-FMC22-□□
4080HS	25.4	BT□□-FMA25.4-□□
	27	BT□□-FMC27-□□
4100HS	31.75	BT□□-FMA31.75-□□
	32	BT□□-FMC32-□□
4125HS	38.1	BT□□-FMA38.1-□□
	40	BT□□-FMB / FMC40-□□

Комплектующие

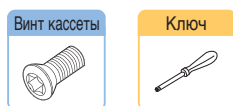

FTNC04511 TW20S

Схема сборки

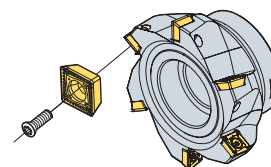

FMPC(M) 3000-A

(Алюминиевый корпус)



Рис. 1



Рис. 2

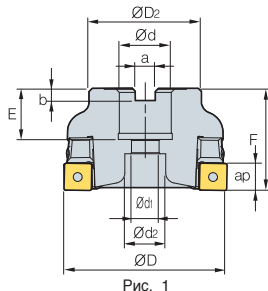
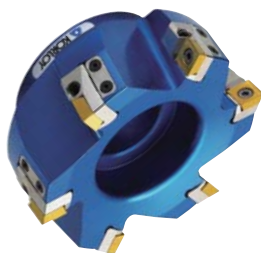

• AR : 10°
• RR : -9°~-7.3°

(мм)

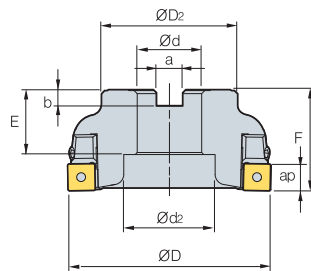
Обозначение		$\varnothing D$	$\varnothing D_2$	$\varnothing d$	a	b	E	F	$\varnothing d_1$	$\varnothing d_2$	a_p		Рис.	
FMPC(M) 3063S-A		3	63	40	22	10.4	6.3	20	40	11.0	18	4	0.2	1
3080S-A		4	80	55	25.4(27)	9.5(12.4)	6(7)	25(22)	50	13.5	20	4	0.4	1
3100S-A		5	100	67	31.75(32)	12.7(14.4)	8(8)	32	50	-	45	4	0.6	2
3100S-25.4-A		5	100	67	25.4	9.5	6	25	50	-	38	4	0.7	2

• () Метрическая система

Применяемые СМП

	SDET-MF	SDET-MM	SDET-MA	SDXT-MF	SDXT-MM	SDXT-MA												
Обозначение	Тв. сплав с покрытием							Кермет			Тв. сплав			Стр.				
	NCM325	NCM335	NC5330	PC3500	PC5300	PC5400	PC3545	PC9530	PC6510	PD2000	CN2000	CN20	CN30	H01	G10	ST30A	ST20	
SDET 09M402R-MA										●								
SDET 09M405R-MF																		
SDET 09M405R-MM																		
SDXT 09M405R-MF	●	●			●	●												
SDXT 09M405L-MF																		
SDXT 09M405R-MM	●	●		●	●	●												
SDXT 09M405L-MM																		
SDXT 09M405R-MA																		

Применяемые оправки

Обозначение	$\varnothing d$	Оправка с хвостовиком ВТ
FMPC(M) 3063S-□	22	ВТ□□-FMC22-□□
3080S-□	25.4	ВТ□□-FMA25.4-□□
3100S-□	27	ВТ□□-FMC27-□□
3100S-□	31.75	ВТ□□-FMA31.75-□□
3125S-□	32	ВТ□□-FMC32-□□
	38.1	ВТ□□-FMA38.1-□□
	40	ВТ□□-FMB / FMC40-□□

Комплектующие

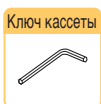

3063S-A	FTGA03508	TW15S	HW30L	LFMP3R-A	DHA0624	CFMP3R14R1-A	PXMA0306
3080S-A ~ 3100S-A	FTGA03508	TW15S	HW30L	LFMP3R-A	DHA0624	CFMP3R-A	PXMA0306

FMPC(M) 4000-A

(Алюминиевый корпус)

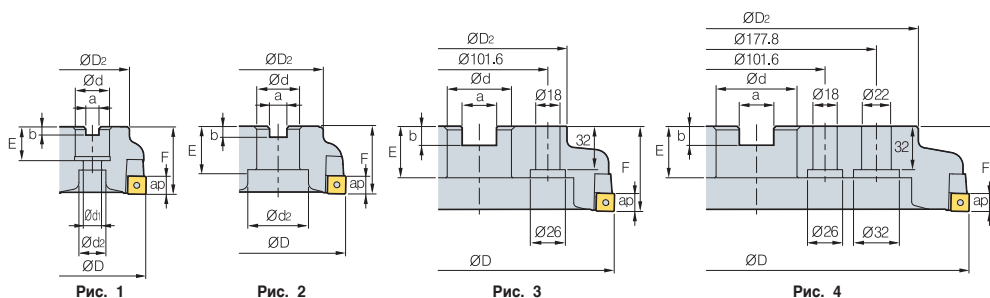
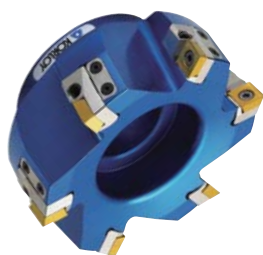

• AR : 10°
• RR : -9°~-7.3°

Обозначение	ØD	ØD ₂	Ød	a	b	E	F	Ød ₁	Ød ₂	ap	kg	Рис.
FMPC(M) 4063S-A	63	49	22	10.4	6.3	20	50	11	18	6.5	0.6	1
4080S-A	80	67	25.4(27)	9.5(12.4)	6(7)	25(22)	50	13.5	20	6.5	0.8	1
4100S-A	100	67	31.75(32)	12.7(14.4)	8(8)	32	50	-	45	6.5	1.1	2
4100S-25.4-A	100	67	25.4	9.5	6	25	50	-	38	6.5	1.2	2
4125S-A	125	87	38.1(40)	15.9(16.4)	10(9)	38(35)	63	-	56	6.5	1.7	2
4125S-25.4-A	125	70	25.4	9.5	6	25	63	-	38	6.5	1.8	2
4160S-A	160	107	50.8(40)	19.0(16.4)	11(9)	38(35)	63	-	75	6.5	2.5	2
4200S-A	200	130	47.625(60)	25.4(25.7)	14(14)	38(32)	63	-	-	6.5	3.2	3
4250S-A	250	180	47.625(60)	25.4(25.7)	14(14)	38	63	-	-	6.5	4.1	3
4315S-A	315	240	47.625(60)	25.4(25.7)	14(14)	38	63	-	-	6.5	6.7	4

() Метрическая система

Применяемые СМП

Обозначение	Тв. сплав с покрытием	Кермет	Тв. сплав	Стр.
SDET	NCM325 NCM335 NC5330 PC3500 PC3600 PC3940 PC3545 PC9530 PC8510 PD2000 CN2000	CN20 CN30	H01 G10 ST30A ST20	E13 E14 E15
SDXT	NCM325 NCM335 NC5330 PC3500 PC3600 PC3940 PC3545 PC9530 PC8510 PD2000 CN2000	CN20 CN30	H01 G10 ST30A ST20	E13 E14 E15

Применяемые оправки

Обозначение	Ød	Оправка с хвостовиком ВТ
FMPC(M) 4063S-□	22	ВТ□□-FMC22-□□
4080S-□	25.4	ВТ□□-FMA25.4-□□
	27	ВТ□□-FMC27-□□
4100S-□	31.75	ВТ□□-FMA31.75-□□
	32	ВТ□□-FMC32-□□
4125S-□	38.1	ВТ□□-FMA38.1-□□
	40	ВТ□□-FMB40-□□
4160S-□	50.8	ВТ□□-FMA50.8-□□
	40	ВТ□□-FMB / FMC40-□□
4200S-□	47.625	ВТ□□-FMA47.625-□□
4250S-□	60	ВТ□□-FMB60-□□
4315S-□	60	ВТ□□-FMB60-□□

Комплектующие



4063S-A ~ 4080S-A	FTNC04509	TW20S	HW40L	LFMP4R1-A	DHA0825	CFMP3R14R1-A	PXMA0306
4100S-A ~ 4315S-A	FTNC04509	TW20S	HW40L	LFMP4R-A	DHA0830	CFMP4R-A	PXMA0306

Применяемые СМП E13, E14, E15

Присоединительные размеры смотреть на стр. E270~E272

● : Наличие на складе



FMPS3000

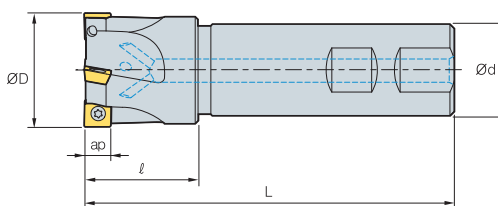

Обозначение		$\varnothing D$	$\varnothing d$	l	L	ap	
FMPS							(мм)
3025HS	2	25	25	35	115	7	0.4
3032HS	3	32	25	40	125	7	0.5
3040HS	4	40	32	40	130	7	0.8
3040HS-S40	4	40	40	45	140	7	1.2
3040HS-S42	4	40	42	45	140	7	1.3
3050HS	5	50	32	40	135	7	1
3050HS-S40	5	50	40	40	140	7	1.3
3050HS-S42	5	50	42	40	140	7	1.4
3063HS	6	63	32	45	135	7	1.2
3063HS-S40	6	63	40	45	145	7	1.6
3063HS-S42	6	63	42	45	145	7	1.7

Применяемые СМП

	SDET-MF	SDET-MM	SDET-MA	SDXT-MF	SDXT-MM	SDXT-MA												
Обозначение	Тв. сплав с покрытием								Кермет			Тв. сплав				Стр.		
	NCM325	NCM335	NC5330	PC3500	PC5300	PC5400	PC3545	PC9530	PC6510	PD2000	CN2000	CN20	CN30	H01	G10		ST30A	ST20
SDET 09M402R-MA										●				●				E13 E14 E15
09M405R-MF																		
09M405R-MM																		
SDXT 09M405R-MF	●	●			●	●			●	●								
09M405L-MF																		
09M405R-MM	●	●		●	●	●		●	●									
09M405L-MM																		
09M405R-MA																		

Комплектующие

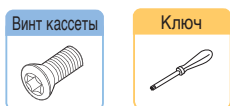

FTGA03508 TW15S

Схема сборки

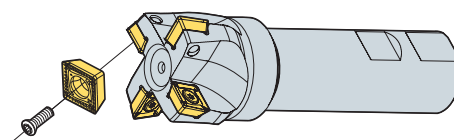

FMPS4000

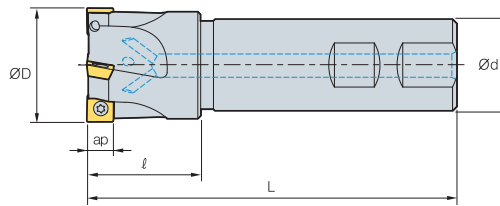

AA
90°
• AR : 10°
• RR : -9°~8°

(MM)

Обозначение		øD	ød	l	L	ap	
FMPS							
4040HS	3	40	32	40	130	11	1
4040HS-S40	3	40	40	40	140	11	1.3
4040HS-S42	3	40	42	40	140	11	1.4
4050HS	4	50	32	45	135	11	1.5
4050HS-S40	4	50	40	45	145	11	1.7
4050HS-S42	4	50	42	45	145	11	1.6
4063HS	5	63	32	45	135	11	2.1
4063HS-S40	5	63	40	45	145	11	2.4
4063HS-S42	5	63	42	45	145	11	2.6

Применяемые СМП

	SDET-MF	SDET-MM	SDET-MA	SDXT-MF	SDXT-MM	SDXT-MA												
Обозначение	Тв. сплав с покрытием									Кермет			Тв. сплав				Стр.	
	NCM325	NCM335	NC5330	PC3500	PC3300	PC5400	PC3545	PC9530	PC6510	PD2000	CN2000	CN20	CN30	H01	G10	ST30A		ST20
SDET 130504R-MA														•				
130508R-MF																		
130508R-MM																		
SDXT 130508R-MF	•	•			•	•			•	•								
130508R-MM	•	•		•	•	•	•	•	•									
130538-MM																		
130508R-MA														•				

Комплектующие

Винт кассеты



Ключ



FTNC04511

TW20S

Схема сборки

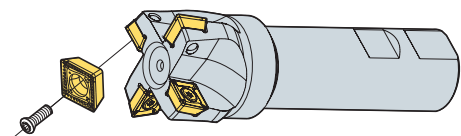

FMRC(M) 3000

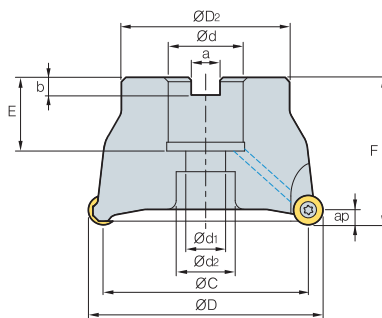

• AR : 5°
• RR : -5°

(MM)

Обозначение		ØD	ØC	ØD2	Ød	a	b	E	F	Ød1	Ød2	ap		
FMRC(M)	3040HRD	3	40	30	36	16	8.4	5.6	18	40	9	14	5.0	0.2
	3040HRD-H	4	40	30	36	16	8.4	5.6	18	40	9	14	5.0	0.2
	3050HRD	4	50	40	42	22	10.4	6.3	20	40	11	16.5	5.0	0.3
	3050HRD-H	5	50	40	42	22	10.4	6.3	20	40	11	16.5	5.0	0.3
	3063HRD	5	63	53	49	22	10.4	6.3	20	50	11	16.5	5.0	0.64
	3063HRD-H	6	63	53	49	22	10.4	6.3	20	50	11	16.5	5.0	0.64
	3080HRD	6	80	70	57	25.4(27)	9.5(12.4)	6(7.0)	25(22)	50(50)	14	19	5.0	1.1
	3080HRD-H	7	80	70	57	25.4(27)	9.5(12.4)	6(7.0)	25(22)	50(50)	14	19	5.0	1.1
	3100HRD	7	100	90	67	31.75(32)	12.7(14.4)	8(8.0)	32(28)	63(63)	18	26	5.0	2.1
	3100HRD-H	8	100	90	67	31.75(32)	12.7(14.4)	8(8.0)	32(28)	63(63)	18	26	5.0	2.1

Примечание) Это вообще, что вы измеряете внутренний диаметр когда диаметр FMRC / FMRCM является Ø40 ~ Ø63

• () Метрическая система

Применяемые СМП

Обозначение	RDKT-MF									RDKT-MM				RDCT-MA				Стр.	
	Тв. сплав с покрытием									Кермет				Тв. сплав					
	NCM325	NCM335	NC5330	PC3500	PC5300	PC3545	PC9530	PC6510	PC215K	PD2000	CN2000	CN20	CN30	H01	G10	ST30A	ST20		
RDCT 10T3M0-MA																			E12
RDKT 10T3M0-MF																			E13
10T3M0-MM																			

Применяемые оправки

Обозначение	Ød	Оправка с хвостовиком BT
FMRC(M) 3040HRD	16	BT□□-FMC16-□□
3040HRD-H		
3050HRD		
3050HRD-H		
3063HRD	22	BT□□-FMC22-□□
3063HRD-H		
3080HRD	25.4	BT□□-FMA / FMB25.4-□□
3080HRD-H	27	BT□□-FMB / FMC27-□□
3100HRD	31.75	BT□□-FMA31.75-□□
3100HRD-H	32	BT□□-FMC32-□□

Комплектующие



FTGA03508



TW15S



FMRC(M) 4000

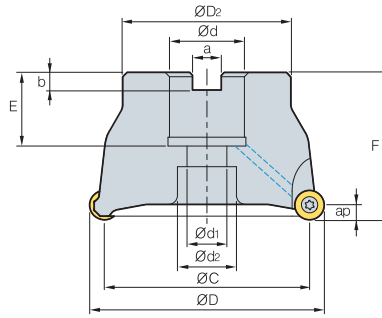

• AR : 5°
• RR : -5°

(MM)

Обозначение		ØD	ØC	ØD2	Ød	a	b	E	F	Ød1	Ød2	ap		
FMRC(M) 4050HRD		4	50	38	42	22	10.4	6.3	20	50	11	18	6.0	0.4
4063HRD		4	63	51	49	22	10.4	6.3	20	50	11	18	6.0	0.6
4063HRD-M		5	63	51	49	22	10.4	6.3	20	50	11	18	6.0	0.6
4080HRD		5	80	68	57	25.4(27)	9.5(12.4)	6(7.0)	25(23)	50(50)	14	20	6.0	1.0
4080HRD-M		6	80	68	57	25.4(27)	9.5(12.4)	6(7.0)	25(23)	50(50)	14	20	6.0	1.0
4100HRD		6	100	88	67	31.75(32)	12.7(14.4)	8(8.0)	33(25)	63(50)	18	26	6.0	1.9(1.5)
4100HRD-M		7	100	88	67	31.75(32)	12.7(14.4)	8(8.0)	33(25)	63(50)	18	26	6.0	1.9(1.5)
4125HRD		7	125	113	87	38.1(40)	15.9(16.4)	10(9.0)	35(29)	63(63)	22	32	6.0	3.0
4125HRD-M		8	125	113	87	38.1(40)	15.9(16.4)	10(9.0)	35(29)	63(63)	22	32	6.0	3.0

Примечание) Это вообще, что вы измеряете внутренний диаметр когда диаметр FMRC / FMRCM является Ø40 ~ Ø63

• () Метрическая система

Применяемые СМП

Обозначение	RDKT-MF			RDKT-MM						RDCT-MA			Стр.					
	NCM325	NCM335	NC5330	PC3500	PC5300	PC3545	PC9530	PC6510	PC215K	PD2000	CN2000	CN20		CN30	H01	G10	ST30A	ST20
RDCT 1204M0-MA																		
RDKT 1204M0-MF				•	•	•	•	•						•				
1204M0-MM	•	•	•	•	•	•	•	•										

Применяемые оправки

Обозначение	Ød	Оправка с хвостовиком ВТ
FMRC(M) 4050HRD	22	ВТ □□ -FMC22- □□
4063HRD		
4063HRD-M		
4080HRD	25.4	ВТ □□ -FMA / FMB25.4- □□
4080HRD-M		
4100HRD	31.75	ВТ □□ -FMA31.75- □□
4100HRD-M		
4125HRD	38.1	ВТ □□ -FMA / FMB38.1- □□
4125HRD-M		
	40	ВТ □□ -FMB / FMC40- □□

Комплектующие

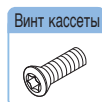

FTKA0410



TW15S



FMRC(M)5000



Рис. 1



Рис. 2

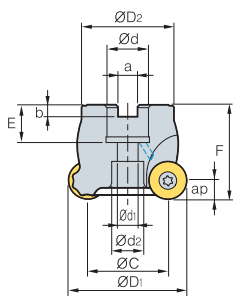

Рис. 3

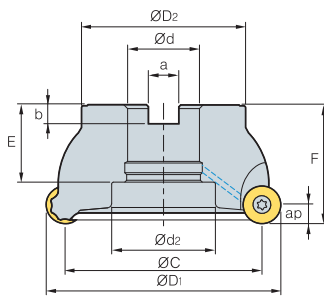

- AR : 5°
- RR : -5°

(мм)

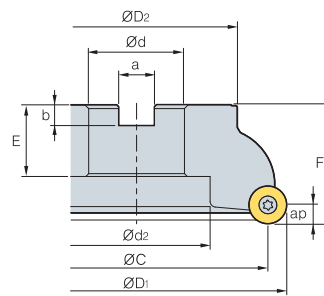
Обозначение		ØD	ØC	ØD2	Ød	a	b	E	F	Ød1	Ød2	ap		Рис.
FMRC(M) 5050HRD	3	50	34	42	22	10.4	6.3	20	50	11	16.5	8.0	0.4	1
5063HRD	4	63	47	49	22	10.4	6.3	20	50	11	18	8.0	0.6	1
5063HRD-H	5	63	47	49	22	10.4	6.3	20	50	11	18	8.0	0.6	1
5080HRD	5	80	64	57	25.4(27)	9.5(12.4)	6(7.0)	25(23)	50(50)	14	20	8.0	0.9	1
5080HRD-H	6	80	64	57	25.4(27)	9.5(12.4)	6(7.0)	25(23)	50(50)	14	20	8.0	0.9	1
5100HRD	6	100	84	67	31.75(32)	12.7(14.4)	8(8)	33(25)	63(50)	18	26	8.0	1.9(1.4)	1
5100HRD-H	7	100	84	67	31.75(32)	12.7(14.4)	8(8)	33(25)	63(50)	18	26	8.0	1.9(1.4)	1
5125HRD	7	125	109	87	38.1(40)	15.9(16.4)	10(9)	35(29)	63(63)	22	32	8.0	3	1
5125HRD-H	8	125	109	87	38.1(40)	15.9(16.4)	10(9)	35(29)	63(63)	22	32	8.0	3	1

Примечание) Это вообще, что вы измеряете внутренний диаметр когда диаметр FMRC / FMRCM является Ø40 ~ Ø63 - Ø160 не является внутренним теплоносителем

• () Метрическая система

Применяемые СМП

RDHW-E,F,S

RDKT-MM



Обозначение	Тв. сплав с покрытием									Кермет			Тв. сплав				Стр.	
	NCM325	NCM335	NC5330	PC3500	PC5300	PC3545	PC9530	PC6510	PC215K	PD2000	CN2000	CN20	CN30	H01	G10	ST30A		ST20
RDHW 1605M0E 1605M0F 1605M0S																		E13
RDKT 1605M0-MM 1605M0-ML				•		•												

Применяемые оправки

Обозначение	Ød	Оправка с хвостовиком BT
FMRC(M) 5050HRD	22	BT□□-FMC22-□□
5063HRD		
5063HRD-H		
5080HRD	25.4	BT□□-FMA / FMB25.4-□□
5080HRD-H	27	BT□□-FMB / FMC27-□□
5100HRD	31.75	BT□□-FMA31.75-□□
5100HRD-H	32	BT□□-FMC32-□□
5125HRD	38.1	BT□□-FMA / FMB38.1-□□
5125HRD-H	40	BT□□-FMB / FMC40-□□

Комплектующие

Винт кассеты



Ключ



FTGA0513-P

TW20-100

FMRC(M)6000



Рис. 1



Рис. 2

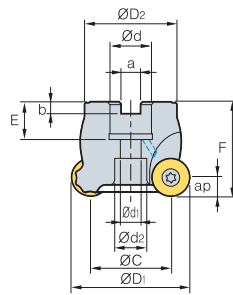

Рис. 3

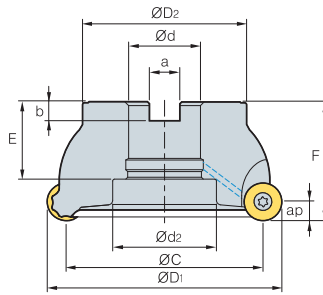

• AR : 5°
• RR : -5°

(MM)

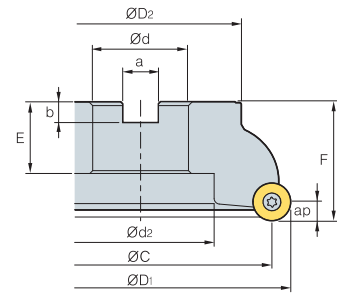
Обозначение	ØD	ØC	ØD2	Ød	a	b	E	F	Ød1	Ød2	ap	kg	Рис.
FMRC(M) 6063HRD	3	63	43	49	22	10.4	6.3	20	50	11	17	10.0	0.5 1
6063HRD-M	4	63	43	49	22	10.4	6.3	20	50	11	17	10.0	0.5 1
6080HRD	4	80	60	57	25.4(27)	9.5(12.4)	6(7.0)	25(22)	50	14	20	10.0	0.8 1
6080HRD-M	5	80	60	57	25.4(27)	9.5(12.4)	6(7.0)	25(22)	50	14	20	10.0	0.8 1
6100HRD	5	100	80	67	31.75(32)	12.7(14.4)	8(8)	32(28)	63	18	26	10.0	1.6 1
6100HRD-M	6	100	80	67	31.75(32)	12.7(14.4)	8(8)	32(28)	63	18	26	10.0	1.6 1
6125HRD	6	125	105	87	38.1(40)	15.9(16.4)	10(9)	41(29)	63	- (22)	55(32)	10.0	2.7(2.9) 2(1)
6125HRD-M	7	125	105	87	38.1(40)	15.9(16.4)	10(9)	41(29)	63	- (22)	55(32)	10.0	2.7(2.9) 2(1)
6160RD	7	160	140	107	50.8(40)	19(16.4)	11(9)	38(35)	63	-	78	10.0	4.4 3
6160RD-M	8	160	140	107	50.8(40)	19(16.4)	11(9)	38(35)	63	-	78	10.0	4.4 3

Примечание) Это вообще, что вы измеряете внутренний диаметр когда диаметр FMRC / FMRCM является Ø40 ~ Ø63 - Ø160 не является внутренним теплоносителем

• () Метрическая система

Применяемые СМП

RDHW-E,F,S

RDKT-MM



Обозначение	Тв. сплав с покрытием									Кермет			Тв. сплав				Стр.	
	NCM325	NCM335	NC5330	PC3500	PC3500	PC3545	PC9530	PC6510	PC215K	PD2000	CN2000	CN20	CN30	H01	G10	ST30A		ST20
RDHW 2006MOE																		E13
2006MOF																		
2006MOS																		
RDKT 2006MO-MM				●		●												

Применяемые оправки

Обозначение	Ød	Оправка с хвостовиком ВТ
FMRC(M) 6063HRD	22	ВТ□□-FMC22-□□
6063HRD-M		
6080HRD	25.4	ВТ□□-FMA / FMB25.4-□□
6080HRD-M	27	ВТ□□-FMB / FMC27-□□
6100HRD	31.75	ВТ□□-FMA31.75-□□
6100HRD-M	32	ВТ□□-FMC32-□□
6125HRD	38.1	ВТ□□-FMA / FMB38.1-□□
6125HRD-M	40	ВТ□□-FMB / FMC40-□□
6160RD	50.8	ВТ□□-FMA50.8-□□
6160RD-M	40	ВТ□□-FMB / FMC40-□□

Комплектующие



FTGA0515-P



TW20-100



FMRS1000/1500



Рис. 1



Рис. 2

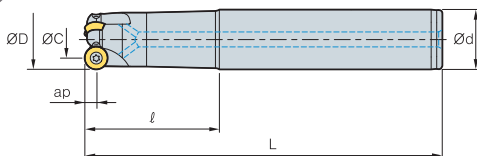

- AR : 5°
- RR : -5°~1°

(мм)

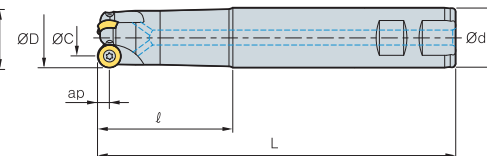
Обозначение		ØD	ØC	Ød	ℓ	L	ap		Рис.	
FMRS	1008HRD-M	1	8	5.5	10	30	80	2.5	0.2	1
	1008HRD-L	1	8	5.5	10	50	100	2.5	0.2	1
	1010HRD-M	2	10	5	12	44	100	2.5	0.2	1
	1010HRD-L	2	10	5	12	64	120	2.5	0.2	1
	1012HRD-M	2	12	7	12	44	100	2.5	0.3	1
	1012HRD-L	2	12	7	16	80	160	2.5	0.3	1
	1015HRD-M	3	15	10	16	80	160	2.5	0.3	1
	1015HRD-L	3	15	10	16	100	200	2.5	0.4	1
FMRS	1510HRD-M	1	10	6	12	44	100	3.0	0.2	1
	1510HRD-L	1	10	6	12	64	120	3.0	0.2	1
	1512HRD-M	2	12	6	12	54	110	3.0	0.3	1
	1512HRD-L	2	12	6	16	80	160	3.0	0.3	1
	1516HRD-M	3	16	10	16	60	130	3.0	0.3	1
	1516HRD-L	3	16	10	20	90	180	3.0	0.4	1
	1520HRD-M	3	20	14	20	80	150	3.0	0.4	1
	1520HRD-L	3	20	14	20	90	200	3.0	0.5	1

Применяемые СМП

RDHW-E,F,S

RDKW



Тип	Обозначение	Тв. сплав с покрытием								Кермет			Тв. сплав				Стр.		
		NCM325	NCM335	NC5330	PC3500	PC5300	PC3545	PC9530	PC6510	PC215K	PD2000	CN2000	CN20	CN30	H01	G10		ST30A	ST20
1000 Тип	RDHW 0501M0E							●											E12 E13
	0501M0F																		
	0501M0S																		
RDKW 0501M0E				●															
RDHW 06T1M0E							●												
06T1M0F																			
1500 Тип	06T1M0S																		
	RDKW 06T1M0E				●														

Комплектующие



Винт кассеты



Ключ

1000 Тип	FTNA0203	TW06P
1500 Тип	FTNA02205	TW06P

FMRS2000/2500



Рис. 1



Рис. 2

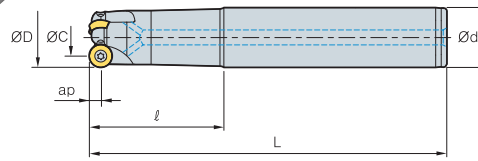

- AR : 5°
- RR : -5°~-1°

(мм)

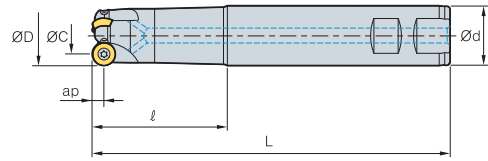
Обозначение		ØD	ØC	Ød	ℓ	L	ap		Рис.	
FMRS	2015HRD-S	2	15	8	16	55	115	3.5	0.3	2
	2015HRD-M	2	15	8	20	80	150	3.5	0.4	2
	2015HRD-L	2	15	8	20	90	200	3.5	0.5	2
	2020HRD-S	3	20	14	20	65	125	3.5	0.3	2
	2020HRD-M	3	20	14	20	80	150	3.5	0.4	2
	2020HRD-L	3	20	14	25	90	200	3.5	0.5	2
FMRS	2516HRD-S	2	16	8	16	65	125	4.0	0.3	2
	2516HRD-M	2	16	8	16	80	150	4.0	0.4	2
	2516HRD-L	2	16	8	20	90	200	4.0	0.5	2
	2520HRD-S	2	20	12	20	65	125	4.0	0.4	2
	2520HRD-M	2	20	12	20	80	150	4.0	0.5	2
	2520HRD-L	2	20	12	25	90	200	4.0	0.6	2
	2525HRD-S	3	25	17	25	55	125	4.0	0.5	2
	2525HRD-M	3	25	17	25	90	200	4.0	0.6	2
	2525HRD-L	3	25	17	32	110	250	4.0	0.7	2

Применяемые СМП

RDHW-E,F,S

RDKW



Тип	Обозначение	Тв. сплав с покрытием								Кермет			Тв. сплав				Стр.		
		NCM325	NCM335	NC5330	PC3500	PC5300	PC3545	PC9530	PC6510	PC215K	PD2000	CN2000	CN20	CN30	H01	G10		ST30A	ST20
2000 Тип	RDHW 0702M0E																		E12 E13
	0702M0F																		
	0702M0S																		
RDKW 0702M0E																			
2500 Тип	RDHW 0803M0E																		
	0803M0F																		
	0803M0S																		
RDKW 0803M0E																			

Комплектующие

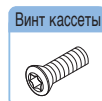

2000 Тип	FTNA02555	TW07S
2500 Тип	FTNA0305	TW09S
	FTNA0306 (Ø20 Over)	



FMRS3000



Рис. 1



Рис. 2

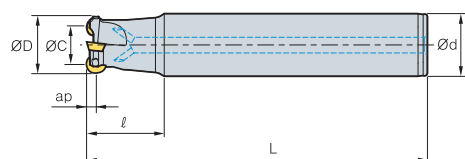

• AR : 5°
• RR : -8°~5°

(мм)

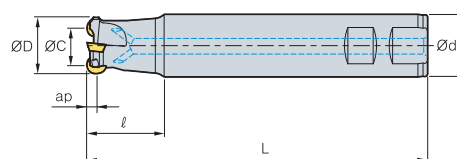
Обозначение		ØD	ØC	Ød	ℓ	L	ap		Рис.
FMRS 3021HRD-M	1	21	11	20	40	150	5	0.4	1
3021HRD-M2	2	21	11	20	40	150	5	0.4	1
3021HRD-L	1	21	11	20	50	200	5	0.6	1
3021HRD-L2	2	21	11	20	50	200	5	0.6	1
3025HRD-S	2	25	15	25	35	115	5	0.5	2
3025HRD-M	2	25	15	25	70	200	5	0.7	1
3025HRD-L	2	25	15	25	100	250	5	1	1
3026HRD-M	2	26	16	25	70	200	5	0.65	1
3026HRD-L	2	26	16	25	100	250	5	0.7	1
3032HRD-S	3	32	22	32	40	125	5	1	2
3032HRD-M	3	32	22	32	70	200	5	1.3	1
3032HRD-L	3	32	22	32	150	300	5	1.6	1
3040HRD-S	4	40	30	32	40	125	5	1.3	2
3040HRD-M	4	40	30	32	70	200	5	1.5	1
3040HRD-L	4	40	30	32	150	300	5	1.8	1

Применяемые СМП

Обозначение	RDKT-MF				RDKT-MM				RDCT-MA				Стр.				
	NCM325	NCM335	NC5330	PC3500	PC5300	PC3545	PC9530	PC6510	PC215K	PD2000	CN2000	CN20		CN30	H01	G10	ST30A
RDCT 10T3M0-MA														●			
RDKT 10T3M0-MF					●	●	●										
10T3M0-MM	●	●		●	●	●	●	●									

Комплектующие



FTGA03508(07)



TW15S

FMRS4000



Рис. 1



Рис. 2

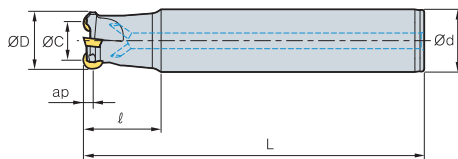

• AR : 5°
• RR : -8°~5°

(MM)

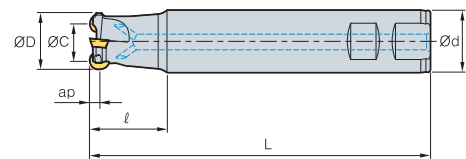
Обозначение		ØD	ØC	Ød	ℓ	L	ap		Рис.
FMRS 4032HRD-S	2	32	20	32	40	125	6	0.8	2
4032HRD-M	2	32	20	32	70	200	6	1.1	1
4032HRD-L	2	32	20	32	150	300	6	1.6	1
4033HRD-S	2	33	21	32	40	125	6	0.9	2
4033HRD-M	2	33	21	32	70	200	6	1.1	1
4033HRD-L	2	33	21	32	150	300	6	1.7	1
4040HRD-S	3	40	28	32	40	125	6	1	2
4040HRD-M	3	40	28	32	70	200	6	1.6	1
4040HRD-L	3	40	28	32	150	300	6	1.8	1
4040HRD-S40	3	40	28	40	40	125	6	1.3	2
4040HRD-M40	3	40	28	40	70	200	6	2	1
4040HRD-L40	3	40	28	40	150	300	6	2.4	1
4040HRD-S42	3	40	28	42	40	125	6	1.6	2
4040HRD-M42	3	40	28	42	70	200	6	2.4	1
4040HRD-L42	3	40	28	42	150	300	6	2.8	1
4050HRD-S	4	50	38	42	50	125	6	1.5	2
4050HRD-M	4	50	38	42	50	250	6	2.1	1
4050HRD-L	4	50	38	42	50	300	6	2.7	1
4050HRD-S40	4	50	38	40	50	150	6	2	2
4050HRD-M40	4	50	38	40	50	250	6	2.6	1
4050HRD-L40	4	50	38	40	50	300	6	3.2	1

Применяемые СМП

Обозначение	RDKT-MF									RDKT-MM				RDCT-MA				Стр.
	NCM325	NCM335	NC5330	PC3500	PC5300	PC3545	PC9530	PC6510	PC215K	PD2000	CN2000	CN20	CN30	H01	G10	ST30A	ST20	
RDCT 1204M0-MA				●	●	●	●							●				E12
RDKT 1204M0-MF				●	●	●	●											E13
1204M0-MM	●	●		●	●	●	●	●										

Комплектующие

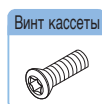

FTKA0410



TW15S



FMRS5000



Рис. 1



Рис. 2

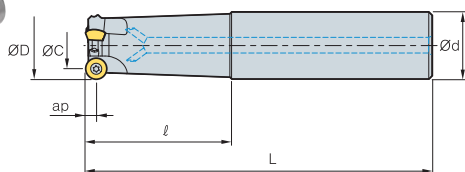

- AR : 5°
- RR : 8°~5°

(мм)

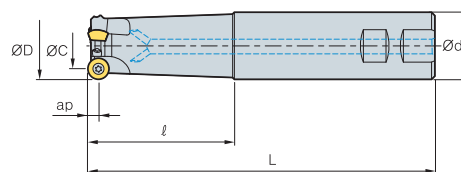
Обозначение		ØD	ØC	Ød	ℓ	L	ap		Рис.
FMRS 5040HRD-S	2	40	24	32	40	125	8	1.4	2
5040HRD-M	2	40	24	32	70	200	8	1.8	1
5040HRD-L	2	40	24	32	150	300	8	2.0	1
5040HRD-S40	2	40	24	40	40	125	8	1.6	2
5040HRD-M40	2	40	24	40	70	200	8	2.0	1
5040HRD-L40	2	40	24	40	150	300	8	2.4	1
5040HRD-S42	2	40	24	42	40	125	8	2.0	2
5040HRD-M42	2	40	24	42	70	200	8	2.4	1
5040HRD-L42	2	40	24	42	150	300	8	2.8	1
5050HRD-S40	3	50	34	40	50	150	8	2.0	2
5050HRD-M40	3	50	34	40	50	250	8	2.4	1
5050HRD-L40	3	50	34	40	50	300	8	2.6	1
5050HRD-S	3	50	34	42	50	150	8	1.5	2
5050HRD-M	3	50	34	42	50	250	8	1.8	1
5050HRD-L	3	50	34	42	50	300	8	2.0	1
5063HRD-S40	4	63	47	40	50	150	8	1.7	2
5063HRD-M40	4	63	47	40	50	250	8	2.0	1
5063HRD-L40	4	63	47	40	50	300	8	2.3	1
5063HRD-S	4	63	47	42	50	150	8	1.6	2
5063HRD-M	4	63	47	42	50	250	8	1.8	1
5063HRD-L	4	63	47	42	50	300	8	2.0	1

Применяемые СМП

RDHW-E,F,S

RDKT-MM



Обозначение	Тв. сплав с покрытием									Кермет			Тв. сплав				Стр.	
	NCM325	NCM335	NC5330	PC3500	PC5300	PC3545	PC9530	PC6510	PC215K	PD2000	CN2000	CN20	CN30	H01	G10	ST30A		ST20
RDHW 1605M0E 1605M0F 1605M0S																		E13
RDKT 1605M0-MM 1605M0-ML				●		●												

Комплектующие

Винт кассеты

Ключ



FTGA0513-P

TW20-100

FMRS6000



Рис. 1



Рис. 2

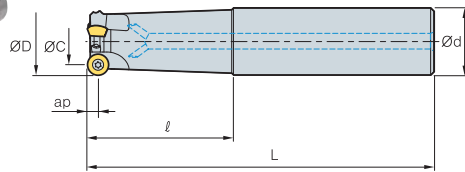

• AR : 5°
• RR : -8°~-5°

(MM)

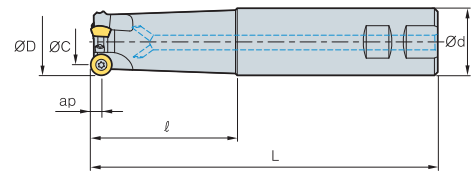
Обозначение		ØD	ØC	Ød	ℓ	L	ap		Рис.
FMRS 6050HRD-S40	3	50	31	40	50	150	10	1.3	2
6050HRD-S42	3	50	31	42	50	150	10	1.4	2
6050HRD-M40	3	50	31	40	50	250	10	2.2	1
6050HRD-M42	3	50	31	42	50	250	10	2.4	1
6050HRD-L40	3	50	31	40	50	300	10	2.7	1
6050HRD-L42	3	50	31	42	50	300	10	3.0	1
6063HRD-S40	4	63	44	40	50	150	10	1.5	2
6063HRD-S42	4	63	44	42	50	150	10	1.6	2
6063HRD-M40	4	63	44	40	50	250	10	2.5	1
6063HRD-M42	4	63	44	42	50	250	10	2.7	1
6063HRD-L40	4	63	44	40	50	300	10	3.0	1
6063HRD-L42	4	63	44	42	50	300	10	3.2	1

Применяемые СМП

RDHW-E,F,S

RDKT-MM



Обозначение	Тв. сплав с покрытием									Кермет			Тв. сплав				Стр.
	NCM225	NCM335	NC5330	PC3500	PC5300	PC3545	PC9530	PC6510	PC215K	PD2000	CN2000	CN20	CN30	H01	G10	ST30A	
RDHW 2006M0E																	
2006M0F																	
2006M0S																	
RDKT 2006M0-MM				●		●											

Комплектующие



FTGA0515-P



TW20-100



FMRM1000/1500/2000/2500

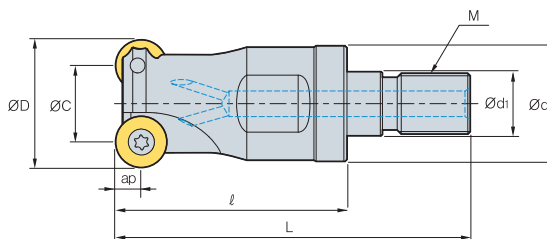

• AR : 0°~5°
• RR : -5°~ -1°

(мм)

Обозначение		ØD	ØC	Ød	Ød ₁	ℓ	L	M	ap		
FMRM	1008HRD-M06	1	8	5.5	9.5	6.5	25	40	M06	2.5	0.02
	1010HRD-M06	2	10	5	9.5	6.5	25	40	M06	2.5	0.02
	1012HRD-M06	2	12	7	11	6.5	25	40	M06	2.5	0.02
	1015HRD-M08	3	15	10	14.5	8.5	30	47	M08	2.5	0.04
FMRM	1510HRD-M06	1	10	7	9.5	6.5	25	40	M06	3.0	0.02
	1512HRD-M06	2	12	6	11	6.5	25	40	M06	3.0	0.02
	1516HRD-M08	3	16	10	14.5	8.5	30	47	M08	3.0	0.02
	1520HRD-M10	3	20	14	18	10.5	35	56	M10	3.0	0.07
FMRM	2015HRD-M08	2	15	8	14.5	8.5	30	47	M08	3.5	0.04
	2020HRD-M10	3	20	13	18	10.5	35	56	M10	3.5	0.07
FMRM	2516HRD-M08	2	16	8	14.5	8.5	30	47	M08	4.0	0.04
	2520HRD-M10	2	20	12	18	10.5	35	56	M10	4.0	0.07
	2525HRD-M12	3	25	17	22.5	12.5	45	69	M12	4.0	0.13

Применяемые СМП

RDHW-E,F,S

RDKW



Тип	Обозначение	Тв. сплав с покрытием								Кермет			Тв. сплав				Стр.	
		NCM825	NCM835	NC5330	PC3500	PC5300	PC3545	PC9530	PC6510	PC215K	PD2000	CN2000	CN20	CN30	H01	G10		ST30A
1000 Тип	RDHW 0501M0E,F,S							●										
	RDKW 0501M0E				●													
1500 Тип	RDHW 06T1M0E,F,S							●										
	RDKW 06T1M0E				●													
2000 Тип	RDHW 0702M0E.F.S							●										
	RDKW 0702M0E				●													
2500 Тип	RDHW 0803M0E,F,S							●										
	RDKW 0803M0E				●													

Применяемые оправки

Обозначение	Применяемые оправки	Обозначение	Применяемые оправки
FMRM 1008HRD-M06 1010HRD-M06 1012HRD-M06 1015HRD-M08	MAT - M06	FMRM 1520HRD-M10	MAT - M10
		FMRM 2015HRD-M08	MAT - M08
		FMRM 2020HRD-M10	MAT - M10
		FMRM 2516HRD-M08	MAT - M08
FMRM 1510HRD-M06 1512HRD-M06 1515HRD-M08	MAT - M06	2520HRD-M10	MAT - M10
		2525HRD-M12	MAT - M12

Обозначение : FMRM1008HRD-M06
Фрезерная головка с резьбой(M06)

||

Оправка : MAT-M06-020-S10S
Присоединительная резьба(M06)

Комплектующие

Винт кассеты

Ключ

Ключ



1000 Тип	FTNA0203	TW06P	-
1500 Тип	FTNA02205	TW06P	-
2000 Тип	FTNA02555	-	TW07S
2500 Тип	FTNA0305	-	TW09S

Применяемые СМП E12, E13

Применяемые оправки E233~E234

● : Наличие на складе



FMRM3000/4000/5000

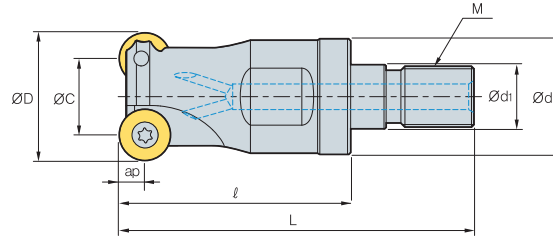

• AR : 0°~5°
• RR : -8°~5°

(mm)

Обозначение		ØD	ØC	Ød	Ød1	ℓ	L	M	ap	
FMRM 3021HRD-M10	2	21	11	18	10.5	35	56	M10	5.0	0.1
3025HRD-M12	2	25	15	22.5	12.5	45	69	M12	5.0	0.15
3032HRD-M16	3	32	22	29	17	50	77	M16	5.0	0.2
3042HRD-M16	4	42	32	29	17	50	77	M16	5.0	0.24
FMRM 4025HRD-M12	2	25	13	22.5	12.5	45	69	M12	6.0	0.12
4032HRD-M16	2	32	20	29	17	50	77	M16	6.0	0.22
4040HRD-M16	3	40	28	29	17	50	77	M16	6.0	0.23
4042HRD-M16	4	42	28	29	17	50	77	M16	6.0	0.25
FMRM 5040HRD-M16	2	40	24	29	17	50	77	M16	8.0	0.25

Применяемые СМП

		RDHW-E,F,S	RDCT-MA	RDKT-MF	RDKT-MM													
Тип	Обозначение	Тв. сплав с покрытием								Кермет			Тв. сплав				Стр.	
		NCM325	NCM335	NC5330	PC3500	PC5300	PC3545	PC5530	PC6510	PC215K	PD2000	CN2000	CN20	CN30	H01	G10		ST30A
3000 Тип	RDCT 10T3M0-MA																	
	RDKT 10T3M0-MF																	
	10T3M0-MM	●	●		●	●	●	●	●									
4000 Тип	RDCT 1204M0-MA																	
	RDKT 1204M0-MF																	
	1204M0-MM	●	●	●	●	●	●	●	●									
5000 Тип	RDHW 1605M0E,F,S																	
	RDKT 1605M0-MM																	
	1605M0-ML																	

Применяемые оправки

Обозначение	Применяемые оправки	Обозначение	Применяемые оправки
FMRM 3021HRD-M10	MAT - M10	FMRM 4025HRD-M12	MAT - M12
3025HRD-M12	MAT - M12	4032HRD-M16	
3032HRD-M16	MAT - M16	4040HRD-M16	MAT - M16
3042HRD-M16		4042HRD-M16	
		FMRM 5040HRD-M16	MAT - M16

Обозначение : FMRM1008HRD-M0006
Фрезерная головка с резьбой(M06)

II

Оправка : MAT-M06-020-S10S
Присоединительная резьба(M06)



Комплектующие

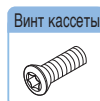

3000 Тип	FTGA03508(07)	TW15S
4000 Тип	FTKA0410	TW15S
5000 Тип	FTGA0513-P	TW20-100

Применяемые СМП E12, E13

Применяемые оправки E233~E234

● : Наличие на складе

Простота и высокая надежность системы винтового крепления СМП

HRMDouble

- Экономичность применения за счет использования двухсторонних СМП имеющих 6 режущих кромок по сравнению с фрезами серии HRM, имеющих положительную геометрию СМП с тремя режущими кромками.
- Значительный передний угол СМП способствует снижению сил резания, а стружколом - устойчивому дроблению стружки.
- Отрицательная геометрия СМП способствует повышению прочности режущей кромки и создает возможность использования второй стороны СМП
- Простота и высокая надежность системы винтового крепления СМП.
- Возможность применения высоких подач за счет специальной геометрии СМП и корпуса фрезы.
- Универсальность применения СМП для фрез правого и левого исполнения



Геометрические характеристики СМП

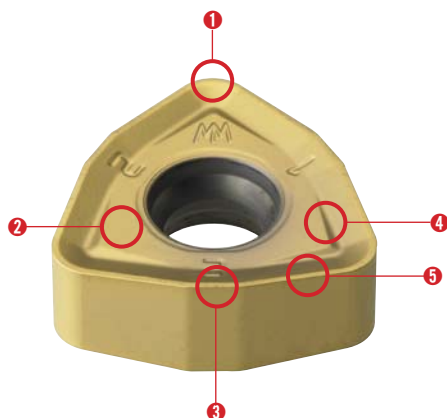

1 Радиус вершины—R

- Высокая прочность режущей кромки и вершины обеспечивает высокую стойкость при тангенциальном врезании.
- Возможность применения высокой подачи за счет специальной геометрии вершины.
- Возможность применения на фрезях, как правого, так и левого вращения.

2 Плоскость базирования

- Обеспечивает высокую точность позиционирования, защищена от трения стружки.

3 Вспомогательная режущая кромка

- Уменьшает силы резания за счет высокого переднего угла
- Обеспечивает стабильный отвод стружки
- Защищен от механических повреждений при закреплении пластины.

4 Стружколом

- Обладает симметричной геометрией допускающей
- Уменьшает силы резания за счет высокого переднего
- Уменьшает силы резания при высокой подаче.

5 Главная режущая кромка

- Обеспечивает высокое качество обработанной поверхности при высокой подаче
- Способствует снижению осевой силы резания.
- Обладает симметричной геометрией допускающей применение на фрезях, как правого, так и левого вращения.

Геометрические характеристики корпуса фрезы



СИСТЕМА ВНУТРЕННЕГО ПОДВОДА СОЖ

- Способствует улучшению отвода стружки ИЗ ЗОНЫ резания
- Повышает стойкость и снижает температуру резания

винтовое крепление СМП

- Обладает высокой надежностью и простотой.
- Не создает препятствий для отвода стружки.

СИСТЕМА базирования

- Обеспечивает высокую точность базирования по трем поверхностям.
- Обеспечивает высокую жесткость закрепления при разнонаправленных нагрузках.

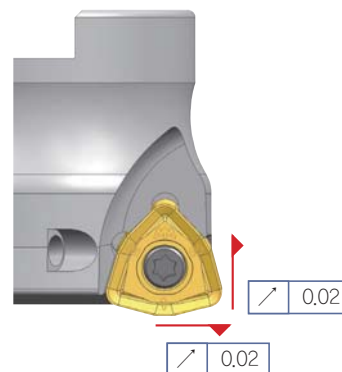

ПРИМЕЧАНИЕ : Существует много повторяющихся информации. Например : SymМетрическоеаеа дизайн для R / L Тип инструмента повторяется 4 раза на этом Стр.



Обозначение торцевой фрезы

HRM	D	C	(M)	13	063	H	R-5	
High removal Milling	Двухсторонние СМП	Тип корпуса C: Торцевая фреза	Система измерения отверстия Не обозначено: Дюймовая M: Метрическая	Диаметр вписанной окружности	Диаметр фрезы ISO: мм AISI: дюймы	Система подвода СОЖ Не обозначено: Нет H: Есть	Исполнение R: Правое L: Левое	Число зубьев 5: 5 зубьев

Обозначение концевой фрезы

HRM	D	S	09	32	H	R-2	S	32	
High removal Milling	Тип корпуса S: Концевая фреза	Диаметр фрезы 32 : Ø32	Исполнение R: Правое L: Левое	Размер фрезы S: Стандартный M: Удлиненный L: Длинный	Двухсторонние СМП	Диаметр вписанной окружности 06: тип 06 09: тип 09 13: тип 13	Система подвода СОЖ Не обозначено: Нет H: Есть	Число зубьев 2 : 2 зубьев	Диаметр хвостовика 32 : Ø32

Обозначение сменной фрезерной головки

HRM	D	M	13	35	H	R-M16	
High removal Milling	Двухсторонние СМП	Тип фрезы M: Сменная фрезерная головка	Диаметр вписанной окружности 06: тип 06 09: тип 09 13: тип 13	Диаметр фрезы ISO: мм AISI: дюймы	Система подвода СОЖ Не обозначено: Нет H: Есть	Исполнение R: Правое L: Левое	Диаметр резьбы: M16

Обозначение модульной оправки

MAT	M16	-	120	-	S32	S	-	C
High removal Milling	Диаметр резьбы: M16	Длина рабочей части 120	Диаметр хвостовика S32 : Ø32	Тип хвостовика T: Стандартный S: Усиленный	Материал оправки Не обозначено: Сталь S: Твердый сплав			



Учет радиуса при вершине (R) при создании CAM - программ

Обозначение	Режимы резания		Approx. R (мм)	
	Max.ap(мм)	Max.Sz(мм/зуб)	Input. R	Uncut
WNMX060312ZNN-MM	1.0	1.2	1.8	0.4
WNMX09T316ZNN-MM	1.5	2.0	2.5	0.6
WNMX130520ZNN-MM	2.0	3.0	3.0	0.8
WNMX160720ZNN-MM	2.5	3.5	3.5	1.2

· Информация для режиссерской части с помощью "Input.R" для CAM программы

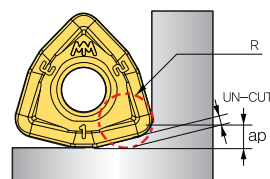

Размер необработанного сектора может зависеть от режимов резания жесткости система СПИД ит.д.

Значения безопасных зазоров между фрезой и обрабатываемой поверхностью

Обозначение	ØD(мм)	Ød(мм)	t(мм)
HRMDS0617HR-2□16	17	16	1
HRMDS0618HR-2□16	18	16	2
HRMDS0621HR-2□20	21	20	1
HRMDS0626HR-3□25	26	25	1
HRMDS0633HR-4□32	33	32	1
HRMDS0926HR-2□25	26	25	1
HRMDS0933HR-3□32	33	32	1
HRMDS0935HR-4□32	35	32	3
HRMDS0940HR-4□32	40	32	8
HRMDS0950HR-5□32	50	32	18
HRMDS0950HR-5□40	50	40	10
HRMDS0950HR-5□42	50	42	8
HRMDS1333HR-3□32	33	32	1
HRMDS1335HR-4□32	35	32	3
HRMDS1340HR-4□30	40	32	8
HRMDS1350HR-4□32	50	32	18
HRMDS1350HR-4□40	50	40	10
HRMDS1350HR-4□42	50	42	8
HRMDS1363HR-5□32	63	32	31
HRMDS1363HR-5□40	63	40	23
HRMDS1363HR-5□42	63	42	21

· Безопасный зазор предупреждает затирание корпуса инструмента об обработанную поверхность заготовки даже при больших вылетах инструмента.

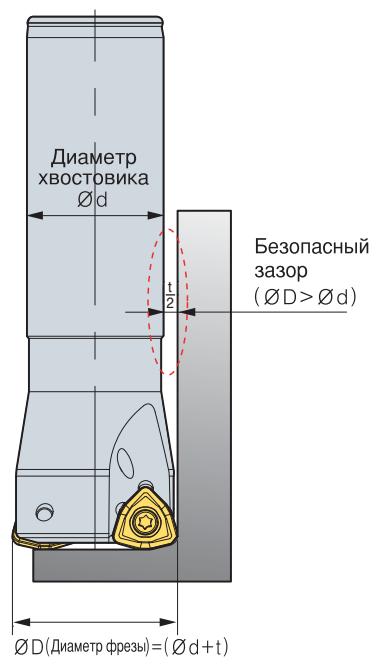

Выбор основных параметров при врезании

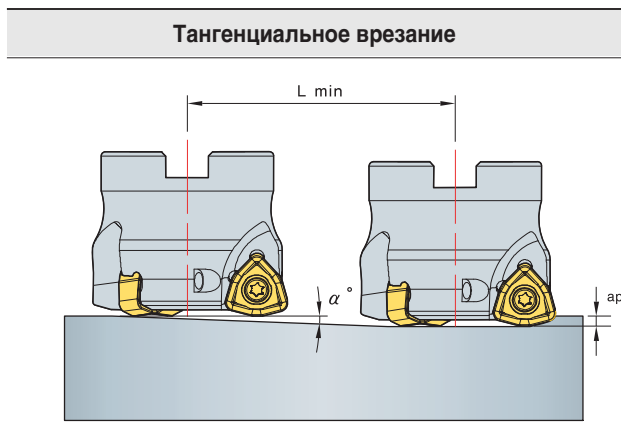

$$L_{min} = \frac{ap}{\tan \alpha^\circ} \text{ (мм)}$$

$$\varnothing D_c = \varnothing D_h - \varnothing D$$

$\varnothing D_c$ = Диаметр траектории оси фрезы

$\varnothing D_h$ = Диаметр отверстия

$\varnothing D$ = Диаметр фрезы

- При тангенциальном и радиальном врезании Подача устанавливается ниже рекомендованной на 70%.
- При радиальном врезании максимальный шаг винтовой линии не должен превышать допустимый согласно геометрическим параметрам фрезы.
- При тангенциальном врезании его геометрические параметры не должна превышать допустимый согласно геометрическим параметрам фрезы.

Обозначение	ØD Диаметр фрезы, мм	Диаметр траектории оси фрезы, мм	Тангенциальное врезание			Винтовое врезание	
			Max. ap(мм)	Максимальный угол α°	Длина врезания, мм	Min диаметр обработки, мм	Max диаметр обработки, мм
HRMDS0616HR	16	9.5	1	4.8	11	23.8	29.6
HRMDS0617HR	17	10.5	1	4.1	13	25.8	31.6
HRMDS0618HR	18	11.5	1	3.5	16	27.8	33.6
HRMDS0620HR	20	13.5	1	2.5	22	31.8	37.6
HRMDS0621HR	21	14.5	1	2.2	26	33.8	39.6
HRMDS0625HR	25	18.5	1	1.3	44	41.8	47.6
HRMDS0626HR	26	19.5	1	1.2	47	43.8	49.6
HRMDS0632HR	32	25.5	1	0.6	95	55.8	61.6
HRMDS0633HR	33	26.5	1	0.5	114	57.8	63.6
HRMDS0925HR	25	15.4	1.5	5.4	15.8	37.6	46.8
HRMDS0926HR	26	16.4	1.5	5.0	17.0	39.6	48.8
HRMDS0930HR	30	20.4	1.5	3.9	22.0	47.6	56.8
HRMDS0932HR	32	22.3	1.5	3.5	24.5	51.6	60.8
HRMDS0933HR	33	23.3	1.5	3.3	25.8	53.6	62.8
HRMDS0935HR	35	25.4	1.5	3.0	28.3	57.6	66.8
HRMDS0940HR	40	30.2	1.5	2.5	34.5	67.6	76.8
HRMDS0950HR	50	40.2	1.5	1.8	47.0	87.6	96.8
HRMDS1332HR	32	19.3	2	5.7	20.0	47	60
HRMDS1333HR	33	20.3	2	5.4	21.3	49	62
HRMDS1335HR	35	22.3	2	4.8	24.0	53	66
HRMDS1340HR	40	27.2	2	3.7	30.7	63	76
HRMDS1350HR	50	37	2	2.6	44.0	83	96
HRMDS1363HR	63	50	2	1.9	61.3	109	122
HRMDCM09040HR	40	30.2	1.5	2.5	34.5	67.6	76.8
HRMDCM09050HR	50	40.2	1.5	1.8	47.0	87.6	96.8
HRMDCM09063HR	63	53.1	1.5	1.4	63.3	113.6	122.8
HRMDC(M)09080HR	80	70.1	1.5	1.0	84.5	147.6	156.8
HRMDC(M)09100HR	100	90	1.5	0.8	109.5	187.6	196.8
HRMDCM13050HR	50	37	2	2.6	44.0	83	96
HRMDCM13063HR	63	50	2	1.9	61.3	109	122
HRMDC(M)13080HR	80	66.9	2	1.4	84.0	143	156
HRMDC(M)13100HR	100	86.9	2	1.0	110.7	183	196
HRMDC(M)13125HR	125	111.9	2	0.8	144.0	233	246
HRMDC(M)16080HR	80	63.3	2.5	1.4	102	138	156
HRMDC(M)16100HR	100	83.3	2.5	1	143	178	196
HRMDC(M)16125HR	125	108.3	2.5	0.7	204	228	246
HRMDC(M)16160R	160	143.3	2.5	0.5	286	298	316
HRMDC(M)16200R	200	183.3	2.5	0.3	477	378	396
HRMDC(M)16250R	250	233.3	2.5	0.2	716	478	496
HRMDC(M)16315R	315	298.3	2.5	0.1	1432	608	626



Область применения



Контурная обработка



Обработка плоскостей

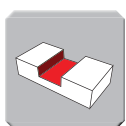

Обработка пазов



Тангенциальное врезание



Винтовое врезание



Внутренний подвод СОЖ

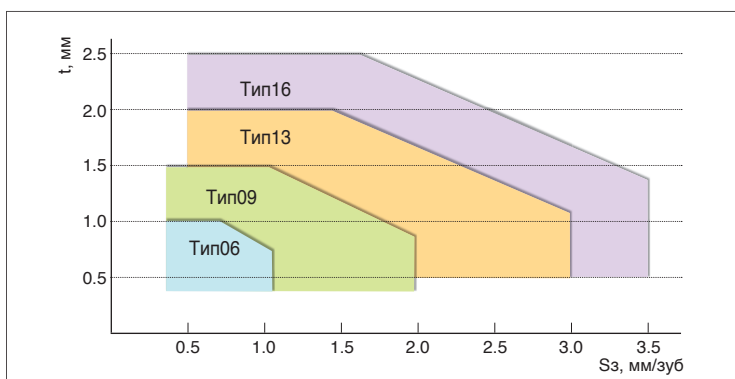

Рекомендуемые режимы резания сплава

Обрабатываемые материалы		Твердость	Марка сплава	Vp, м/мин	Sз, мм/зуб
P	Низкоуглеродистые стали	Ниже 200HB	PC3500	200	1.0 ~ 2.0
			PC3545	(100~230)	
	Среднеуглеродистые стали	Ниже 30HRC	PC3500	180	1.0 ~ 1.5
			PC3545	(100 ~ 220)	
Высокоуглеродистые легированные стали	30~40 HRC	PC3500	160	0.8 ~ 1.3	
		PC3545	(100~200)		
Закаленные стали	40~50 HRC	PC3500	120	0.6 ~ 1.2	
		PC5300	(80~180)		
M	Нержавеющие стали	Ниже 270HB	PC5300	120	0.8 ~ 1.3
PC3545	(80~150)				
K	Чугуны	Ниже 350H/mm ²	PC5300	180(100~220)	1.2 ~ 1.8

Результаты сравнительных испытаний - I



Исходные данные

Обрабатываемый материал : SM45C(HRC22)

Режимы резания : Vp=283 м/мин

Sз=1,4 мм/зуб

t=0,8 мм

V=35 мм

Охлаждение : сухое резание,

контурная обработка

Оборудование : горизонтальный МСТ

Рабочая длина фрезы : 250 мм

Обозначение инструмента:

HRMDCM13050HR-4

WNMX130520ZNN-MM(PC3500)

**Повышение
производительности: 40%
Снижение затрат
на инструмент: 80%**

* Результаты испытаний - конкурентом фрезы серии HRMD при одинаковом сечении срезаемого слоя и повышенной скорости резания позволили увеличить производительность обработки, уменьшив машинное время на 40%, при этом стойкость СМП была увеличена на 60%. Фрезы серии HRMD имеют высокую экономичность применения из-за использования СМП с 6-тью режущими кромками.

Результаты сравнительных испытаний - II



Исходные данные

Обрабатываемый материал : STS304

Режимы резания : Vp=130 м/мин

Sз=1,2 мм/зуб

t=1 мм

V=80 мм

Охлаждение : СОЖ,

Обработка пазов и фасок

Оборудование : вертикальный МСТ

Рабочая длина фрезы : 250 мм

Обозначение инструмента:

HRMDCM13050HR-4

WNMX130520ZNN-MM(PC3500)

**Повышение
производительности: 80%
Снижение затрат
на инструмент: 25%**

* Результаты испытаний - в сопоставлении HRMD с нашим конкурентом, используя тот же Режимы резания, скорость резки HRMD была выше такой же глубины резания (APxAE), время цикла было сокращено на 80%, а срок службы инструмента был таким же, но HRMD является экономически более эффективной за счет использования из 6 режущих кромок по сравнению с SDKN Тип СМП с положительными



HRMDC(M)09

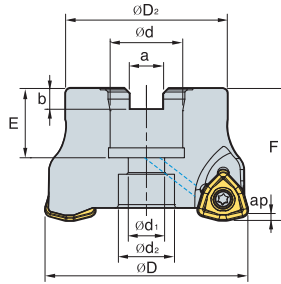

• AR : -7°
• RR : -12°~18°

													(мм)	
Обозначение		$\varnothing D$	$\varnothing D_2$	$\varnothing d$	$\varnothing d_1$	$\varnothing d_2$	a	b	E	F	ap		Крепежный винт	
HRMDCM	09040HR-3	3	40	34	16	9	14	8.4	5.6	19	40	1.5	0.2	SB0825
	09040HR-4	4	40	34	16	9	14	8.4	5.6	19	40	1.5	0.2	
	09050HR-4	4	50	42	22	11	18	10.4	6.3	21	40	1.5	0.3	
	09050HR-5	5	50	42	22	11	18	10.4	6.3	21	40	1.5	0.3	SB1025
	09063HR-5	5	63	49	22	11	18	10.4	6.3	21	40	1.5	0.5	
	09063HR-6	6	63	49	22	11	18	10.4	6.3	21	40	1.5	0.5	SB1230
	09080HR-6	6	80	57	27	14	20	12.4	7	23	50	1.5	1.1	
	09080HR-7	7	80	57	27	14	20	12.4	7	23	50	1.5	1.1	
	09100HR-7	7	100	67	32	18	26	14.4	8	25	50	1.5	1.7	SB1630
09100HR-8	8	100	67	32	18	26	14.4	8	25	50	1.5	1.7		
HRMDC	09080HR-6	6	80	57	25.4	14	20	9.5	6	24	50	1.5	1.1	SB1230
	09080HR-7	7	80	57	25.4	14	20	9.5	6	24	50	1.5	1.1	
	09080HR-31.75-6	6	80	67	31.75	18	26	12.7	8	32	63	1.5	1.5	SB1630
	09080HR-31.75-7	7	80	67	31.75	18	26	12.7	8	32	63	1.5	1.5	
	09100HR-7	7	100	67	31.75	18	26	12.7	8	32	63	1.5	2.1	SB1630
09100HR-8	8	100	67	31.75	18	26	12.7	8	32	63	1.5	2.1		

Применяемые СМП

WNMX-MM



Обозначение	Тв. сплав с покрытием									Кермет			Тв. сплав				Стр.	
	NCM325	NCM335	NC5330	PC3500	PC5300	PC5400	PC3545	PC9530	PC6510	PD2000	CN2000	CN20	CN30	H01	G10	ST30A		ST20
WNMX 09T316ZNN-MM				●	●	●	●	●										E23

Применяемые оправки

Обозначение	Оправка с хвостовиком BT	
HRMDCM	09040HR-□	BT□□-FMC16-□□
		SK□□-FMC16-□□
	09050HR-□	BT□□-FMC22-□□
	09063HR-□	SK□□-FMC22-□□
	09080HR-□	BT□□-FMC27-□□
		SK□□-FMC27-□□
09100HR-□	BT□□-FMC32-□□	
	SK□□-FMC32-□□	
HRMDC	09080HR-□	BT□□-FMA25.4-□□
		SK□□-FMA25.4-□□
	09080HR-31.75-□	BT□□-FMA31.75-□□
	09100HR-□	SK□□-FMA31.75-□□

Крепежный винт фрезы

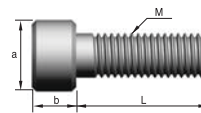

Обозначение	Геометрические размеры, мм				
	M	a	b	L	Шаг
SB0825	M08	13	8	25	1.25
SB1025	M10	16	10	25	1.5
SB1230	M12	18	12	30	1.75
SB1630	M16	24	16	30	2.0

Комплектующие

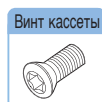

FTKA0307

TW09S



HRMDC(M)13

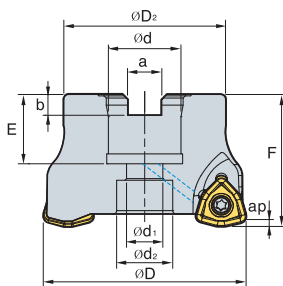

AA
14°
• AR : -7°
• RR : -12°~4°

Обозначение		ϕD	ϕD_2	ϕd	ϕd_1	ϕd_2	a	b	E	F	ap	$\frac{\rho}{\text{kg}}$	Крепежный винт
HRMDCM 13050HR-3	3	50	42	22	11	17	10.4	6.3	21	40	2	0.3	SB1025
13050HR-4	4	50	42	22	11	17	10.4	6.3	21	40	2	0.3	
13063HR-4	4	63	49	22	11	18	10.4	6.3	21	40	2	0.5	SB1025
13063HR-5	5	63	49	22	11	18	10.4	6.3	21	40	2	0.5	
13080HR-5	5	80	57	27	14	20	12.4	7	23	50	2	1	SB1230
13080HR-6	6	80	57	27	14	20	12.4	7	23	50	2	1	
13100HR-6	6	100	67	32	18	26	14.4	8	25	50	2	1.6	SB1630
13100HR-7	7	100	67	32	18	26	14.4	8	25	50	2	1.6	
13125HR-7	7	125	87	40	22	32	16.4	9	29	63	2	3.2	SB2040 MBA-M20
13125HR-8	8	125	87	40	22	32	16.4	9	29	63	2	3.2	
HRMDC 13080HR-5	5	80	57	25.4	14	20	9.5	6	24	50	2	1	SB1230
13080HR-6	6	80	57	25.4	14	20	9.5	6	24	50	2	1	
13080HR-31.75-5	5	80	67	31.75	18	26	12.7	8	32	63	2	1.4	SB1630
13080HR-31.75-6	6	80	67	31.75	18	26	12.7	8	32	63	2	1.4	
13100HR-6	6	100	67	31.75	18	26	12.7	8	32	63	2	2.1	SB1630
13100HR-7	7	100	67	31.75	18	26	12.7	8	32	63	2	2.1	
13125HR-7	7	125	87	38.1	22	32	15.9	10	35	63	2	3.3	SB2040 MBA-M20
13125HR-8	8	125	87	38.1	22	32	15.9	10	35	63	2	3.3	

Применяемые СМП

WNMX-MM



Обозначение	Тв. сплав с покрытием							Кермет			Тв. сплав				Стр.			
	NCM325	NCM335	NC5330	PC3500	PC5300	PC5400	PC3945	PC9530	PC6510	PD2000	CN2000	CN20	CN30	H01		G10	ST30A	ST20
WNMX 130520ZNN-MM				●	●	●	●	●										E23

Применяемые оправки

Обозначение	Оправка с хвостовиком BT
HRMDCM 13050HR-□	BT□□-FMC22-□□
	SK□□-FMC22-□□
13063HR-□	BT□□-FMC22-□□
13080HR-□	SK□□-FMC27-□□
13100HR-□	BT□□-FMC32-□□
	SK□□-FMC32-□□
13125HR-□	BT□□-FMC40-□□
	SK□□-FMC40-□□
HRMDC 13080HR-□	BT□□-FMA25.4-□□
	SK□□-FMA25.4-□□
13080HR-31.75-□	BT□□-FMA31.75-□□
13100HR-□	SK□□-FMA31.75-□□
	BT□□-FMA38.1-□□
13125HR-□	SK□□-FMA38.1-□□

Крепежный винт фрезы

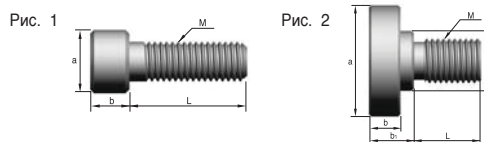

Обозначение	Геометрические размеры, мм							Рис.
	M	a	b	b1	C	L	pitch	
SB1025	M10	16	10	-	-	25	1.5	1
SB1230	M12	18	12	-	-	30	1.75	1
SB1630	M16	24	16	-	-	30	2.0	1
SB2040	M20	30	20	-	-	40	2.5	1
MBA-M20	M20	50	14	20	27	30	2.5	2

Комплектующие



ФТКА0412B

TW15S

HRMDC(M)16 *New*



Рис. 1



Рис. 2

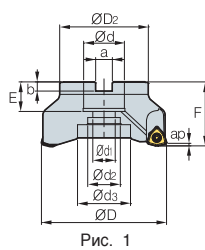

Рис. 3

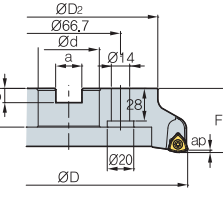

Рис. 4

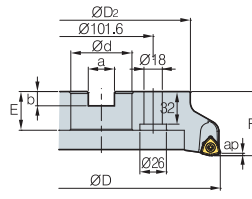

• AR : -7°
• RR : -12°~4°

Обозначение	ØD	ØD ₂	Ød	Ød ₁	Ød ₂	Ød ₃	a	b	E	F	ap	kg	Крепежный винт	Рис.	
HRMDC(M) 16080HR-4	4	80	65	25.4(27)	14	20	-	9.5(12.4)	6(7)	25(23)	50	2.5	0.99	SB1230	1
16080HR-5	5	80	65	25.4(27)	14	20	-	9.5(12.4)	6(7)	25(23)	50	2.5	0.91		
16100HR-5	5	100	85	31.75(32)	18	26	-	12.7(14.4)	8	33(25)	63(50)	2.5	1.68	SB1630	1
16100HR-6	6	100	85	31.75(32)	18	26	-	12.7(14.4)	8	33(25)	63(50)	2.5	1.64		
16125HR-6	6	125	100	38.1(40)	22	32	52	15.9(16.4)	10(9)	36(29)	63	2.5	3.23	SB2040	1
16125HR-7	7	125	100	38.1(40)	22	32	52	15.9(16.4)	10(9)	36(29)	63	2.5	3.24		
16160R-7	7	160	107	50.8(40)	-	90	-	19(16.4)	11(9)	38(32)	63	2.5	3.73	MBA-M24	2
16160R-8	8	160	107	50.8(40)	-	90	-	19(16.4)	11(9)	38(32)	63	2.5	3.77		
16200R-8	8	200	145	47.625(60)	-	132	-	25.4(25.7)	14	38	63	2.5	6.48	-	3
16200R-10	10	200	145	47.625(60)	-	132	-	25.4(25.7)	14	38	63	2.5	6.61	-	3
16250R-10	10	250	190	47.625(60)	-	190	-	25.4(25.7)	14	38	63	2.5	11.01	-	3
16250R-12	12	250	190	47.625(60)	-	190	-	25.4(25.7)	14	38	63	2.5	11.04	-	3
16315R-12	12	315	250	47.625(60)	-	238	-	25.4(25.7)	14	38	63	2.5	18.34	-	4
16315R-14	14	315	250	47.625(60)	-	238	-	25.4(25.7)	14	38	63	2.5	18.35	-	4

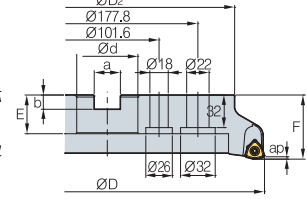
Применяемые СМП

WNMX-MM



Обозначение	Тв. сплав с покрытием								Кермет			Тв. сплав				Стр.		
	NCM325	NCM335	NC5330	PC3500	PC5300	PC5400	PC3545	PC3530	PC6510	PD2000	CN2000	CN20	CN30	H01	G10		ST30A	ST20
WNMX160720ZNN-MM					●	●												E23

Применяемые оправки

Обозначение	HRMDC	HRMDCM
HRMDC(M) 16080HR-4	BT□□-FMA25.4-□□	BT□□-FMC27-□□
16080HR-5		
16100HR-5	BT□□-FMA31.75-□□	BT□□-FMC32-□□
16100HR-6		
16125HR-6	BT□□-FMA38.1-□□	BT□□-FMB40-□□
16125HR-7		BT□□-FMC40-□□
16160R-7	BT□□-FMA50.8-□□	
16160R-8		
16200R-8		
16200R-10		
16250R-10	BT□□-FMA47.625-□□	BT□□-FMB60-□□
16250R-12		
16315R-12		
16315R-14		

Крепежный винт фрезы

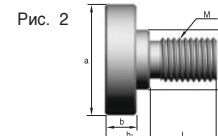
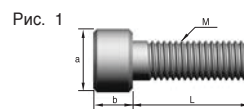

Обозначение	Геометрические размеры, мм							Рис.
	M	a	b	b1	C	L	pitch	
SB1025	M10	16	10	-	-	25	1.5	1
SB1230	M12	18	12	-	-	30	1.75	1
SB1630	M16	24	16	-	-	30	2.0	1
SB2040	M20	30	20	-	-	40	2.5	1
MBA-M20	M20	50	14	20	27	30	2.5	2
MBA-M24	M24	65	14	24	37	36	3.0	2

Комплектующие

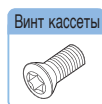

FTGA0513-P

TW20-100



HRMDS06 *New*

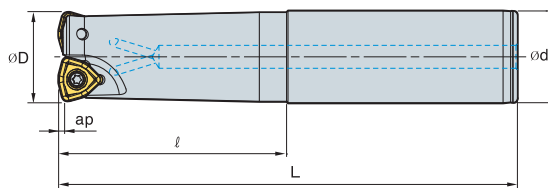

AA
14°

• AR : -7°
• RR : -17°~25°

(мм)

Обозначение		øD	ød	l	L	ap	
HRMDS 0616HR-2S16	2	16	16	30	110	1.0	0.15
0616HR-2M16	2	16	16	70	150	1.0	0.20
0616HR-2L16	2	16	16	100	200	1.0	0.26
0617HR-2S16	2	17	16	20	110	1.0	0.15
0617HR-2M16	2	17	16	20	150	1.0	0.21
0617HR-2L16	2	17	16	20	200	1.0	0.28
0618HR-2S16	2	18	16	20	110	1.0	0.15
0618HR-2M16	2	18	16	20	150	1.0	0.21
0618HR-2L16	2	18	16	20	200	1.0	0.28
0620HR-2S20	2	20	20	50	130	1.0	0.28
0620HR-2M20	2	20	20	100	180	1.0	0.38
0620HR-2L20	2	20	20	130	250	1.0	0.53
0621HR-2S20	2	21	20	20	130	1.0	0.29
0621HR-2M20	2	21	20	20	180	1.0	0.40
0621HR-2L20	2	21	20	20	250	1.0	0.57
0625HR-3S25	3	25	25	60	140	1.0	0.44
0625HR-3M25	3	25	25	80	180	1.0	0.57
0625HR-3L25	3	25	25	120	250	1.0	0.80
0626HR-3S25	3	26	25	30	140	1.0	0.46
0626HR-3M25	3	26	25	30	180	1.0	0.50
0626HR-3L25	3	26	25	30	250	1.0	0.84
0632HR-4S32	4	32	32	70	150	1.0	0.82
0632HR-4M32	4	32	32	100	200	1.0	1.10
0632HR-4L32	4	32	32	180	300	1.0	1.66
0633HR-4S32	4	33	32	40	200	1.0	1.14
0633HR-4M32	4	33	32	40	250	1.0	1.43
0633HR-4L32	4	33	32	40	300	1.0	1.73

Применяемые СМП

WNMX-MM



Обозначение	Тв. сплав с покрытием							Кермет			Тв. сплав				Стр.			
	NCM325	NCM335	NC5330	PC3500	PC5300	PC5400	PC3545	PC9530	PC6510	PD2000	CN2000	CN20	CN30	H01		G10	ST30A	ST20
WNMX 060312ZNN-MM					●	●												E23

Комплектующие



ETNA02506

TW07S

HRMDS09

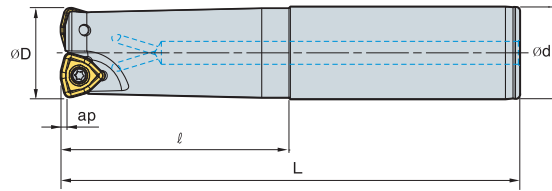

Обозначение			$\varnothing D$	$\varnothing d$	ℓ	L	ap	
HRMDS	0925HR-2S25	2	25	25	60	140	1.5	0.5
	0925HR-2M25	2	25	25	120	200	1.5	0.6
	0925HR-2L25	2	25	25	180	300	1.5	1
	0926HR-2S25	2	26	25	60	140	1.5	0.5
	0926HR-2M25	2	26	25	60	200	1.5	0.7
	0926HR-2L25	2	26	25	60	300	1.5	1
	0930HR-3S32	3	30	32	70	150	1.5	0.8
	0930HR-3M32	3	30	32	120	200	1.5	1
	0930HR-3L32	3	30	32	180	300	1.5	1.5
	0932HR-3S32	3	32	32	70	150	1.5	0.8
	0932HR-3M32	3	32	32	120	200	1.5	1.1
	0932HR-3L32	3	32	32	180	300	1.5	1.7
	0933HR-3S32	3	33	32	70	150	1.5	0.8
	0933HR-3M32	3	33	32	70	200	1.5	1.1
	0933HR-3L32	3	33	32	70	300	1.5	1.7
	0935HR-4S32	4	35	32	50	150	1.5	0.9
	0935HR-4M32	4	35	32	50	200	1.5	1.1
	0935HR-4L32	4	35	32	50	300	1.5	1.7
	0940HR-4S32	4	40	32	50	150	1.5	0.9
	0940HR-4M32	4	40	32	50	250	1.5	1.5
0940HR-4L32	4	40	32	50	300	1.5	1.8	
0940HR-4S40	4	40	40	60	150	1.5	1.3	

Применяемые СМП

WNMX-MM



Обозначение	Тв. сплав с покрытием									Кермет			Тв. сплав				Стр.	
	NCM325	NCM335	NC5330	PC3500	PC5300	PC5400	PC3545	PC9530	PC6510	PD2000	CN2000	CN20	CN30	H01	G10	ST30A		ST20
WNMX 09T316ZNN-MM				●	●	●	●	●										E23

Комплектующие



FTKA0307

TW09S



HRMDS09

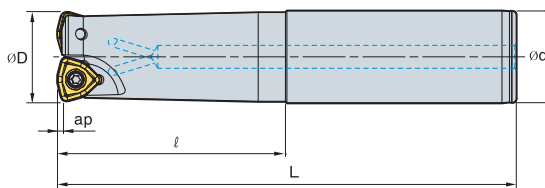

(мм)

Обозначение		øD	ød	ℓ	L	ap	
HRMDS 0940HR-4M40	4	40	40	130	250	1.5	2.2
0940HR-4L40	4	40	40	180	300	1.5	2.7
0940HR-4S42	4	40	42	60	150	1.5	1.4
0940HR-4M42	4	40	42	130	250	1.5	2.3
0940HR-4L42	4	40	42	180	300	1.5	2.8
0950HR-4S32	4	50	32	40	150	1.5	1.1
0950HR-4M32	4	50	32	40	250	1.5	1.6
0950HR-4L32	4	50	32	40	300	1.5	2
0950HR-4S40	4	50	40	40	150	1.5	1.4
0950HR-4M40	4	50	40	40	250	1.5	2.4
0950HR-4L40	4	50	40	40	300	1.5	2.9
0950HR-4S42	4	50	42	40	150	1.5	1.6
0950HR-4M42	4	50	42	40	250	1.5	2.6
0950HR-4L42	4	50	42	40	300	1.5	3.1
0950HR-5S32	5	50	32	40	150	1.5	1.1
0950HR-5M32	5	50	32	40	250	1.5	1.6
0950HR-5L32	5	50	32	40	300	1.5	2
0950HR-5S40	5	50	40	40	150	1.5	1.4
0950HR-5M40	5	50	40	40	250	1.5	2.4
0950HR-5L40	5	50	40	40	300	1.5	2.9
0950HR-5S42	5	50	42	40	150	1.5	1.6
0950HR-5M42	5	50	42	40	250	1.5	2.6
0950HR-5L42	5	50	42	40	300	1.5	3.1

Применяемые СМП

WNMX-MM



Обозначение	Тв. сплав с покрытием								Кермет			Тв. сплав				Стр.		
	NCM325	NCM335	NC5330	PC35100	PC53100	PC54100	PC3545	PC9530	PC6510	PD2000	CN2000	CN20	CN60	H01	G10		ST30A	ST20
WNMX 09T316ZNN-MM				●	●	●	●	●										E23

Комплектующие



FTKA0307

TW09S

HRMDS13

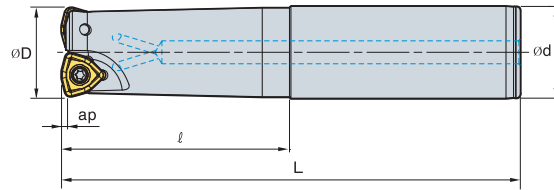

AA
14°
• AR : -7°
• RR : -14°~16°

(MM)

Обозначение		øD	ød	ℓ	L	ap	
HRMDS 1332HR-2S32	2	32	32	70	150	2	0.8
1332HR-2M32	2	32	32	120	200	2	1
1332HR-2L32	2	32	32	180	300	2	1.6
1333HR-2S32	2	33	32	70	150	2	0.8
1333HR-2M32	2	33	32	70	200	2	1.1
1333HR-2L32	2	33	32	70	300	2	1.7
1335HR-2S32	2	35	32	50	150	2	0.8
1335HR-2M32	2	35	32	50	200	2	1.1
1335HR-2L32	2	35	32	50	300	2	1.7
1340HR-3S32	3	40	32	50	150	2	0.8
1340HR-3M32	3	40	32	50	250	2	1.4
1340HR-3L32	3	40	32	50	300	2	1.7
1340HR-3S40	3	40	40	60	150	2	1.2
1340HR-3M40	3	40	40	130	250	2	2.1
1340HR-3L40	3	40	40	180	300	2	2.6
1340HR-3S42	3	40	42	60	150	2	1.4
1340HR-3M42	3	40	42	130	250	2	2.3
1340HR-3L42	3	40	42	180	300	2	2.7
1350HR-3S32	3	50	32	50	150	2	1.1
1350HR-3M32	3	50	32	50	250	2	1.7
1350HR-3L32	3	50	32	50	300	2	2
1350HR-3S40	3	50	40	50	150	2	1.5
1350HR-3M40	3	50	40	50	250	2	2.4
1350HR-3L40	3	50	40	50	300	2	2.9
1350HR-3S42	3	50	42	50	150	2	1.6
1350HR-3M42	3	50	42	50	250	2	2.6
1350HR-3L42	3	50	42	50	300	2	3.1

Применяемые СМП

WNMX-MM



Обозначение	Тв. сплав с покрытием										Кермет			Тв. сплав				Стр.
	NCM325	NCM335	NC5330	PC3500	PC3300	PC5400	PC3545	PC9530	PC6510	PD2000	CN2000	CN20	CN30	H01	G10	ST30A	ST20	
WNMX 130520ZNN-MM				●	●	●	●	●									E23	

Комплектующие



ФТКА0412B

TW15S



HRMDS13

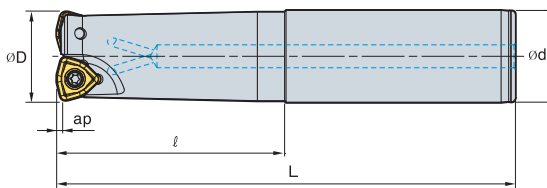

• AR : -7°
• RR : -14°~-16°

(мм)

Обозначение		øD	ød	l	L	ap	
HRMDS 1350HR-4S32	4	50	32	50	150	2	1.1
1350HR-4M32	4	50	32	50	250	2	1.7
1350HR-4L32	4	50	32	50	300	2	2
1350HR-4S40	4	50	40	50	150	2	1.5
1350HR-4M40	4	50	40	50	250	2	2.4
1350HR-4L40	4	50	40	50	300	2	2.9
1350HR-4S42	4	50	42	50	150	2	1.6
1350HR-4M42	4	50	42	50	250	2	2.6
1350HR-4L42	4	50	42	50	300	2	3.1
1363HR-4S32	4	63	32	50	150	2	1.4
1363HR-4M32	4	63	32	50	250	2	2.1
1363HR-4L32	4	63	32	50	300	2	2.4
1363HR-4S40	4	63	40	50	150	2	1.8
1363HR-4M40	4	63	40	50	250	2	2.8
1363HR-4L40	4	63	40	50	300	2	3.2
1363HR-4S42	4	63	42	50	150	2	1.9
1363HR-4M42	4	63	42	50	250	2	3
1363HR-4L42	4	63	42	50	300	2	3.5
1363HR-5S32	5	63	32	50	150	2	1.5
1363HR-5M32	5	63	32	50	250	2	2
1363HR-5L32	5	63	32	50	300	2	2.3
1363HR-5S40	5	63	40	50	150	2	1.8
1363HR-5M40	5	63	40	50	250	2	2.8
1363HR-5L40	5	63	40	50	300	2	3.2
1363HR-5S42	5	63	42	50	150	2	1.9
1363HR-5M42	5	63	42	50	250	2	3
1363HR-5L42	5	63	42	50	300	2	3.5

Применяемые СМП

WNMX-MM



Обозначение	Тв. сплав с покрытием								Кермет			Тв. сплав				Стр.		
	NCM325	NCM335	NC5330	PC3500	PC5300	PC5400	PC3545	PC9530	PC6510	PD2000	CN2000	CN20	CN30	H01	G10		ST30A	ST20
WNMX 130520ZNN-MM				●	●	●	●	●										E23

Комплектующие



FTKA0412B

TW15S

HRMDM 06 *New*

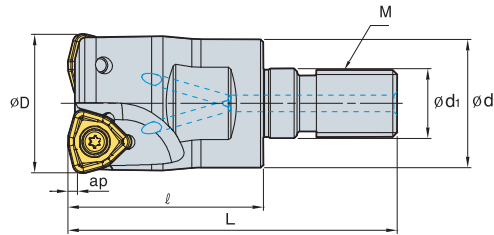
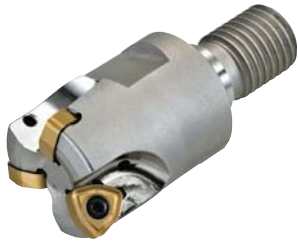

(MM)

Обозначение		$\varnothing D$	$\varnothing d$	$\varnothing d_1$	ℓ	L	M	ap	
HRMDM 0616HR-M08	2	16	14.5	8.5	25	42	M08	1.0	0.03
0617HR-M08	2	17	14.5	8.5	25	42	M08	1.0	0.03
0618HR-M08	2	18	14.5	8.5	25	42	M08	1.0	0.03
0620HR-M10	2	20	18	10.5	30	51	M10	1.0	0.06
0621HR-M10	2	21	18	10.5	30	51	M10	1.0	0.07
0625HR-M12	3	25	23	12.5	35	59	M12	1.0	0.10
0626HR-M12	3	26	23	12.5	35	59	M12	1.0	0.11
0632HR-M16	4	32	29	17	40	67	M16	1.0	0.21
0633HR-M16	4	33	29	17	40	67	M16	1.0	0.22

Применяемые СМП

WNMX-MM



Обозначение	Тв. сплав с покрытием									Кермет			Тв. сплав				Стр.	
	NCM325	NCM335	NC5330	PC3500	PC5300	PC5400	PC3545	PC3530	PC6510	PD2000	CN2000	CN20	CN30	H01	G10	ST30A		ST20
WNMX060312ZNN-MM					●	●												E23

Применяемые оправки

Обозначение	Применяемые оправки	Обозначение	Применяемые оправки
HRMDM 0616HR-M08	MAT- M08	HRMDM 0625HR-M12 0626HR-M12 0632HR-M16 0633HR-M16	MAT- M12
0617HR-M08	MAT- M08		MAT- M12
0618HR-M08	MAT- M08		MAT- M16
0620HR-M10	MAT- M10		MAT- M16
0621HR-M10	MAT- M10		MAT- M16

Обозначение : HRMDM0932HR-M16
Фрезерная головка с резьбой(M16)

||

Оправка : MAT-M16-035-S32S
Присоединительная резьба(M16)

Комплектующие



ETNA02506

TW07S

HRMDM09/13

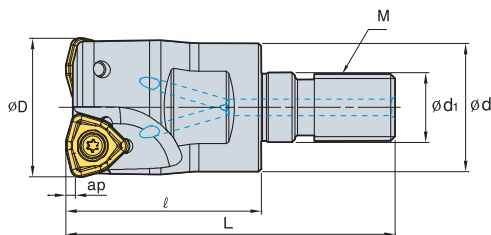
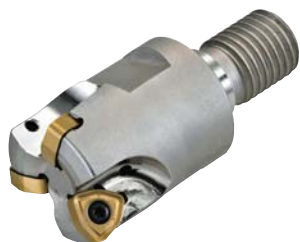

AA
14°

• AR : -7°

• RR : -18°~25°

(MM)

Обозначение		$\varnothing D$	$\varnothing d$	$\varnothing d_1$	ℓ	L	M	ap	
HRMDM	0925HR-M12	2	25	23	12.5	35	M12	1.5	0.10
	0926HR-M12	2	26	23	12.5	35	M12	1.5	0.11
	0930HR-M16	3	30	29	17	40	M16	1.5	0.19
	0932HR-M16	3	32	29	17	40	M16	1.5	0.20
	0933HR-M16	3	33	29	17	40	M16	1.5	0.21
	0935HR-M16	4	35	29	17	40	M16	1.5	0.22
	0940HR-M16	4	40	29	17	40	M16	1.5	0.25
HRMDM	1332HR-M16	2	32	29	17	40	M16	2	0.20
	1333HR-M16	2	33	29	17	40	M16	2	0.20
	1335HR-M16	2	35	29	17	40	M16	2	0.22
	1340HR-M16	3	40	29	17	45	M16	2	0.26

Применяемые СМП

WNNX-MM



Тип	Обозначение	Тв. сплав с покрытием							Кермет			Тв. сплав				Стр.			
		NCM325	NCM335	NC5330	PC3500	PC5300	PC5400	PC3545	PC8530	PC6510	PD2000	CN2000	CN20	CN30	H01		G10	ST30A	ST20
09 Тип	WNNX09T316ZNN-MM			●	●	●	●	●											E23
13 Тип	WNNX130520ZNN-MM			●	●	●	●	●											

Применяемые оправки

Обозначение	Применяемые оправки	Обозначение	Применяемые оправки
HRMDM	0925HR-M12	HRMDM 0940HR-M16 1332HR-M16 1333HR-M16 1335HR-M16 1340HR-M16	MAT- M12
	0926HR-M12		
	0930HR-M16		
	0932HR-M16		
	0933HR-M16		
	0935HR-M16		
	0935HR-M16		

Обозначение : HRMDM0932HR-M16
Фрезерная головка с резьбой(M16)

||

Оправка : MAT-M16-035-S32S
Присоединительная резьба(M16)

Комплектующие



Винт кассеты



Ключ

09 Тип	FTKA0307	TW09S
13 Тип	FTKA0412B	TW15S

Применяемые СМП E23

Применяемые оправки E233~E234

● : Наличие на складе

HRMC(M) 13/15

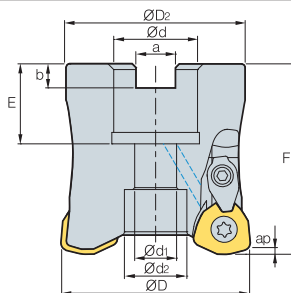

													(mm)	
Обозначение		ØD	ØD ₂	Ød	Ød ₁	Ød ₂	a	b	E	F	ap		Крепежный винт	
HRMC(M)	13050HR-3	3	50	47	22.225(22)	11	16.4	8.0(10.4)	5(6.3)	20(21)	50	2.0	0.4	SB1035
	13050HR-4	4	50	47	22.225(22)	11	16.4	8.0(10.4)	5(6.3)	20(21)	50	2.0	0.4	SB1035
	13063HR-4	4	63	60	22.225(22)	11	17	8.0(10.4)	5(6.3)	20(21)	50	2.0	0.7	SB1035
	13080HR-5	5	80	76	31.75(27)	18(13)	26(20)	12.7(12.4)	8(7)	32(23)	70	2.0	1.6	SB16(12)45
HRMC(M)	15063HR-3	3	63	60	22.225(22)	11	17	8.0(10.4)	5(6.3)	20(21)	50	2.5	0.7	SB1035
	15080HR-4	4	80	76	31.75(27)	18(13)	26(20)	12.7(12.4)	8(7)	32(23)	70	2.5	1.7	SB16(12)45
	15100HR-5	5	100	96	31.75(32)	18	26	12.7(14.4)	8(8)	32(26)	70	2.5	2.8	SB1645
	15100HR-6	6	100	96	31.75(32)	18	26	12.7(14.4)	8(8)	32(26)	70	2.5	3.2	SB1645
	15125HR-6	6	125	98	38.1(40)	22	32	15.9(16.4)	10(9)	35(29)	63	2.5	3.3	SB2040
	15160R-7	7	160	100	50.8(40)	-	72	19.0(16.4)	11(9)	38(35)	63	2.5	4.3	MBA-M24(M20)

Примечание: отверстие для подвода СОЖ Ø50~Ø125

() Метрическая система

Применяемые СМП

WDKT-MH



Тип	Обозначение	Тв. сплав с покрытием								Кермет			Тв. сплав				Стр.	
		NCM225	NCM335	NC330	PC3500	PC3300	PC3400	PC3545	PC9530	PC6510	PD2000	CN2000	CN20	CN30	H01	G10		ST30A
13 Тип	WDKT130520ZDSR-MH				●	●	●	●	●									
15 Тип	WDKT150625ZDSR-MH				●	●	●	●	●									

Применяемые оправки

Обозначение	Применяемые оправки	
	HRMC	HRMCM
HRMC(M) 13050HR-3	BT□□-FMA22.225-□□	BT□□-FMC22-□□
	SK□□-FMA22.225-□□	SK□□-FMC22-□□
	SK□□-FMA22.225-□□	SK□□-FMC22-□□
13063HR-4	BT□□-FMA31.75-□□	BT□□-FMC27-□□
	SK□□-FMA31.75-□□	SK□□-FMC27-□□
13080HR-5	BT□□-FMA22.225-□□	BT□□-FMC27-□□
15063HR-3	BT□□-FMA22.225-□□	BT□□-FMC22-□□
	SK□□-FMA22.225-□□	SK□□-FMC22-□□
15080HR-4	BT□□-FMA31.75-□□	BT□□-FMC27-□□
	SK□□-FMA31.75-□□	SK□□-FMC27-□□
15100HR-5	BT□□-FMA31.75-□□	BT□□-FMC32-□□
15100HR-6	SK□□-FMA31.75-□□	SK□□-FMC32-□□
15125HR-6	BT□□-FMA38.1-□□	BT□□-FMB40-□□
	SK□□-FMA38.1-□□	SK□□-FMC40-□□
15160R-7	BT□□-FMA50.8-□□	SK□□-FMC40-□□

Крепежный винт фрезы

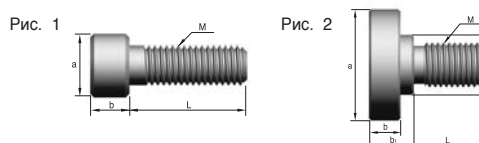

Обозначение	Геометрические размеры, мм							Рис.
	M	a	b	b1	C	L	pitch	
SB1035	M10	16	10	-	-	35	1.5	1
SB1245	M12	18	12	-	-	45	1.75	1
SB1645	M16	24	16	-	-	45	2.0	1
SB2040	M20	30	20	-	-	40	2.5	1
MBA-M20	M20	50	14	20	27	30	2.5	2
MBA-M24	M24	65	14	24	37	36	3.0	2

Комплектующие



13 Тип (Ø50,63,80)	FTGA0513-P	CHH4.5R1	CTX04513H	CR03	TW20-100
15 Тип (Ø63,80,100,125, 160)	FTGA0513-P	CHH5.5R1	CTX0515	CR04	TW20-100

Применяемые СМП E23

Присоединительные размеры смотреть на стр. E270~E272

● : Наличие на складе

HRMS 08/10

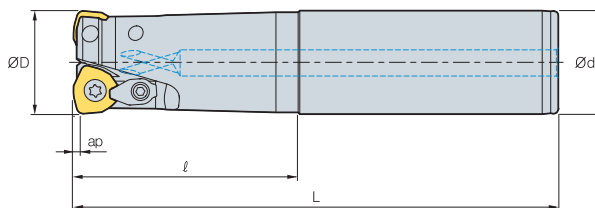

(mm)

Обозначение		$\varnothing D$	$\varnothing d$	ℓ	L	aD	
HRMS	0820HR-2S20	2	20	20	50	130	0.3
	0820HR-2M20	2	20	20	100	180	0.4
	0820HR-2L20	2	20	20	130	250	0.5
	0821HR-2S20	2	21	20	50	130	0.3
	0821HR-2M20	2	21	20	50	180	0.4
	0821HR-2L20	2	21	20	50	250	0.5
HRMS	1025HR-2S25	2	25	25	60	140	0.4
	1025HR-2M25	2	25	25	120	200	0.6
	1025HR-2L25	2	25	25	180	300	0.9
	1026HR-2S25	2	26	25	60	140	0.4
	1026HR-2M25	2	26	25	60	200	0.6
	1026HR-2L25	2	26	25	60	300	1.0
	1030HR-2S32	2	30	32	70	150	0.8
	1030HR-2M32	2	30	32	120	200	1.0
1030HR-2L32	2	30	32	180	300	1.5	

Применяемые СМП

WDKT-MH



Тип	Обозначение	Тв. сплав с покрытием								Кермет			Тв. сплав				Стр.	
		NCM325	NCM335	NC5330	PC3500	PC5300	PC5400	PC3545	PC9530	PC6510	PD2000	CN2000	CN20	CN30	H01	G10		ST30A
08 Тип	WDKT080316ZDSR-MH				●	●	●	●	●									
10 Тип	WDKT10T320ZDSR-MH				●	●	●	●	●									

Комплектующие



08 Тип	FTNA0306	-	-	-	TW09P
10 Тип	FTKA0408	CHN3.5R1	CTX03510	CR03	TW15S

HRMS 13

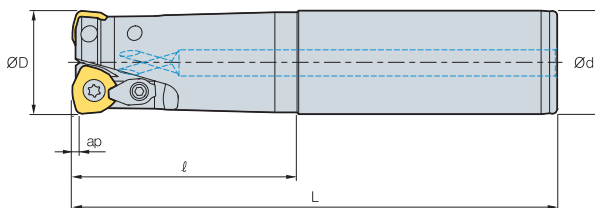

Обозначение			ØD	ød	l	L	ap	
HRMS	1332HR-2S32	2	32	32	70	150	2.0	0.8
	1332HR-2M32	2	32	32	120	200	2.0	1.0
	1332HR-2L32	2	32	32	180	300	2.0	1.6
	1333HR-2S32	2	33	32	70	150	2.0	0.8
	1333HR-2M32	2	33	32	70	200	2.0	1.1
	1333HR-2L32	2	33	32	70	300	2.0	1.7
	1335HR-2S32	2	35	32	50	150	2.0	0.8
	1335HR-2M32	2	35	32	50	200	2.0	1.1
	1335HR-2L32	2	35	32	50	300	2.0	1.7
	1340HR-3S32	3	40	32	50	150	2.0	0.8
	1340HR-3M32	3	40	32	50	250	2.0	1.4
	1340HR-3L32	3	40	32	50	300	2.0	1.7
	1340HR-3S40	3	40	40	60	150	2.0	1.2
	1340HR-3M40	3	40	40	130	250	2.0	2.1
	1340HR-3L40	3	40	40	180	300	2.0	2.6
	1340HR-3S42	3	40	42	60	150	2.0	1.4
	1340HR-3M42	3	40	42	130	250	2.0	2.3
	1340HR-3L42	3	40	42	180	300	2.0	2.7

Применяемые СМП

WDKT-MH



Обозначение	Тв. сплав с покрытием								Кермет			Тв. сплав				Стр.		
	NCM325	NCM335	NC5330	PC3500	PC5300	PC5400	PC3545	PC3530	PC6510	PD2000	CN2000	CN20	CN30	H01	G10		ST30A	ST20
WDKT130520ZDSR-MH				●	●	●	●	●										E23

Комплектующие



Ø32,33,35	FTGA0510-P	CHH4.5R1	CTX04513H	CR03	TW20
Ø40	FTGA0512-P	CHH5.5R1	CTX04513H	CR03	TW20



HRMS 15

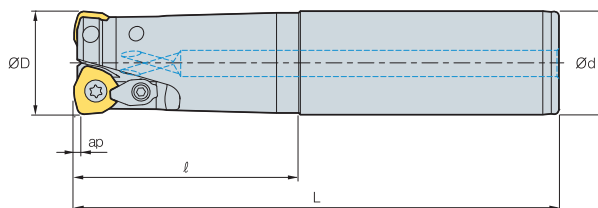

Обозначение		ØD	Ød	ℓ	L	ap		(MM)
HRMS 1550HR-3S32	3	50	32	50	150	2.5	1.0	
1550HR-3M32	3	50	32	50	250	2.5	1.6	
1550HR-3L32	3	50	32	50	300	2.5	1.9	
1550HR-3S40	3	50	40	50	150	2.5	1.4	
1550HR-3M40	3	50	40	50	250	2.5	2.3	
1550HR-3L40	3	50	40	50	300	2.5	2.8	
1550HR-3S42	3	50	42	50	150	2.5	1.5	
1550HR-3M42	3	50	42	50	250	2.5	2.5	
1550HR-3L42	3	50	42	50	300	2.5	3.0	
1563HR-4S32	4	63	32	50	150	2.5	1.3	
1563HR-4M32	4	63	32	50	250	2.5	1.9	
1563HR-4L32	4	63	32	50	300	2.5	2.2	
1563HR-4S40	4	63	40	50	150	2.5	1.7	
1563HR-4M40	4	63	40	50	250	2.5	2.6	
1563HR-4L40	4	63	40	50	300	2.5	3.1	
1563HR-4S42	4	63	42	50	150	2.5	1.8	
1563HR-4M42	4	63	42	50	250	2.5	2.8	
1563HR-4L42	4	63	42	50	300	2.5	3.3	

Применяемые СМП

WDKT-MH



Обозначение	Тв. сплав с покрытием								Кермет			Тв. сплав				Стр.	
	NCM825	NCM835	NC6330	PC3500	PC6300	PC5400	PC3545	PC9530	PC6510	PD2000	CN2000	CN20	CN30	H01	G10		ST30A
WDKT 150625ZDSR-MH				●	●	●	●	●									
																	E23

Комплектующие

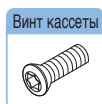

FTGA0513-P CHH5.5R1 CTX0515 CR04 TW20

HRMM08/10/13

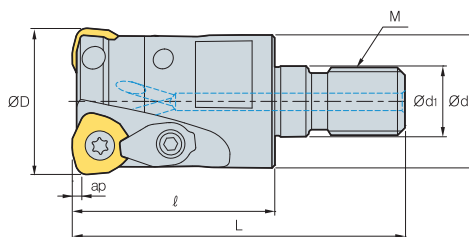

(mm)

Обозначение		$\varnothing D$	$\varnothing d$	$\varnothing d_1$	l	L	M	ap	
HRMM 0820HR-M10	2	20	18	10.5	30	51	M10	1	0.06
0821HR-M10	2	21	18	10.5	30	51	M10	1	0.06
0825HR-M12	3	25	23	12.5	35	59	M12	1	0.11
0826HR-M12	3	26	23	12.5	35	59	M12	1	0.11
0828HR-M12	3	28	23	12.5	35	59	M12	1	0.12
0832HR-M16	4	32	29	17	40	67	M16	1	0.21
0833HR-M16	4	33	29	17	40	67	M16	1	0.21
0835HR-M16	4	35	29	17	40	67	M16	1	0.23
0840HR-M16	5	40	29	17	40	67	M16	1	0.25
HRMM 1025HR-M12	2	25	23	12.5	35	59	M12	1.5	0.1
1026HR-M12	2	26	23	12.5	35	59	M12	1.5	0.1
1030HR-M16	2	30	29	17	40	67	M16	1.5	0.2
1032HR-M16	3	32	29	17	45	72	M16	1.5	0.26
1035HR-M16	3	35	29	17	45	72	M16	1.5	0.23
1040HR-M16	4	40	29	17	45	72	M16	1.5	0.27
HRMM 1332HR-M16	2	32	29	17	40	67	M16	2	0.17
1333HR-M16	2	33	29	17	40	67	M16	2	0.17
1335HR-M16	2	35	29	17	40	67	M16	2	0.19
1340HR-M16	3	40	29	17	45	72	M16	2	0.24

Применяемые СМП

WDKT-MH



Тип	Обозначение	Тв. сплав с покрытием							Кермет			Тв. сплав				Стр.		
		NCM325	NCM335	NC5330	PC3500	PC3300	PC5400	PC3545	PC3630	PC6510	PD2000	CN2000	CN20	CN30	H01		G10	ST30A
08 Тип	WDKT080316ZDSR-MH				●	●	●	●										
10 Тип	WDKT10T320ZDSR-MH				●	●	●	●										
13 Тип	WDKT130520ZDSR-MH				●	●	●	●										

Применяемые оправки

Обозначение	Оправки	Обозначение	Оправки	Обозначение	Оправки
HRMM 0820HR-M10	MAT-M10	HRMM 0835HR-M16	MAT-M16	HRMM 1040HR-M16	MAT-M16
0821HR-M10		0840HR-M16		HRMM 1332HR-M16	
0825HR-M12	MAT-M12	HRMM 1025HR-M12	MAT-M12	1333HR-M16	MAT-M16
0826HR-M12		1026HR-M12		1335HR-M16	
0828HR-M12		1030HR-M16		1340HR-M16	
0832HR-M16		1032HR-M16			
0833HR-M16	MAT-M16	1035HR-M16			

Обозначение : HRMM0820HR-M10
Фрезерная головка с резьбой(M16)

II

Оправка : MAT-M10-030-S20S
Присоединительная резьба(M16)

Комплектующие

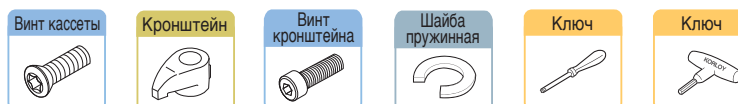

08 Тип		FTNA0306	-	-	-	-
10 Тип		FTKA0408	CHH3.5R1	CTX03510	CR03	TW15S
13 Тип	$\varnothing 32,33,35$	FTGA0510-P	CHH4.5R1	CTX04513H	CR03	TW20
	$\varnothing 40$	FTGA0512-P	CHH5.5R1	CTX04513H	CR03	TW20



THE

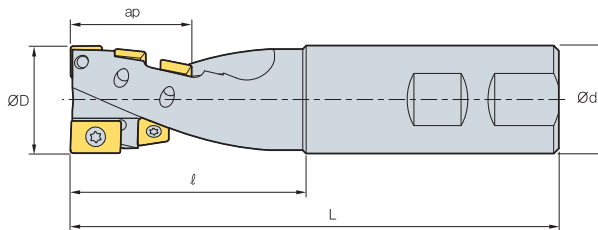

AA
90°
• AR : 5°, 10°
• RR : -5°

Обозначение	ØD	ød	ℓ	L	ap	Количество зубьев	kg	Применяемые СМП	
								Торцевые СМП	Переферийные СМП
THE 25R	25	25	55	120	25	2	0.4	APLT070304R 1z	SPMT060304 4z
32R	32	32	70	145	40	2	0.5	ADLT150308R 1z	SDMT090308-MM 5z
40R	40	42	88	175	54	2	1.3	ZPMT1504PPSR-MM 1z	SPMT120408-MM 5z
50R	50	42	85	175	54	4	1.4	ZPMT1504PPSR-MM 2z	SPMT120408-MM 10z

Применяемые СМП

	ADLT	APLT	SPMT-MM	SPMT	SDMT-MM	ZPMT-MM												
Обозначение	Тв. сплав с покрытием								Кермет			Тв. сплав				Стр.		
	NCM325	NCM335	NC5330	PC3500	PC5300	PC3545	PC9530	PC8510	PC215K	PD2000	CN2000	CN20	CN80	H01	G10		ST30A	ST20
SPMT060304	●																	E04
SDMT090308-MM				●														E05
SPMT120408-MM				●		●												E14
APLT070304R																		E21
ADLT150308R	●																	E24
ZPMT1504PPSR-MM				●		●												

Рекомендации по выбору режимов резания и марки сплава

• Обработка пазов				• Обработка уступов			
Обрабатываемые материалы	Режимы резания		Марка сплава	Обрабатываемые материалы	Режимы резания		Марка сплава
	V(м/мин)	Sz(мм/зуб)			V(м/мин)	Sz(мм/зуб)	
P	60~120	0.06~0.20	NCM325	P	100~180	0.10~0.35	NCM325
M	50~120	0.06~0.15	NCM325	M	80~180	0.10~0.30	NCM325
K	60~120	0.10~0.20	NCM325	K	80~150	0.15~0.35	NCM325

Комплектующие



THE 25R	ETNA02506	TW07P	-
32R	ETNA0408	-	TW15S
40R	ETNA0511	-	TW20S
50R	ETNA0511	-	TW20S

Снижение себестоимости применения фрез за счет возможности применения сменной фрезерной головки.

Laser Mill

- Снижение себестоимости применения фрез за счет возможности применения сменной фрезерной головки.
- Высокая эффективность при чистовой обработке.
- Достижение высокой стойкости пластины при оптимальном выборе марки сплава.
- Простота фиксации пластины при ее замене.
- Широкий выбор корпусов: стальные, твердосплавные, модульные системы.



MQL система

- Экономичный расход СОЖ.
- Охлаждение и смазка р.к.
- Хороший отвод стружки.
- Высокая стойкость СМП и качество обработанной поверхности.

Кронштейning система

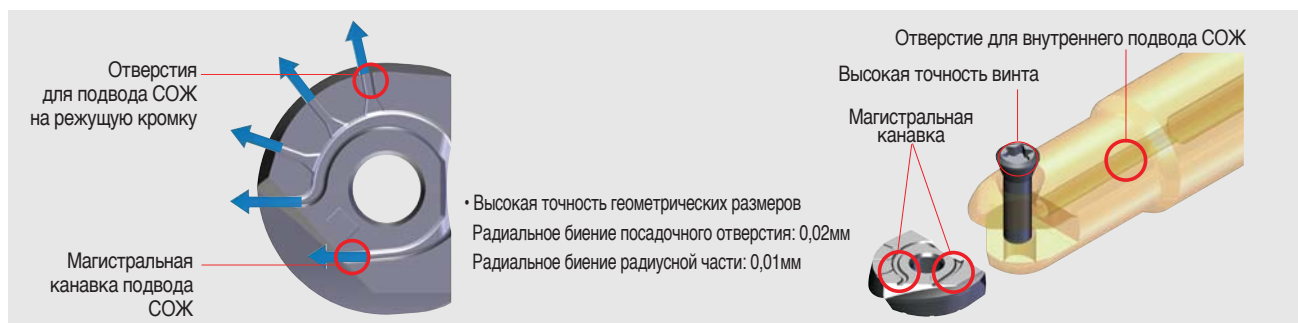

Характеристики сменной фрезерной головки

LBS, LR Каждая пластина закрепляется отдельно



- Возможность использования 6ти типов пластин на одной модульной головке
- Простота закрепления пластины при помощи одного винта.
- Возможность изготовления корпуса оправки цельным стальным, с твердосплавным сердечником или в виде модульной системы.
- Применение системы MQL (ТОЖВД - туман охлаждающей жидкости высокого давления).

LBN-Ball	LRN Радиусная вершина	LFH Высокая подача	LCF Фаска	LBS Ball тип	LR Радиусная вершина
<ul style="list-style-type: none"> • Винтовая режущая кромка • Высокая точность 	<ul style="list-style-type: none"> • Винтовая режущая кромка • Возможность выбора различных радиусов вершин пластины 	<ul style="list-style-type: none"> • Винтовая режущая кромка • Возможность применения высоких подач 	<ul style="list-style-type: none"> • Прямая режущая кромка • Высокая точность 	<ul style="list-style-type: none"> • Прямая режущая кромка • Высокая точность 	<ul style="list-style-type: none"> • Прямая режущая кромка • Возможность выбора различных радиусов вершин пластины

Улучшенная марка сплава PC210F



- Высокая прочность режущей кромки за счет ультрамелкозернистой структуры твердого сплава.
- Специальное покрытие имеет высокую эффективность при высокоскоростной обработке, при фрезеровании материалов с повышенной твердостью.
- Высокое качество обработанной поверхности за счет низкой шероховатости наружной поверхности покрытия, которое обладает «смазывающим эффектом».

Окисление температуры

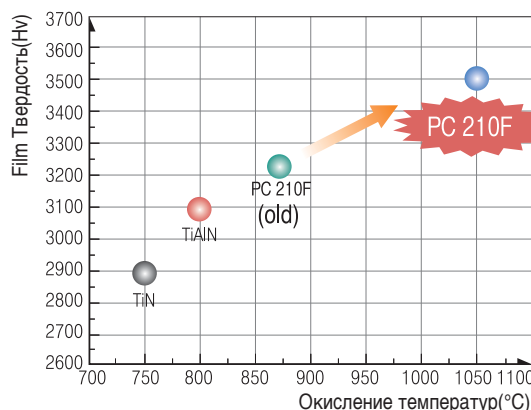

Расчет основных параметров

Скорость резания	Частота вращения
$V_p = \frac{\pi \times D \times n}{1000}, \text{м/мин}$	$n = \frac{V_p \times 1000}{\pi \times D}, \text{мин}^{-1}$
Подача	Подача
$S_z = \frac{S_{\text{мин}}}{n \times z} \text{ мм/зуб}$	$S_{\text{мин}} = S_z \times n \times z, \text{мм/мин}$
Производительность	Мощность
$Q = \frac{t \times B \times S_{\text{мин}}}{1000}, \text{см}^3/\text{мин}$	$P_c = \frac{Q \times k_c}{1000}, \text{кВт}$
	$H = \frac{P_c}{0.75}, \text{кВт}$

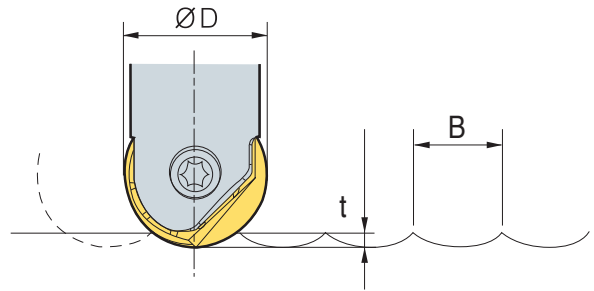

V_p = Скорость резания, м/мин	H = Мощность привода, НР
n = Частота вращения мин ⁻¹	Q = Производительность, см ³ /мин
D = Диаметр фрезы, мм	t = Глубина резания, мм
$S_{\text{мин}}$ = Подача, мм/мин	B = Ширина фрезерования, мм
S_z = Подача, мм/зуб	P_z = Сила резания, Н
z = количество зубьев	H = КПД, %
W = Мощность резания, кВт	

Рекомендуемые режимы резания

Обрабатываемые материалы	Марка сплава	Твердость	V_p , м/мин	$S_{\text{зуб}}$, мм/зуб	t		B	
					мм	мм	мм	мм
Углеродистые стали	PC210F	Ниже НRC30	100 ~ 250	0.2 ~ 0.3	0.07D		0.07D	
Углеродистые стали, славы	PC210F	НRC30 ~ 40	80 ~ 150	0.1 ~ 0.3	0.07D		0.07D	
Инструментальные стали	PC210F	НRC30 ~ 40	80 ~ 150	0.1 ~ 0.2	0.05D		0.05D	
Чугуны	PC210F	-	100 ~ 200	0.3 ~ 0.35	0.07D		0.07D	
Стали с повышенной твердости	PC210F	НRC50 ~ 60	100 ~ 150	0.1 ~ 0.3	0.03D		0.03D	
Нержавеющие стали	PC210F	-	80 ~ 150	0.1 ~ 0.3	0.05D		0.05D	
Алюминиевые сплавы	PC210F	-	200 ~ 300	0.15 ~ 0.4	0.15D		0.15D	

Расчет значений максимальной шероховатости поверхности

1. θ° Применение: Расчет скорости резания для точки P (Мгновенная скорость резания для точки P зависит от глубины тангенциального врезания)

• Расчет скорости резания

$$V_p = \frac{\pi \times D \sin \theta \times n}{1000} \text{ (м/мин)}$$

$$\theta = \cos^{-1}\left(\frac{D - 2t}{D}\right) + 90 - \alpha^\circ$$

2. Скорость резания для точки Q засчитывается по следующей зависимости

$$V_p = \frac{2\pi n \sqrt{t(D-t)}}{1000}$$

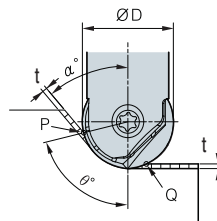

3. Формула для определения фактического диаметра

$$D_e = 2\sqrt{t(D-t)}$$

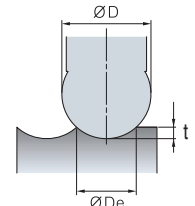

Расчет значений максимальной шероховатости поверхности

R_x , мм	h (Шероховатость) ($\mu\text{м}$)										
	0.1	0.2	0.3	0.4	0.5	0.6	0.7	0.8	0.9	1.0	
5	0.3	1.0	2.3	4.0	6.3	9.0	12.3	16.0	20.3	25.0	
6	0.2	0.8	1.9	3.3	5.2	7.5	10.2	13.3	16.9	20.8	
8	0.2	0.6	1.4	2.5	3.9	5.6	7.7	10.0	12.7	15.6	
10	0.1	0.5	1.1	2.0	3.1	4.5	6.1	8.0	10.1	12.5	
12.5	0.1	0.4	0.9	1.6	2.5	3.6	4.9	6.4	8.1	10.0	
15	0.1	0.3	0.8	1.3	2.1	3.0	4.1	5.3	6.8	8.3	
16	0.1	0.3	0.7	1.3	2.0	2.8	3.8	5.0	6.3	7.8	

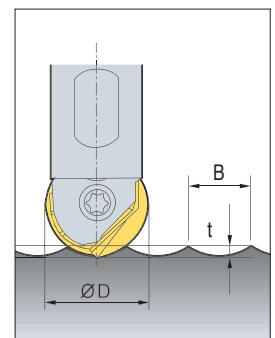

• Формула шероховатости поверхности : $отделка\ поверхности = \frac{(ae)^2}{8R} \times 1000 (\mu\text{м})$



Определение фактического диаметра обработки

t \ ØD	Ø08	Ø10	Ø12	Ø16	Ø20	Ø25	Ø30	Ø32
0.1	1.8	2.0	2.2	2.5	2.8	3.2	3.5	3.6
0.2	2.5	2.8	3.1	3.6	4.0	4.5	4.9	5.0
0.3	3.0	3.4	3.7	4.3	4.9	5.4	6.0	6.2
0.5	3.9	4.4	4.8	5.6	6.2	7.0	7.7	7.9
1.0	5.3	6.0	6.6	7.7	8.7	9.8	10.8	11.1
1.5	6.2	7.1	7.9	9.3	10.5	11.9	13.1	13.5
2.0	6.9	8.0	8.9	10.6	12.0	13.6	15.0	15.5
2.5	7.4	8.7	9.7	11.6	13.2	15.0	16.6	17.2
3.0	7.7	9.2	10.4	12.5	14.3	16.2	18.0	18.7
3.5	7.9	9.5	10.9	13.2	15.2	17.3	19.3	20.0
4.0	8.0	9.8	11.3	13.9	16.0	18.3	20.4	21.2
5.0			11.8	14.8	17.3	20.0	22.4	23.2
6.0			12.0	15.5	18.3	21.4	24.0	25.0
7.0				15.9	19.1	22.4	25.4	26.5
8.0				16.0	19.6	23.3	26.5	27.7
10.0					20.0	24.5	28.3	29.7

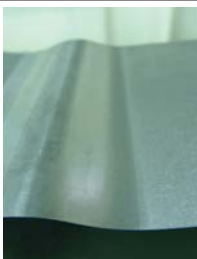
Результаты испытаний пластин на стойкость

Условия обработки		Фотографии пластин после испытаний			
 NAK80 (HRC30) Vp=376 м/мин Sz=2,5 мм/зуб t=1,5 мм B=30 мм Sмин=4000 мм/мин n=6000 об/мин Стойкость: 15 часов	Задняя поверхность	PC210F	Старомодный	Конкуренты А	
		PC210F	Старомодный	Конкуренты А	
	Передняя поверхность	PC210F	Старомодный	Конкуренты А	
		PC210F	Старомодный	Конкуренты А	
	 SKD11 (HRC50 65) Vp=251 м/мин Sz=0,38 мм/зуб t=0,5 мм B=0,3 мм Sмин=3000 мм/мин n=4000 об/мин Стойкость: 9 часов	Задняя поверхность	PC210F	Старомодный	Конкуренты А
			PC210F	Старомодный	Конкуренты А
Передняя поверхность		PC210F	Старомодный	Конкуренты А	
		PC210F	Старомодный	Конкуренты А	

Результаты испытаний пластин при обработке различных деталей

Штамп коленчатого вала		Матрица		Пресформа автомобильного бампера	
Обработываемый материал	Сталь 40ХФА (HRC40)	Обработываемый материал	Сталь 655 (HRC35) Углеродистая сталь	Обработываемый материал	Сталь 40ХММ(HRC30~35)
Режимы резания	Vp=376 м/мин, Sz=0,25 мм/зуб, t=0,5 мм, B=0,2 мм, Sмин=3000 мм/мин, n=6000 об/мин, MQL	Режимы резания	Vp=200 м/мин, Sz=0,25 мм/зуб, t=0,5 мм, B=0,5 1,0 мм, Sмин=1500 мм/мин, n=3000 об/мин. Охлаждение воздух	Режимы резания	Vp=700 м/мин, Sz=0,25 мм/зуб, t=0,5 мм, B=0,2 мм, Sмин=4500 мм/мин, n=9000 об/мин. Охлаждение воздух
Пластина Корпус фрезы	LBE200115T-S25 LBH200 (PC210F)	Пластина Корпус фрезы	LBE230-HSKC63 LBH230 (PC210F)	Пластина Корпус фрезы	LBE250170S-S25C LBH250 (PC210F)

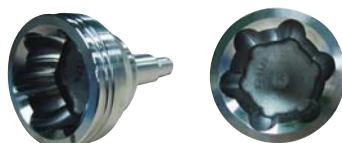
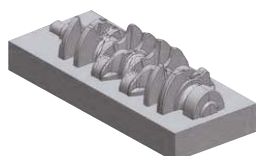

Высокая точность спиральной режущей кромки

GBE

- Высокая эффективность черновой и получистовой обработки пресс форм.
- Высокая износостойкость за счет высокой твердости марки сплава.
- Высокая точность спиральной режущей кромки.
- Внутренний подвод СОЖ.
- Возможность выбора стандартного или удлиненного корпуса.



Система обозначения фрез

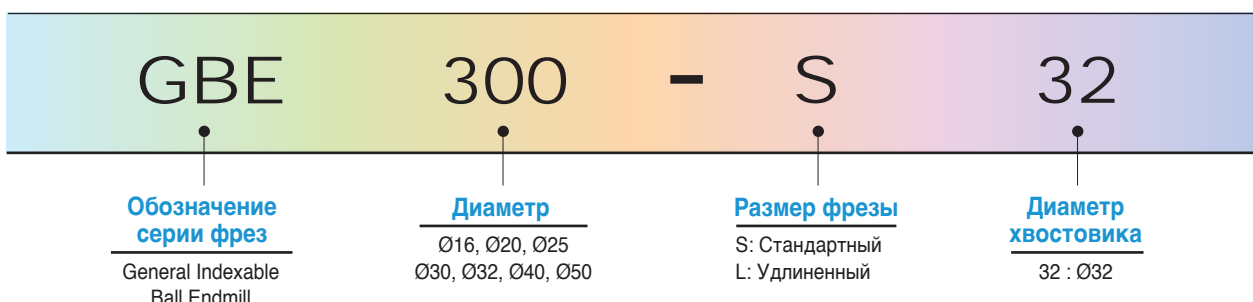

Внутренняя СМП



Опорная боковая поверхность

Наружная СМП



Паз на установочной плоскости

- ▶ Возможность достижения высокой точности обработки при значительных глубинах резания.
 - Величина износа: в пределах 0,05 мм
 - Точность R: в пределах 0,05 мм
- ▶ Возможность выбора различных диаметров фрез (Ø16, 20, 25, 30, 32, 40, 50)
- ▶ Низкая сила резания.
- ▶ Препятствие смещению СМП за счет пазов на установочной плоскости и специальной геометрии боковой опорной поверхности.
- ▶ Экономичность применения благодаря использованию двух режущих кромок.
- ▶ Высокая износостойкость новой марки сплава.



Стандартный тип



Шахматный тип



Модульный тип
(Сменная фрезерная головка)

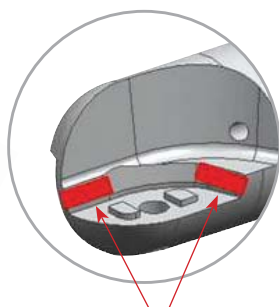

Опорные базы

- ▶ Возможность выбора различных диаметров фрез (Ø16, 20, 25, 30, 32, 40, 50).
- ▶ Хороший отвод стружки за счет внутреннего подвода СОЖ в зону резания.
- ▶ Высокое качество обработки.
- ▶ Жесткое и точное позиционирование пластин способствует снижению вибраций и улучшению качества обработки.

Руководство по сборке фрезы

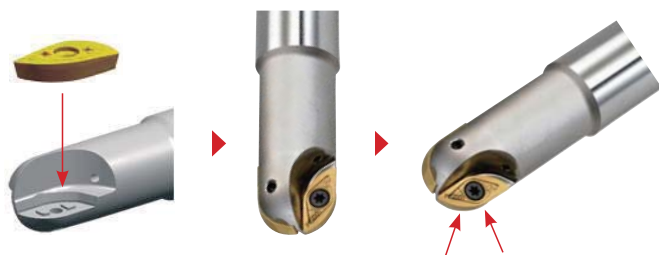

1. Установите СМП в посадочное гнездо
2. Прижмите СМП в направлении, показанном красной стрелкой и закрутите винт.

Результаты сравнительных испытаний

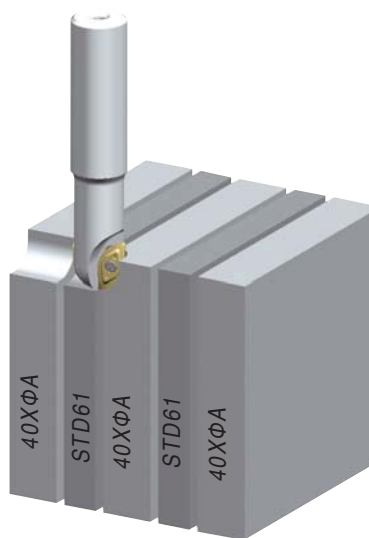
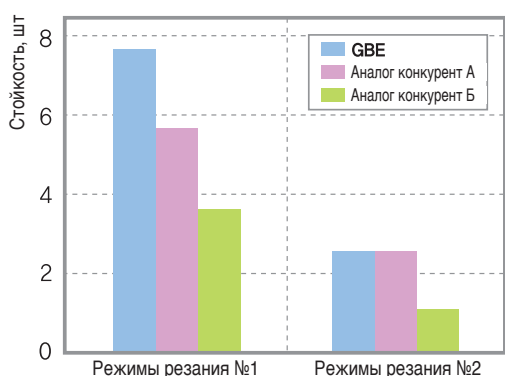

Выбор СМП и комплектующих

Режимы резания	Скорость резания, м/мин	Подача, мм/зуб	Глубина резания, мм	Ширина фрезерования, мм	Обрабатываемый материал	Охлаждение
№. 1	150	0.15	5	8	STD61(HrC50)	СОЖ
№. 2	100	0.1	8	8	40XΦA(HrC20)	

Выбор СМП и комплектующих

Диаметр фрез	СМП			Комплектующие			
	Внутренняя	Наружная	Наружная верхняя	Винт		Ключ	
Форма							
	Внутр./Наруж.	Наруж. Верхний		Внутр./Наруж.	Наруж. Верхний	Внутр./Наруж.	Наруж. Верхний
Ø16	ZPET080M-MM	ZPET080S-MM	-	FTKA02555S	-	TW08S	-
Ø20	ZPET100M-MM	ZPET100S-MM	SPMT060304	FTKA0307	ETNA02506	TW09S	TW07P
Ø25	ZPET125M-MM	ZPET125S-MM	SPMT060304	FTKA0409	ETNA02506	TW15S	TW07P
Ø30	ZPET150M-MM	ZPET150S-MM	SDMT090308-MM	FTGA0511-P	ETNA0408	TW20-100	TW15S
Ø32	ZPET160M-MM	ZPET160S-MM	SDMT090308-MM	FTGA0511-P	ETNA0408	TW20-100	TW15S
Ø40	ZPET200M-MM	ZPET200S-MM	SDMT120408-MM	FTGA0614	ETNA0511	TW20-100	TW25S
Ø50	ZPET250M-MM	ZPET250S-MM	SDMT120408-MM	FTGA0818	ETNA0511	TW25S	TW25S



Рекомендуемые режимы резания

Обрабатываемые материалы	Обрабатываемые поверхности	Твердость (HRC)	V _p , м/мин	S _z , мм/зуб	t, мм	B, мм
Углеродистые стали, легированные стали	Вертикальные, наклонные Пазы	Ниже 25	160~250	0.1~0.5	0.3~0.5D	0.2~0.3D
	Высокие вертикальные, наклонные		120~200	0.1~0.5	0.3~0.5D	-
Углеродистые стали, легированные стали	Вертикальные, наклонные Пазы	Ниже 45	160~250	0.1~0.5	1.0~1.5D	0.1~0.2D
	Высокие вертикальные, наклонные		120~200	0.1~0.5	0.3~0.5D	-
Штамповые стали	Вертикальные, наклонные Пазы	30~40	120~200	0.1~0.3	0.3~0.5D	0.2~0.3D
	Высокие вертикальные, наклонные		120~160	0.1~0.3	0.3~0.5D	-
Чугуны	Вертикальные, наклонные Пазы	20~30	120~200	0.1~0.3	1.0~1.5D	0.1~0.2D
	Высокие вертикальные, наклонные		150~300	0.2~0.7	0.3~0.5D	0.2~0.3D
Закаленные стали	Вертикальные, наклонные Пазы	50~60	150~300	0.2~0.7	0.3~0.5D	-
	Высокие вертикальные, наклонные		150~300	0.2~0.7	1.0~1.5D	0.1~0.2D

Линейка сферических концевых фрез

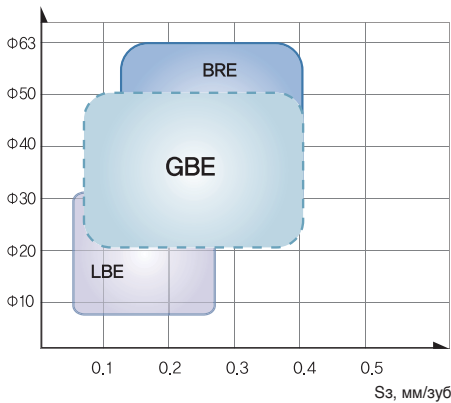

Серия	Критерии оценки фрез				
	Качество и точность обработки	Производительность	Диапазон диаметров	Экономичность	Обработка глубоких карманов
Laser Mill	●	○	◐	○	○
GBE	◐	●	◐	◐	●
BRE	○	●	●	●	●

● : Отлично ◐ : Хорошо ○ : Удовлетворительно

Результаты сравнительных испытаний

Режимы резания		Фотографии изношенных СМП				
Изображение	Параметры	Вид поверхности	GBE	Аналог конкурент А	Аналог конкурент В	
			<p>Машинное время 4 прохода</p>	<ul style="list-style-type: none"> Обрабатываемые материалы: Легированная сталь (HRC33), сухое резание Режимы резания: V_p=280 м/мин, S_z=0,25 мм/зуб, t=5 мм, B=5 мм, S_{мин}=1,486 м/мин, поб=2,971 об/мин Инструмент: Державка: GBE300-S32, СМП: ZPET150M-MM(PC3500), ZPET150S-MM(PC3500) 	Верхняя поверхность	Внутренняя
Боковая поверхность	Внутренняя					
	Верхняя поверхность	Внутренняя				
Боковая поверхность		Внутренняя				
	<p>Машинное время 4 прохода</p>	<ul style="list-style-type: none"> Обрабатываемые материалы: Сталь X12 (HRC22), сухое резание Режимы резания: V_p=250 м/мин, S_z=0,2 мм/зуб, t=5 мм, B=5 мм, S_{мин}=1,062 м/мин, поб=2,653 об/мин Инструмент: Державка: GBE300-S32, СМП: ZPET150M-MM(PC3500), ZPET150S-MM(PC3500) 	Верхняя поверхность	Внутренняя		
Боковая поверхность				Внутренняя		
			Верхняя поверхность	Внутренняя		
Боковая поверхность				Внутренняя		



Улучшенная геометрия стружечной канавки, препятствующая пакетированию стружки.

BRE

- Процесс резания : Хорошее удаление стружки из зоны резания, невысокие силы резания, отсутствие вибраций.
- Корпус фрезы : Высокая эксплуатационная надежность, устойчивость к деформациям и поломкам, специальная обработка поверхности, повышающая ее износостойкость.
Простота и надежность винтового крепления СМП формы TCRX.
- Улучшенная геометрия стружечной канавки, препятствующая пакетированию стружки.
- СМП : Возможность применения высоких скоростей резания и подач за счет специальной марки сплава обеспечивающей высокую износостойкость и устойчивость к выкрашиванию.
Высокая прочность режущей кромки и значительный передний угол.

Корпус фрезы оснащен СМП по стандарту ISO



- Низкое трение стружки
- Хороший теплоотвод

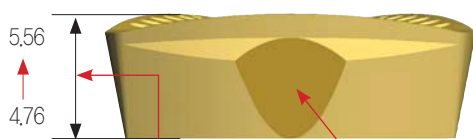

- Повышенная точность режущей кромки за счет увеличенной высоты

- Улучшенное распределение нагрузки при врезании



Рекомендуемые режимы резания для фрез серии «BRE» при черновой обработке

Тип 1	Тип 2	Тип 3
$t=0.3D - 0.5D$	$B=0.2D - 0.3D$ $t=0.3D - 0.5D$	$B=0.1D - 0.5D$ $t=1.2D - 1.5D$

Обрабатываемые материалы	Тип обрабатываемой поверхности	Скорость резания, м/мин	Подача, мм/зуб	Марка сплава
Углеродистые, легированные стали	1	120~220	0.1~0.4	NCM325
	2	120~220	0.2~0.4	NCM325
	3	100~180	0.1~0.3	NCM325
Легированные стали	1	100~200	0.1~0.4	NCM325
	2	100~200	0.2~0.4	NCM325
	3	80~160	0.1~0.3	NCM325
Инструментальные стали	1	80~150	0.1~0.3	NCM325
	2	80~150	0.15~0.35	NCM325
	3	60~120	0.1~0.3	NCM325
Закаленные стали (H _v 35-45)	1	60~120	0.1~0.3	NCM325
	2	60~120	0.1~0.3	NCM325
	3	50~80	0.1~0.2	NCM325
Чугуны	1	100~180	0.2~0.5	NCM320K
	2	100~180	0.2~0.5	NCM320K
	3	80~160	0.15~0.4	NCM320K

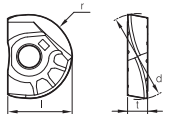
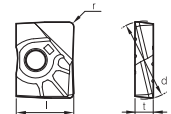
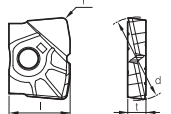
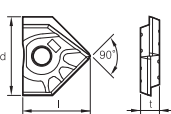
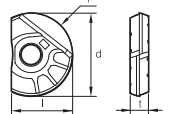
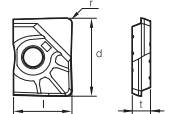

Применяемые СМП

Корпус фрезы	LBH (Сферический тип)	LRH (Радиусные вершины)	LFH (Высокая подача)	LCF (Фасочный тип)	LBS (Сферический тип)	LR (Радиусные вершины)
	 Точность R ± 0,005 мкм	 Точность r ± 0,015 мкм			 Точность R ± 0,005 мкм	 Точность r ± 0,015 мкм
LBE080	LBH080 LBH090				LBS080 LBS090	
LBE100 LRE100	LBH100 LBH110	LRH100-R05 LRH100-R20 LRH100-R10 LRH110-R05	LFH100		LBS100 LBS110	LR100-R05 LR100-R20 LR100-R10 LR110-R05
LBE120 LRE120	LBH120 LBH130	LRH120-R05 LRH120-R20 LRH120-R10 LRH130-R05	LFH120		LBS120 LBS130	LR120-R05 LR120-R20 LR120-R10 LR130-R05
LBE160 LRE160	LBH160 LBH170	LRH160-R05 LRH160-R30 LRH160-R10 LRH170-R05 LRH160-R20	LFH160	LCF160-D90	LBS160 LBS170	LR160-R05 LR160-R30 LR160-R10 LR170-R05 LR160-R20
LBE200 LRE200	LBH200 LBH210	LRH200-R05 LRH200-R30 LRH200-R10 LRH210-R05 LRH200-R20	LFH200	LCF200-D90	LBS200 LBS210	LR200-R05 LR200-R30 LR200-R10 LR210-R05 LR200-R20
LBE250 LRE250	LBH250 LBH260	LRH250-R05 LRH250-R30 LRH250-R10 LRH260-R05 LRH250-R20	LFH250	LCF250-D90	LBS250 LBS260	LR250-R05 LR250-R30 LR250-R10 LR260-R05 LR250-R20
LBE300 LRE300	LBH300 LBH310	LRH300-R10 LRH300-R30 LRH300-R20 LRH310-R05	LFH300		LBS300 LBS310	LR300-R10 LR300-R30 LR300-R20 LR310-R05
LBE320 LRE320	LBH320	LRH320-R10 LRH320-R30 LRH320-R20	LFH320		LBS320	LR320-R10 LR320-R30 LR320-R20

 Применяемые СМП смотреть на стр. E08



Твердосплавных хвостовик

LBE 08/10/12/16/20/25/30/32

Цилиндрическая шейка



Рис. 1



Рис. 2

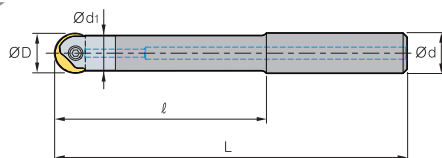

Обозначение		$\varnothing D$	$\varnothing d$	$\varnothing d_1$	ℓ	L	Комплектующие		Применяемые пластины(\varnothing)	Рис.
							Винт	Ключ		
LBE	080080S-S08C	8,9	8	7.5	80	136	ETND02506F	TWP07S	8,9	1
	080100S-S08C	8,9	8	7.5	100	156				
	080020S-S08C-130	8,9	8	7.5	20	130				
	080020S-S08C-150	8,9	8	7.5	20	150	ETND02506F	TWP07S	8,9	2
	100080S-S10C	10,11	10	9.5	80	136				
	100120S-S10C	10,11	10	9.5	120	176	ETND0307F	TWP08S	10,11	1
	100023S-S10C-130	10,11	10	9.5	23	130				
	100023S-S10C-170	10,11	10	9.5	23	170				
	120100S-S12C	12,13	12	11.5	100	156	ETND03509	TWP10S	12,13	1
	120150S-S12C	12,13	12	11.5	150	206				
	120025S-S12C-150	12,13	12	11.5	25	150	ETND03509	TWP10S	12,13	2
	120025S-S12C-200	12,13	12	11.5	25	200				
	160100S-S16C	16,17	16	15.5	100	160				
	160150S-S16C	16,17	16	15.5	150	210	ETND0413	TWP15S	16,17	1
	160030S-S16C-160	16,17	16	15.5	30	160				
	160030S-S16C-210	16,17	16	15.5	30	210				
	200120S-S20C	20,21	20	19.5	120	190	ETKD0516	TWP20	20,21	1
	200170S-S20C	20,21	20	19.5	170	240				
	200035S-S20C-190	20,21	20	19.5	35	190	ETKD0516	TWP20	20,21	2
	200035S-S20C-240	20,21	20	19.5	35	240				
	250140S-S25C	25,26	25	24.5	140	220				
	250170S-S25C	25,26	25	24.5	170	250	ETKD0620	TWP25	25,26	1
	250040S-S25C-220	25,26	25	24.5	40	220				
	250040S-S25C-250	25,26	25	24.5	40	250				
	300140S-S32C	30,31	32	29.5	140	230	ETGD0825	TWP40	30,31	1
	300170S-S32C	30,31	32	29.5	170	260				
	300050S-S32C-230	30,31	32	29.5	50	230	ETGD0825	TWP40	30,31	2
	300050S-S32C-260	30,31	32	29.5	50	260				
	320140S-S32C	32	32	31.5	140	230				
	320170S-S32C	32	32	31.5	170	260	ETGD0825	TWP40	32	1
	320050S-S32C-230	32	32	31.5	50	230				
	320050S-S32C-260	32	32	31.5	50	260	ETGD0825	TWP40	32	2

(мм)

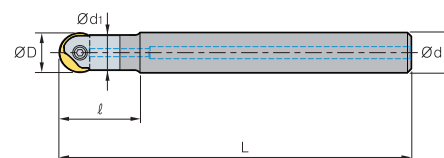

Твердосплавных хвостовик

LBE08/10/12/16/20/25/30/32

Коническая шейка

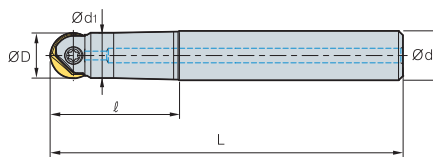

Обозначение	ØD	Ød	Ød1	ℓ	L	Комплектующие		Применяемые пластины(Ø)
						Винт	Ключ	
LBE 080035T-S12	8,9	12	7.5	35	91	ETND02506F	TWP07S	8, 9
080055T-S12	8,9	12	7.5	55	111			
080075T-S12	8,9	12	7.5	75	131			
100035T-S12	10,11	12	9.5	35	91	ETND0307F	TWP08S	10, 11
100055T-S12	10,11	12	9.5	55	111			
100075T-S12	10,11	12	9.5	75	131			
120055T-S12	12,13	12	10.4	55	111	ETND03509	TWP10S	12, 13
120085T-S16	12,13	16	11.5	85	145			
160065T-S16	16,17	16	14	65	125			
160100T-S20	16,17	20	15.5	100	170	ETND0413	TWP15S	16, 17
200075T-S20	20,21	20	17.5	75	145			
200115T-S25	20,21	25	19.5	115	195			
250090T-S25	25,26	25	22	90	170	ETKD0620	TWP25	25, 26
250135T-S32	25,26	32	24.5	135	225			
300105T-S32	30,31	32	29.5	105	195			
300160T-S32	30,31	32	29.5	160	250	ETGD0825	TWP40	30, 31
320105T-S32	32	32	29	105	195			
320160T-S32	32	32	29	160	250			

Стальной хвостовик

LBE12/16/20/25/30/32

Цилиндрическая шейка

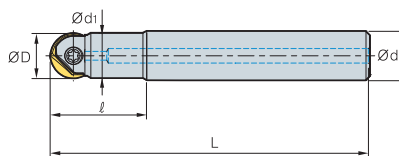

Обозначение	ØD	Ød	Ød1	ℓ	L	Комплектующие		Применяемые пластины(Ø)
						Винт	Ключ	
LBE 120035S-S12	12,13	12	11.5	35	91	ETND03509	TWP10S	12,13
160035S-S16	16,17	16	15.5	35	95	ETND0413	TWP15S	16,17
200040S-S20	22,21	20	19.5	40	110	ETKD0516	TWP20	20,21
250045S-S25	25,26	25	24.5	40	125	ETKD0620	TWP25	25,26
300055S-S32	30,31	32	29.5	55	145	ETGD0825	TWP40	30,31
320055S-S32	32	32	31.5	55	145	ETGD0825	TWP40	32

Твердосплавных хвостовик LRE10/12/16/20/25/30/32

Коническая шейка



Рис. 1



Рис. 2

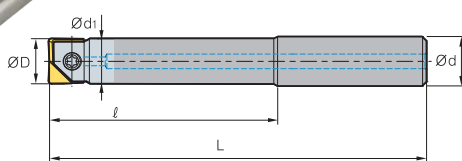

Обозначение		$\varnothing D$	$\varnothing d$	$\varnothing d_1$	ℓ	L	Комплектующие		Применяемые пластины(\varnothing)	Рис.
						Винт	Ключ			
LRE	100080S-S10C	10, 11	10	9.5	80	136	ETND0307F	TWP08S	10, 11	1
	100120S-S10C	10, 11	10	9.5	120	176				2
	100023S-S10C-130	10, 11	10	9.5	23	130	ETND0307F	TWP08S	10, 11	1
	100023S-S10C-170	10, 11	10	9.5	23	170				2
	120100S-S12C	12, 13	12	11.5	100	156	ETND03509	TWP10S	12, 13	1
	120150S-S12C	12, 13	12	11.5	150	206				1
	120025S-S12C-150	12, 13	12	11.5	25	150	ETND03509	TWP10S	12, 13	2
	120025S-S12C-200	12, 13	12	11.5	25	200				2
	160100S-S16C	16, 17	16	15.5	100	160	ETND0413	TWP15S	16, 17	1
	160150S-S16C	16, 17	16	15.5	150	210				1
	160030S-S16C-160	16, 17	16	15.5	30	160	ETND0413	TWP15S	16, 17	2
	160030S-S16C-210	16, 17	16	15.5	30	210				2
	200120S-S20C	20, 21	20	19.5	120	190	ETKD0516	TWP20	20, 21	1
	200170S-S20C	20, 21	20	19.5	170	240				1
	200035S-S20C-190	20, 21	20	19.5	35	190	ETKD0516	TWP20	20, 21	2
	200035S-S20C-240	20, 21	20	19.5	35	240				2
	250140S-S25C	25, 26	25	24.5	140	220	ETKD0620	TWP25	25, 26	1
	250170S-S25C	25, 26	25	24.5	170	250				1
	250040S-S25C-220	25, 26	25	24.5	40	220	ETKD0620	TWP25	25, 26	2
	250040S-S25C-250	25, 26	25	24.5	40	250				2
	300140S-S32C	30, 31	32	29.5	140	230	ETGD0825	TWP40	30, 31	1
	300170S-S32C	30, 31	32	29.5	170	260				1
	300050S-S32C-230	30, 31	32	29.5	50	230	ETGD0825	TWP40	30, 31	2
	300050S-S32C-260	30, 31	32	29.5	50	260				2
	320140S-S32C	32	32	31.5	140	230	ETGD0825	TWP40	32	1
	320170S-S32C	32	32	31.5	170	260				1
	320050S-S32C-230	32	32	31.5	50	230	ETGD0825	TWP40	32	2
	320050S-S32C-260	32	32	31.5	50	260				2

(мм)

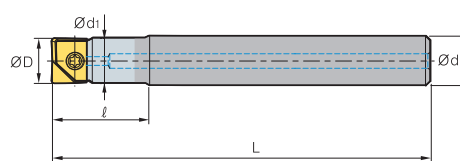
Стальной хвостовик LRE10/12

Цилиндрическая шейка

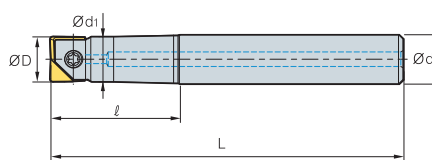

Обозначение		$\varnothing D$	$\varnothing d$	$\varnothing d_1$	ℓ	L	Комплектующие		Применяемые пластины(\varnothing)
						Винт	Ключ		
LRE	100025T-S12	10, 11	12	9.5	25	111	ETND0307F	TWP08S	10, 11
	100050T-S12	10, 11	12	9.5	50	150			
	120060T-S16	12, 13	16	11.5	60	160	ETND03509	TWP10S	12, 13

(мм)



Стальной хвостовик LRE12/16/25/30/32

Цилиндрическая шейка

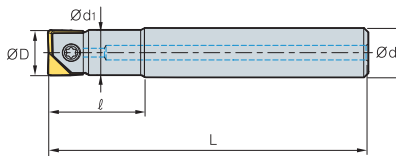

Обозначение	$\varnothing D$	$\varnothing d$	$\varnothing d_1$	ℓ	L	Комплектующие		Применяемые пластины(\varnothing)
						Винт	Ключ	
LRE 120030S-S12	12, 13	12	11.5	30	111	ETND03509	TWP10S	12, 13
160050S-S16	16, 17	16	15.5	50	131	ETND0413	TWP15S	16, 17
160060S-S16	16, 17	16	15.5	60	160			
200060S-S20	20, 21	20	19.5	60	145	ETKD0516	TWP20	20, 21
200080S-S20	20, 21	20	19.5	80	180			
250070S-S25	25, 26	25	24.5	70	145	ETKD0620	TWP25	25, 26
250100S-S25	25, 26	25	24.5	100	225			
300070S-S32	30, 31	32	29.5	70	160	ETGD0825	TWP40	30, 31
300100S-S32	30, 31	32	29.5	100	225			
320080S-S32	32	32	31.5	80	160	ETGD0825	TWP40	32
320100S-S32	32	32	31.5	100	225			

Применяемые СМП E07, E08

• Т – стандартный тип, S – усиленный тип

LBE-MHD

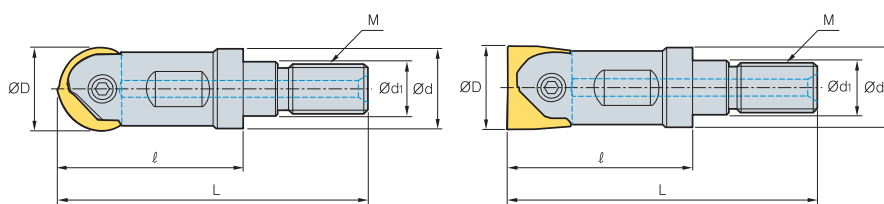

Обозначение	M	$\varnothing D$	L	ℓ	$\varnothing d$	$\varnothing d_1$	Комплектующие		Применяемые пластины(\varnothing)
							Винт	Ключ	
LBE 100-MHD-M06	M06	10, 11	40	25	9.5	6.5	ETND0307F	TWP08S	10, 11
120-MHD-M06	M06	12, 13	40	25	11	6.5	ETND03509	TWP10S	12, 13
160-MHD-M08	M08	16, 17	47	30	14.5	8.5	ETND0413	TWP15S	16, 17
200-MHD-M10	M10	20, 21	56	35	18	10.5	ETKD0516	TWP20	20, 21
250-MHD-M12	M12	25, 26	69	45	22.5	12.5	ETKD0620	TWP25	25, 26
300-MHD-M16	M16	30, 31	77	50	28	17	ETGD0825	TWP40	30, 31
320-MHD-M16	M16	32	77	50	29	17	ETGD0825	TWP40	32

Обозначение : LBE320-MHD-M16
Фрезерная головка с резьбой(M16)

Оправка : MAT-M16-035-S32S
Присоединительная резьба оправки(M16)

Применяемые СМП смотреть на стр. E08

Применяемые оправки смотреть на стр. E233~E234

BFE



Рис. 1



Рис. 2

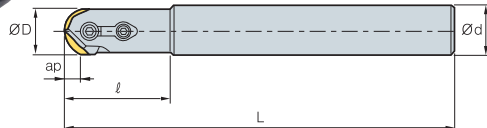

Обозначение		ØD	ød	ℓ	L	ap		Рис.	Применяемые пластины(Ø)
BFE	16-S	16	16	36	140	8.0	0.2	1	RC16
	16-M	16	20	65	170	8.0	0.3	2	
	16-L	16	25	65	200	8.0	0.5	2	
	20-S	20	20	45	160	10.0	0.4	1	RC20
	20-M	20	25	80	200	10.0	0.6	2	
	20-L	20	25	80	250	10.0	0.8	2	
	25-S	25	25	45	160	12.5	0.7	1	RC25
	25-M	25	32	90	210	12.5	1.1	2	
	25-L	25	32	90	300	12.5	1.7	2	
	30-S	30	32	65	175	15.0	0.9	2	RC30
	30-M	30	32	100	250	15.0	1.4	2	
	30-L	30	32	100	350	15.0	2.0	2	
	32-S	32	32	56	175	16.0	0.9	1	RC32
	32-M	32	32	100	250	16.0	1.4	1	
	32-L	32	32	100	350	16.0	2.0	1	

Применяемые СМП

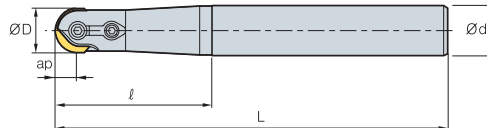
RC		Тв. сплав с покрытием		Стр.
Обозначение		RC210F		
RC	16	●	E12	
	20	●		
	25	●		
	30	●		
	32	●		

Рекомендуемые режимы резания

Обрабатываемые материалы	Режимы резания	
	V _p , м/мин	S _z , мм/зуб
Углеродистые стали (Выше HB180)	150 ~ 250	0.10 ~ 0.30
Легированные стали, сплавы (Ниже HB300)	100 ~ 200	0.10 ~ 0.20
Чугуны (ниже HB300)	100 ~ 200	0.10 ~ 0.30

Комплектующие



Ø16	FTGA0513	CBH4.5R1	CTX04513	ER03	TW20
Ø20	FTGA0517	CBH4.5R2	CTX04513	ER03	TW20
Ø25	FTGA0621	CBH5R1	CTX0517	ER04	TW20
Ø30, 32	FTGA0826	CBH6R1	CTX0621	ER05	TW25



ГВЕ (Нормальная длина рабочей части)

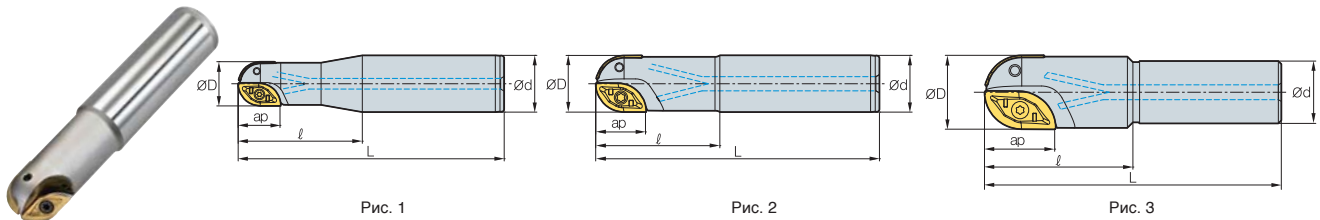

Обозначение	Геометрические размеры					Применяемые СМП			Комплектующие				Рис.
	ØD	Ød	l	L	ap	Внутренняя	Наружная	Наружная верхняя	Винт		Ключ		
									Сферическая часть	Цилиндрическая часть	Сферическая часть	Цилиндрическая часть	
ГВЕ 160-S20	16	20	50	130	15	ZPET080M-MM	ZPET080S-MM	-	FTKA02555S	-	TW08S	-	1
160-L20	16	20	90	200	15	ZPET080M-MM	ZPET080S-MM	-	FTKA02555S	-	TW08S	-	1
200-S25	20	25	60	140	18	ZPET100M-MM	ZPET100S-MM	-	FTKA0307	-	TW09S	-	1
200-L25	20	25	80	250	18	ZPET100M-MM	ZPET100S-MM	-	FTKA0307	-	TW09S	-	1
250-S32	25	32	70	150	23	ZPET125M-MM	ZPET125S-MM	-	FTKA0409	-	TW15S	-	1
250-L32	25	32	100	300	23	ZPET125M-MM	ZPET125S-MM	-	FTKA0409	-	TW15S	-	1
300-S32	30	32	70	160	27	ZPET150M-MM	ZPET150S-MM	-	FTGA0511-P	-	TW20-100	-	2
300-L32	30	32	120	350	27	ZPET150M-MM	ZPET150S-MM	-	FTGA0511-P	-	TW20-100	-	2
320-S32	32	32	70	160	28	ZPET160M-MM	ZPET160S-MM	-	FTGA0511-P	-	TW20-100	-	2
320-L32	32	32	120	350	28	ZPET160M-MM	ZPET160S-MM	-	FTGA0511-P	-	TW20-100	-	2
400-S42	40	42	100	200	37	ZPET200M-MM	ZPET200S-MM	-	FTGA0614	-	TW20-100	-	2
400-L42	40	42	150	350	37	ZPET200M-MM	ZPET200S-MM	-	FTGA0614	-	TW20-100	-	2
500-S42	50	42	100	200	47	ZPET250M-MM	ZPET250S-MM	-	FTGA0818	-	TW25-100	-	3
500-L42	50	42	100	350	47	ZPET250M-MM	ZPET250S-MM	-	FTGA0818	-	TW25-100	-	3

ГВЕ-М (Удлиненная рабочая часть)

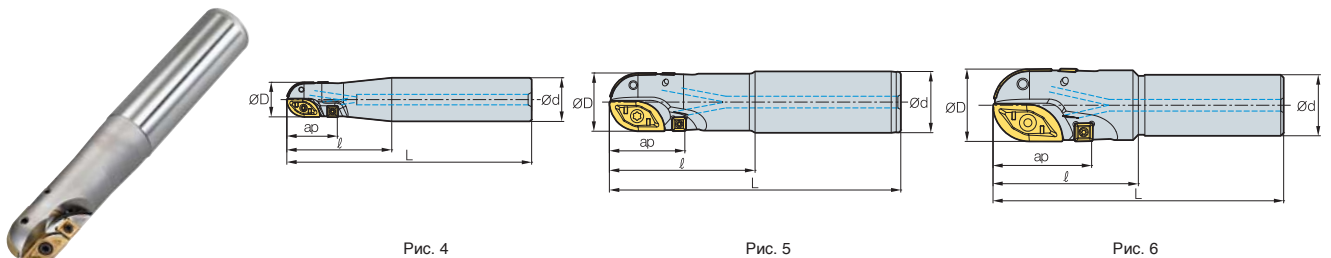

Обозначение	Геометрические размеры					Применяемые СМП			Комплектующие				Рис.
	ØD	Ød	l	L	ap	Внутренняя	Наружная	Наружная верхняя	Винт		Ключ		
									Сферическая часть	Цилиндрическая часть	Сферическая часть	Цилиндрическая часть	
ГВЕ 200M-S25	20	25	70	150	28	ZPET100M-MM	ZPET100S-MM	SPMT060304	FTKA0307	ETNA02506	TW09S	TW07P	4
200M-L25	20	25	70	250	28	ZPET100M-MM	ZPET100S-MM	SPMT060304	FTKA0307	ETNA02506	TW09S	TW07P	4
250M-S32	25	32	80	180	33	ZPET125M-MM	ZPET125S-MM	SPMT060304	FTKA0409	ETNA02506	TW15S	TW07P	4
250M-L32	25	32	80	300	33	ZPET125M-MM	ZPET125S-MM	SPMT060304	FTKA0409	ETNA02506	TW15S	TW07P	4
300M-S32	30	32	100	200	41	ZPET150M-MM	ZPET150S-MM	SDMT090308-MM	FTGA0511-P	ETNA0408	TW20-100	TW15S	4
300M-L32	30	32	100	350	41	ZPET150M-MM	ZPET150S-MM	SDMT090308-MM	FTGA0511-P	ETNA0408	TW20-100	TW15S	4
320M-S32	32	32	100	200	42	ZPET160M-MM	ZPET160S-MM	SDMT090308-MM	FTGA0511-P	ETNA0408	TW20-100	TW15S	5
320M-L32	32	32	100	350	42	ZPET160M-MM	ZPET160S-MM	SDMT090308-MM	FTGA0511-P	ETNA0408	TW20-100	TW15S	5
400M-S42	40	42	100	200	56	ZPET200M-MM	ZPET200S-MM	SPMT120408-MM	FTGA0614	ETNA0511	TW20-100	TW20S	5
400M-L42	40	42	100	350	56	ZPET200M-MM	ZPET200S-MM	SPMT120408-MM	FTGA0614	ETNA0511	TW20-100	TW20S	5
500M-S42	50	42	100	200	67	ZPET250M-MM	ZPET250S-MM	SPMT120408-MM	FTGA0818	ETNA0511	TW25-100	TW20S	6
500M-L42	50	42	100	350	67	ZPET250M-MM	ZPET250S-MM	SPMT120408-MM	FTGA0818	ETNA0511	TW25-100	TW20S	6



GBEM

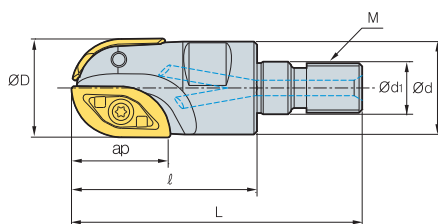

(мм)

Обозначение	Геометрические размеры							Применяемые СМП	
	ØD	Ød	Ød1	l	L	M	ap	Внутренняя	Наружная
GBEM 160-M08	16	15	8.5	30	47	M08	15	ZPET080M-MM	ZPET080S-MM
200-M10	20	18.6	10.5	35	56	M10	18	ZPET100M-MM	ZPET100S-MM
250-M12	25	23.2	12.5	45	69	M12	23	ZPET125M-MM	ZPET125S-MM
300-M16	30	27.8	17	50	77	M16	27	ZPET150M-MM	ZPET150S-MM
320-M16	32	29.8	17	50	77	M16	28	ZPET160M-MM	ZPET160S-MM

Применяемые СМП

Обозначение	Тв. сплав с покрытием				Стр.
	NCM325	PC3500	PC5300	PC3545	
ZPET 080M-MM		●			E24
100M-MM		●			
125M-MM		●			
150M-MM		●			
160M-MM		●			
200M-MM		●			
250M-MM					
ZPET 080S-MM		●			
100S-MM		●			
125S-MM		●			
150S-MM		●			
160S-MM		●			
200S-MM		●			
250S-MM					
SPMT 060304	●				E21
SDMT 090308-MM		●			E14
SPMT 120408-MM		●		●	E21

Комплектующие

Винт		Ключ		Диаметр фрезы, мм
Сферическая часть	Цилиндрическая часть	Сферическая часть	Цилиндрическая часть	
FTKA02555	-	TW08S	-	Ø 16
FTKA0307	ETNA02506	TW09S	TW07P	Ø 20
FTKA0409	ETNA02506	TW15S	TW07P	Ø 25
FTGA0511-P	ETNA0408	TW20-100	TW15S	Ø 30
FTGA0511-P	ETNA0408	TW20-100	TW15S	Ø 32

Обозначение : GBEM320-M16
Фрезерная головка с резьбой(M16)

||

Оправка : MAT-M16-035-S32S
Присоединительная резьба оправки(M16)

BRE

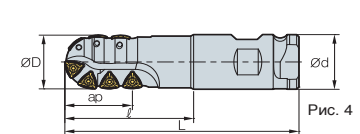
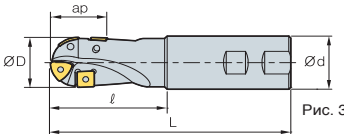
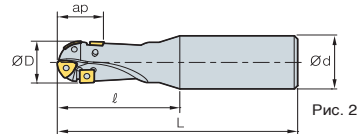
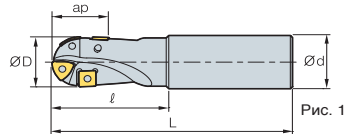

• AR : 0°~10°
• RR : -3°~0°

Обозначение	ØD	Ød	l	L	ap	Применяемые СМП		Комплектующие		Рис.					
						Торцевые	Периферийные	Винт	Ключ						
BRE 20R-S	20	20	50	125	20	ZDMT080310R-MM	SPMT060304	ETNA02506	TW07P	0.3	1				
20R-M	20	20	75	150	20					0.3	1				
20R-L	20	25	100	200	20					0.3	2				
20R-SL	20	25	65	125	20					0.3	3				
25R-S	25	25	70	150	23	ZDMT110312.5R-MM	SPMT060304	ETNA02506	TW07P	0.5	1				
25R-M	25	25	95	175	23					0.5	1				
25R-L	25	32	100	200	23					0.4	2				
25R-SL	25	25	75	135	23					0.4	3				
32R-S	32	32	85	175	31	ZDMT130416R-MM	SDMT090308-MM	ETNA0408	TW15S	0.9	1				
32R-M	32	32	100	200	31					0.9	1				
32R-L	32	32	150	250	31					0.7	1				
32R-SL	32	32	75	150	31					0.7	3				
40R-S	40	42	85	175	41	ZPMT160520R-MM	SPMT120408-MM SPMT120508-MMN	ETNA0511	TW20-100	1.3	1				
40R-S-40	40	42	85	175	41					1.3	1				
40R-M	40	42	100	200	41					1.3	1				
40R-M-40	40	42	100	200	41					1.3	1				
40R-L	40	42	150	250	41					1.3	1				
40R-L-40	40	42	150	250	41					1.3	1				
40R-SL	40	42	80	160	41					1.3	3				
40R-SL-40	40	42	80	160	41					1.3	3				
50R-S	50	42	100	200	45					ZPMT160525R-MM	SPMT120408-MM SPMT120508-MMN	ETNA0511	TW20-100	2.6	1
50R-S-40	50	42	100	200	45									2.6	1
50R-L	50	42	100	300	45	2.6	1								
50R-L-40	50	42	100	300	45	2.6	1								
50R-SL	50	42	100	250	45	ZPMT160531.5R-MM	SPMT120408-MM SPMT120508-MMN	ETNA0511	TW20-100	2.6	3				
50R-SL-40	50	42	100	250	45					2.6	3				
63R-S	63	42	100	200	52					3.0	1				
63R-S-40	63	42	100	200	52					3.0	1				
63R-L	63	42	100	300	52	ZPMT160520R-MM		ETNA0511	TW20-100	3.0	1				
63R-L-40	63	42	100	300	52					3.0	1				
63R-SL	63	42	100	250	52					3.0	1				
63R-SL-40	63	42	100	250	52					3.0	3				
40XR-SC40	40	40	110	200	54	ZPMT160520R-MM		ETNA0511	TW20-100	1.4	4				
40XR-LC40	40	40	150	250	54					1.9	4				
50XR-SC50.8	50	50.8	110	200	57	ZPMT160525R-MM		ETNA0511	TW20-100	2.3	4				
50XR-LC50.8	50	50.8	150	250	57					3.0	4				

Применяемые СМП

SDMT-MM SPMT SPMT-MM ZDMT-R-MM ZPMT-R-MM ZPMT-R-MR



Обозначение	Тв. сплав с покрытием						Стр.
	NCM325	PC3500	PC3300	PC3525	PC3545	PC6510	
SDMT 090308-MM		●					E14
SPMT 060304	●						E21
120408-MM		●			●		
120508-MMN							
ZDMT 080310R-MM		●					E24
110312.5R-MM		●					
130416R-MM		●					
ZPMT 160520R-MM		●					
160525R-MM		●					
160525R-MR		●					
160531.5R-MM		●					

Комплектующие



ETNA02506* TW15S** TW07P*
ETNA0408** TW20-100
ETNA0511

*BRE 20, BRE 25 **BRE 32

Рекомендуемые режимы резания

Обработка: А Пазов; А Уступов (главной р.к.); В Уступов (вспомогательной р.к.); С

Обрабатываемые материалы	Твердость	Режимы резания		Обработка
		Vr, м/мин	Sz, мм/зуб	
P	180 ~ 280HB	260(180 ~ 310)	0.125(0.10 ~ 0.15)	A
		240(160 ~ 290)	0.15(0.10 ~ 0.20)	B
	280 ~ 380HB	190(130 ~ 230)	0.10(0.05 ~ 0.15)	C
		170(120 ~ 200)	0.15(0.10 ~ 0.20)	A
	35 ~ 45HRC	170(110 ~ 190)	0.10(0.05 ~ 0.15)	B
		160(110 ~ 180)	0.10(0.05 ~ 0.15)	C
M	≤300HB	190(130 ~ 230)	0.10(0.05 ~ 0.15)	A
		170(120 ~ 200)	0.15(0.10 ~ 0.20)	B
		170(120 ~ 200)	0.10(0.05 ~ 0.15)	C
K	≤260HB	260(180 ~ 310)	0.10(0.05 ~ 0.15)	A
		240(160 ~ 290)	0.15(0.10 ~ 0.20)	B
H	Предел прочности на растяжение ≤350MPa	200(140 ~ 240)	0.10(0.05 ~ 0.15)	A
		190(130 ~ 230)	0.15(0.10 ~ 0.20)	B
		170(100 ~ 200)	0.10(0.05 ~ 0.15)	C
H	Предел прочности на растяжение 360~500MPa	150(110 ~ 180)	0.15(0.10 ~ 0.20)	A
		110(70 ~ 130)	0.10(0.05 ~ 0.15)	B
		100(60 ~ 120)	0.15(0.10 ~ 0.20)	C



Высокопроизводительные фрезы для обработки канавок под уплотнительные кольца

O-Ring Cutter *New*

- Высокая производительность обработки канавок под уплотнительные кольца
- Более высокое качество обработки, чем у аналогичных фрез из HSS
- Высокая скорость резания
- Уменьшенное время на переточку пластин, по сравнению с HSS
- Возможность изготовления специальных форм пластин

Система обозначения корпусов фрез

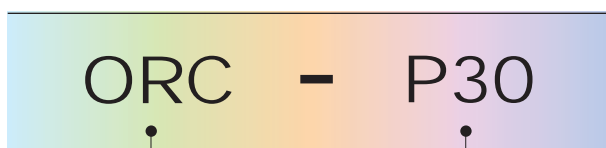

Фреза серии "O-Ring"

Размер кольца

Система обозначения пластин

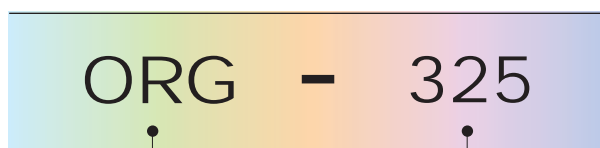

O-Ring канавки

Ширина канавки

Пластина для обработки канавок

325 : 3.25

Маршрут изготовления уплотнительных соединений

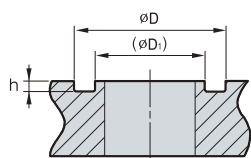

Фрезерование канавки под уплотнительное кольцо

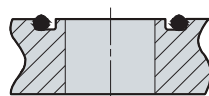

Монтаж уплотнительного кольца

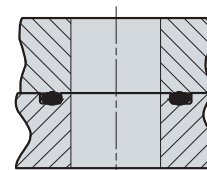

Сборка

Размер кольца	øD	(øD ₁)	h ± 0.05
P08	11.0	5.8	1.40
P09	12.0	6.8	
P10	13.0	7.8	
P11	15.0	8.5	
P12	16.0	9.5	1.80
P14	18.0	11.5	
P15	19.0	12.5	
P16	20.0	13.5	
P18	22.0	15.5	
P20	24.0	17.5	
P21	25.0	18.5	2.70
P22	26.0	19.5	
P24	30.0	20.6	
P25	31.0	21.6	

Размер кольца	øD	(øD ₁)	h ± 0.05
P26	32.0	22.6	2.70
P28	34.0	24.6	
P29	35.0	25.6	
P30	36.0	26.6	
P31	37.0	27.6	
P32	38.0	28.6	
P34	40.0	30.6	
P35	41.0	31.6	
P38	44.0	34.6	
P40	46.0	36.6	
G25	30.0	21.8	2.40
G30	35.0	26.8	
G35	40.0	31.8	
G40	45.0	36.8	

Рекомендуемые режимы резания

Обрабатываемые материалы	S _z , мм/зуб	V _p , м/мин
		Марка сплава
		PC3500
Нержавеющие стали (STS304)	0.03~0.12	60~130
Углеродистые стали (SM□□C)	0.05~0.15	80~150
легированные стали (SCM)	0.05~0.15	80~150
Закаленные стали (STD, NAK)	0.03~0.12	60~130

Пример обработки



ORC *New*

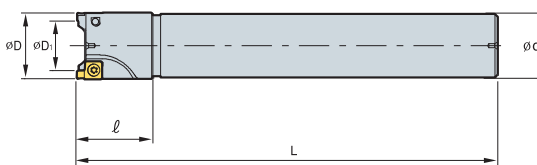

(мм)

Обозначение		øD	øD1	ød	l	L	Применяемые СМП	Марка сплава
ORC - P08	1	11.0	5.7	16	30	150	ORG265	P08
P09	1	12.0	6.7	16	30	150	ORG265	P09
P10	1	13.0	7.7	16	30	150	ORG265	P10
P11	1	15.0	8.5	16	30	150	ORG325	P11
P12	2	16.0	9.5	16	30	200	ORG325	P12
P14	2	18.0	11.5	20	30	200	ORG325	P14
P15	2	19.0	12.5	20	30	200	ORG325	P15
P16	2	20.0	13.5	20	30	200	ORG325	P16
P18	2	22.0	15.5	20	30	200	ORG325	P18
P20	2	24.0	17.5	25	30	200	ORG325	P20
P21	2	25.0	18.5	25	30	200	ORG325	P21
P22	2	26.0	19.5	25	30	200	ORG325	P22
P24	2	30.0	20.6	32	40	250	ORG470	P24
P25	2	31.0	21.6	32	40	250	ORG470	P25
P26	2	32.0	22.6	32	40	250	ORG470	P26
P28	2	34.0	24.6	32	40	250	ORG470	P28
P29	2	35.0	25.6	32	40	250	ORG470	P29
P30	2	36.0	26.6	32	40	250	ORG470	P30
P31	2	37.0	27.6	32	40	250	ORG470	P31
P32	2	38.0	28.6	32	40	250	ORG470	P32
P34	2	40.0	30.6	42	40	250	ORG470	P34
P35	2	41.0	31.6	42	40	250	ORG470	P35
P38	2	44.0	34.6	42	40	250	ORG470	P38
P40	2	46.0	36.6	42	40	250	ORG470	P40
ORC - G25	2	30.0	21.9	32	40	250	ORG405	G25
G30	2	35.0	26.9	32	40	250	ORG405	G30
G35	2	40.0	31.9	42	40	250	ORG405	G35
G40	2	45.0	36.9	42	40	250	ORG405	G40

Применяемые СМП

ORG



Cutter Обозначение	Обозначение	Тв. сплав с покрытием								Кермет			Тв. сплав				Стр.	
		NCM325	NCM335	NC5330	PC3500	PC3600	PC3545	PC9530	PC6510	PC215K	PD2000	CN2000	CN20	CN30	H01	G10		ST30A
ORC-P08~P10	ORG 265				●													
ORC-P11~P22	325				●													
ORC-P24~P40	470				●													
ORC-G25~G40	405				●													

Комплектующие



ORC-P08~P22	FTKA0307	TW09S
ORC-P24~P40	FTGA03508	TW15S
ORC-G25~G40		

Применяемые СМП смотреть на стр. E12

● : Наличие на складе

Высокая эффективность обработки фасок

Chamfer Tool

- Высокая эффективность обработки фасок
- Фаски с углами: 15°, 30°, 45°, 60°.
- Большая длина режущей кромки позволяет обрабатывать широкие фаски.



Фрезы для прямых и обратных фасок



Зенковки

Система обозначения фрез

CE	45	-	11	25	R	-	S	20
Концевая фасочная фреза	Угол фаски 45°		Применяемые СМП 11 : SPMT110408-KC 12 : SPMN120308 31 : XCET310404ER-KC	Минимальный диаметр обработки Ø25	Исполнение R : Правое L : Левое		Тип хвостовика S : Стандартный M : Удлиненный L : Длинный	Диаметр хвостовика Ø20

Рекомендуемые режимы резания

Обрабатываемые материалы	Марка сплава	ØD(Ø5 ~Ø20)		ØD(Ø25 ~Ø35)	
		Vp, м/мин	Sz, мм/зуб	Vp, м/мин	Sz, мм/зуб
P	PC3500 PC5300 ST30A	100~160	0.05-0.25	100~160	0.05~0.25
M	PC5300 PC3545	90~120	0.05-0.20	90~120	0.10~0.30
K	PC5300 G10	100~160	0.10~0.30	100~160	0.30~0.50

Типовые схемы применения фрез

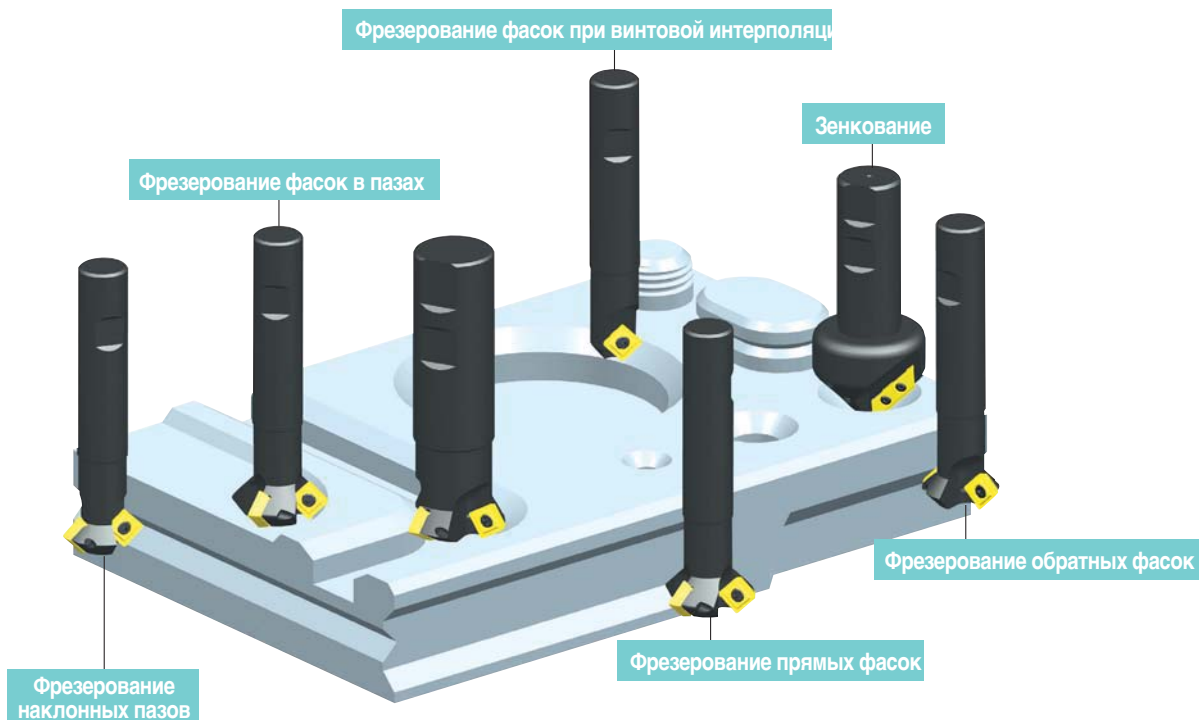

Фасочно;центровочные фрезы

Система обозначения фрез

CE	45	- 16	00	R - S	20	
Фасочная фреза	Угол фаски 45°	Радиус вписанной окружности СМП 16 : TWX16R-KC 22 : TWX22R-KC	Минимальный диаметр обработки Ø0	Исполнение R : Правое L : Левое	Длина фрезы S : 90,110 L : 200	Диаметр хвостовика Ø12 Ø20 Ø25

Назначение и рекомендуемые режимы резания

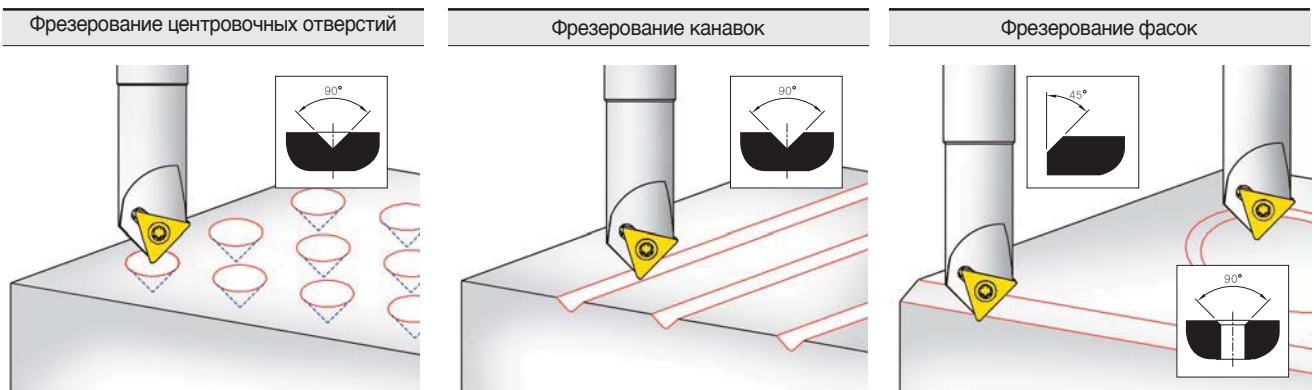

Обрабатываемые материалы	Твердость (HRC)	Фрезерование центровочных отверстий, канавок		Фрезерование фасок	
		Vp, м/мин	Sz, мм/зуб	Vp, м/мин	Sz, мм/зуб
Штамповые, углеродистые, легированные стали	Ниже HRC 30	80 ~ 200	0.01 ~ 0.04	100 ~ 250	0.04 ~ 0.06
Высокоуглеродистые легированные стали	HRC 30~40	150 ~ 250	0.02 ~ 0.06	150 ~ 300	0.05 ~ 0.10
Алюминиевые и медные сплавы	-	150 ~ 300	0.04 ~ 0.08	150 ~ 350	0.05 ~ 0.10
Нержавеющие стали	-	80 ~ 150	0.02 ~ 0.06	100 ~ 250	0.05 ~ 0.10
Нержавеющие стали	-	60 ~ 120	0.01 ~ 0.03	60 ~ 150	0.03 ~ 0.06
Жаропрочные стали	-	60 ~ 80	0.01 ~ 0.03	60 ~ 100	0.03 ~ 0.06

Примечание: при неправильном выборе Sz возможно выкрашивание и поломка СМП

Типовые примеры применения фрез



Цельные фасочные фрезы *New*







Система обозначения фрез

CCT	090	T	-	080	L
● Тип	● Угол фаски	● Исполнение		● Диаметр	● Длина
CCT : Центрование, обработка фасок CET : Центрование, обработка фасок, концевое фрезерование	060 : 60° 090 : 90° 120 : 120°	Нет : Одностороннее Т : Двухстороннее		080 : Ø8,0	Нет : стандартная L : Двухстороннее

Общие характеристики

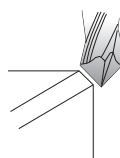
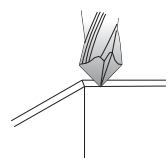
CET(Центрование, обработка фасок, концевое фрезерование)	CCT(Центрование, обработка фасок)
  <ul style="list-style-type: none"> ▶ Внутренняя обработка фасок стороной до 0,5мм ▶ Фрезерование цилиндрической частью (аналогия с концевым фрезерованием) ▶ Возможность переточки 	  <ul style="list-style-type: none"> ▶ Специальная заточка режущей кромки, повышающая прочность ▶ Низкие силы резания

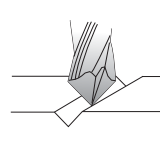
СЕТ / ССТ Типовые схемы применения фрез

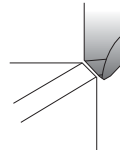
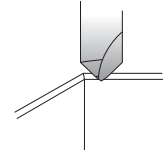
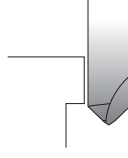
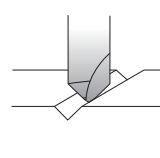
	Центрование отверстий	Зенкование	Обработка наружных фасок	Обработка внутренних фасок	Фрезерование контуров	Фрезерование пазов
Серия (CET)						
60°	×	●	●	● ~ ▲	●	×
90°	▲	●	●	●	●	● ~ ▲
120°	●	●	●	●	●	●
Серия (CCT)						
60°	●	●	● ~ ▲	▲ ~ ×	×	×
90°	●	●	● ~ ▲	▲ ~ ×	×	×
120°	●	●	●	●	×	●



СЕ (обработка прямых и обратных фасок)



Рис. 1



Рис. 2

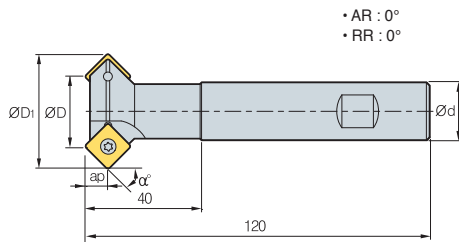

(мм)

Обозначение	ØD	ØD ₁	Ød	ap	Рис.	Применяемые СМП	α° (Угол фаски)		Диапазон диаметров (Min-Max)	Обработка
							прямой	обратный		
CE 15-1125R-S20	2	25	30.5	20	9.5	SPMT110408 - KC	15°	-	Ø25~Ø30	Прямых фасок
	2	25	35.5	20	8.5		30°	60°	Ø25~Ø35	Прямых и обратных фасок
	1	7	21.9	20	7.0		45°	-	Ø7~Ø21	Прямых фасок
	2	19	33.9	20	7.0		45°	45°	Ø19~Ø33	Прямых и обратных фасок
	3	25	39.9	20	7.0		45°	45°	Ø25~Ø39	Прямых и обратных фасок
	3	25	43.3	32	5.0		60°	30°	Ø25~Ø42	Прямых и обратных фасок
CE 45-1207R-S32	1	7	23.3	32	7.8	SPMN120308	45°	-	Ø7~Ø22	Прямых фасок
	2	20	37.3	32	7.8		45°	-	Ø21~Ø36	Прямых фасок
	2	25	42.3	32	7.8		45°	-	Ø26~Ø41	Прямых фасок
	2	35	52.3	32	7.8		45°	-	Ø36~Ø51	Прямых фасок

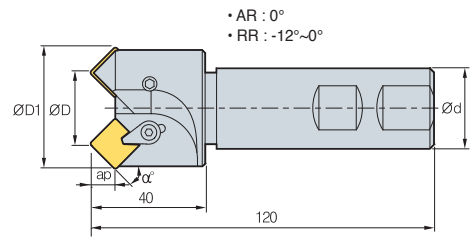
Применяемые СМП

SPMT-KC



SPMN

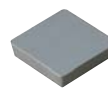

Обозначение	Тв. сплав с покрытием									Кермет			Тв. сплав				Стр.
	NCM325	NCM335	NC5330	PC3500	PC5300	PC3545	PC9530	PC6510	PC215K	PD2000	CN2000	CN20	CN30	H01	G10	ST30A	
SPMT 110408-KC				●											●	●	
SPMN 120308																●	

Комплектующие



CE□□-11□□R-S	FTKA0408	-	-	TW15S	-
CE□□-12□□R-S	CHX0617L	CH6R2	CR05	-	HW30L

Применяемые СМП смотреть на стр. E21

● : Наличие на складе

CE (Фасочно-центровочная фреза)

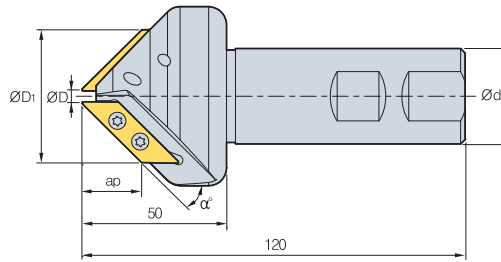

- AR : $-5^{\circ} \sim 1^{\circ}$
- RR : 0°

(мм)

Обозначение		$\varnothing D$	$\varnothing D_1$	$\varnothing d$	ap	α° (Угол фаски)	Диапазон диаметров (Min-Max)	Обработка
CE 30-3105R-S32	1	5	35	32	26	30°	$\varnothing 5 \sim \varnothing 35$	Прямых фасок
45-3105R-S32	2	5	48	32	21	45°	$\varnothing 5 \sim \varnothing 48$	Прямых фасок
60-3105R-S32	2	5	57	32	15	60°	$\varnothing 5 \sim \varnothing 57$	Прямых фасок

Применяемые СМП

XCET-KC



Обозначение	Тв. сплав с покрытием									Кермет			Тв. сплав				Стр.	
	NCM325	NCM335	NC5330	PC3500	PC5300	PC3545	PC9530	PC6510	PC215K	PD2000	CN2000	CN20	CN30	H01	G10	ST30A		ST20
XCET 310404ER-KC				●											●	●		E23

Комплектующие



CE□□-31□□R-S

FTKA03510

TW15S



СЕ (Фасочно-центровочная фреза)



Рис. 1



Рис. 2

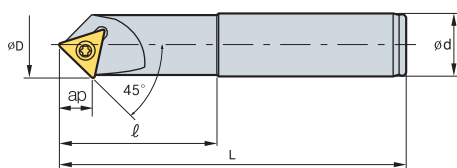

- AR : $-12^\circ \sim 15^\circ$
- RR : 0°

(мм)

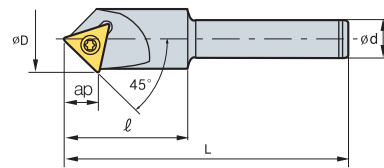
Обозначение	$\varnothing D$	$\varnothing d$	ℓ	L	ap	Рис.	Применяемые СМП	Диапазон диаметров (Min-Max)	Обработка
CE 45-1600R-S12	22	12	40	90	10	2	TWX16R-KC	$\varnothing 0 \sim \varnothing 20$	Фрезерование центровочных отверстий
45-1600R-S20	22	20	50	110	10	1	TWX16R-KC	$\varnothing 0 \sim \varnothing 20$	
45-1600R-L20	22	20	60	200	10	1	TWX16R-KC	$\varnothing 0 \sim \varnothing 20$	
45-2200R-S12	29	12	40	90	14	2	TWX22R-KC	$\varnothing 0 \sim \varnothing 27$	Фрезерование канавок
45-2200R-S25	29	25	50	110	14	1	TWX22R-KC	$\varnothing 0 \sim \varnothing 27$	Фрезерование фасок
45-2200R-L25	29	25	60	200	14	1	TWX22R-KC	$\varnothing 0 \sim \varnothing 27$	

Применяемые СМП

TWX-KC



Обозначение	Тв. сплав с покрытием										Кермет			Тв. сплав				Стр.
	NCM325	NCM335	NC5330	PC3500	PC5300	PC3545	PC9530	PC6510	PC215K	PD2000	CN2000	CN20	CN30	H01	G10	ST30A	ST20	
TWX 16R-KC				●														
22R-KC				●														

Комплектующие



CE45-□□□□R-□□

FTNA0408

TW15L

CET *New*

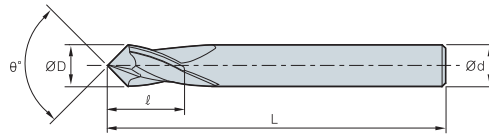

						(мм)
Обозначение		$\varnothing D$	$\varnothing d$	l	L	θ°
CET060 -	030	3	3	5.5	50	60°
	040	4	4	7	50	
	060	6	6	10	60	
	080	8	8	13	70	
	100	10	10	16	70	
	120	12	12	18	80	
	160	16	16	24	100	
CET090 -	030	3	3	5.5	50	90°
	040	4	4	7	50	
	060	6	6	10	60	
	080	8	8	13	70	
	100	10	10	16	70	
	120	12	12	18	80	
	160	16	16	24	100	
CET120 -	030	3	3	5.5	50	120°
	040	4	4	7	50	
	060	6	6	10	60	
	080	8	8	13	70	
	100	10	10	16	70	
	120	12	12	18	80	
	160	16	16	24	100	



ССТ *New*



Рис. 1



Рис. 2

					(мм)	
Обозначение	$\varnothing D = \varnothing d$	$\varnothing D_1$	L	θ°	Рис.	
ССТ060 -	030	3	1.0	60°	1	
	040	4	1.5			
	060	6	2.0			
	080	8	2.5			
	100	10	3.0			
	120	12	4.0			
	160	16	5.0			
ССТ060Т -	030	3	1.0		60°	2
	040	4	1.5			
	060	6	2.0			
	080	8	2.5			
	100	10	3.0			
	120	12	4.0			
	160	16	5.0			
ССТ060Т -	030L	3	1.0	90°		1
	040L	4	1.5			
	060L	6	2.0			
	080L	8	2.5			
	100L	10	3.0			
	120L	12	4.0			
	160L	16	5.0			
ССТ090 -	030	3	1.0		90°	1
	040	4	1.5			
	060	6	2.0			
	080	8	2.5			
	100	10	3.0			
	120	12	4.0			
	160	16	5.0			
ССТ090Т -	030	3	1.0	90°		2
	040	4	1.5			
	060	6	2.0			
	080	8	2.5			
	100	10	3.0			
	120	12	4.0			
	160	16	5.0			
ССТ090Т -	030L	3	1.0		120°	1
	040L	4	1.5			
	060L	6	2.0			
	080L	8	2.5			
	100L	10	3.0			
	120L	12	4.0			
	160L	16	5.0			
ССТ120 -	030	3	1.0	120°		1
	040	4	1.5			
	060	6	2.0			
	080	8	2.5			
	100	10	3.0			
	120	12	4.0			
	160	16	5.0			
ССТ120Т -	030	3	1.0		120°	2
	040	4	1.5			
	060	6	2.0			
	080	8	2.5			
	100	10	3.0			
	120	12	4.0			
	160	16	5.0			
ССТ120Т -	030L	3	1.0	120°		1
	040L	4	1.5			
	060L	6	2.0			
	080L	8	2.5			
	100L	10	3.0			
	120L	12	4.0			
	160L	16	5.0			

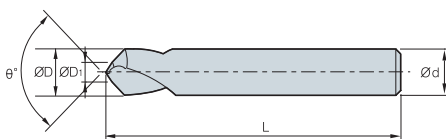

TFE

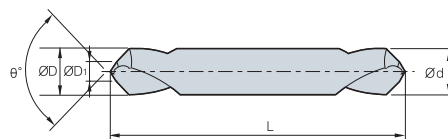
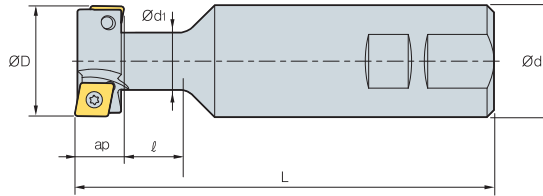

AA
90°

• AR : 5°
• RR : -5°

Обозначение			$\varnothing D$	$\varnothing d$	$\varnothing d_1$	ℓ	L	a_p	Применяемые СМП
TFE	2125R/L	2	21	25	10.5	20	109	9	CPMT06
	2525R/L	2	25	25	12.5	21	112	11	CPMT08
	3232R/L	2	32	32	16.5	26	120	14	CPMT09
	4032R/L	2	40	32	20.5	32	130	18	CPMH12
	5032R/L	4	50	32	26.5	38	140	22	CPMH12

(мм)

Применяемые СМП

CPMT

CPMH

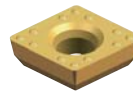
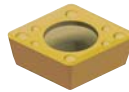

Обозначение	Тв. сплав с покрытием										Кермет			Тв. сплав				Стр.
	NCM325	NCM335	NC5330	PC3500	PC5300	PC3545	PC9530	PC6510	PC215K	PD2000	CN2000	CN20	CN30	H01	G10	ST30A	ST20	
CPMT 060204-MM				●														
080308-MM				●														
09T308-MM				●														
CPMH 120408-MM				●														

Комплектующие



Винт



Ключ

2125R/L	FTNA02555	TW08S
2525R/L	FTNA0306	TW09S
3232R/L	FTNA0407	TW15S
4032R/L	PTMA0511A	TW15S
5032R/L		

Схема сборки

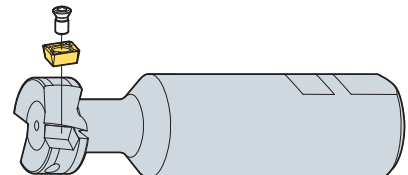

Применяемые СМП смотреть на стр. E07

● : Наличие на складе



Новые фрезы со сменными пластинами для высококачественной обработки заготовок

Pro-L Mill *New*

- Улучшенная перпендикулярность и низкие силы резания достигаются путем сочетания задней поверхности и высокого угла подъема режущей кромки.
- Повышение производительности более чем в полтора раза за счет большей глубины резания по сравнению с существующим продуктом
- Жесткая конструкция зажима путем применения двух винтов
- Улучшенный отвод стружки благодаря спиральной конструкции карманов и применения системы охлаждения



Обработка

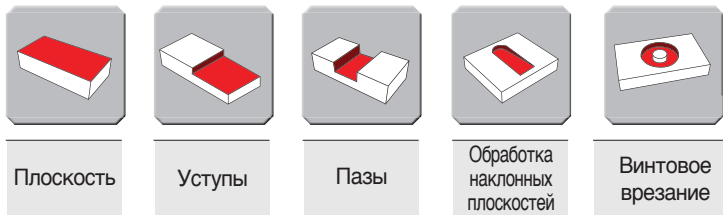

Свойства



Обозначение концевой фрезы



PAL	S	050	H	R - 3	S	40	
Pro-L Mill	Тип инструмента	Диаметр инструмента.	Тип охлаждения	направление	Число зубьев	Длина инструмента	Диаметр хвостовика
	S: хвостовика	050 : Ø50	Не отмечено: Нет H: Внутренний подвод	R: Правый L: Левый	3 : 3 зубьев	S: Стандартный тип M: Средний тип L: Длинный тип	40 : Ø40

Обозначение торцевой фрезы

PAL	C	M	063	H	R
Pro-L Mill	Тип инструмента	Единица измерений	Диаметр инструмента.	Тип охлаждения	направление
	C: Фрезы	M: Метрический тип	063 : Ø63	Не отмечено: Нет H: Внутренний подвод	R: Правый M: С несколькими режущими кромками



Стружколомов

СМП		Режущая кромка	Общие характеристики	
Al	MA			Специально оптимизированная режущая кромка для обработки алюминия и полированная поверхность обеспечивает превосходное качество обработки
Труднообрабатываемый материал	ML			Конструкция стружколома с низким сопротивлением резанию обеспечивает отличное качество при чистовой обработке и обработки труднообрабатываемых материалов

Выбор сплава и стружколома

Категория	M (Нержавеющие стали)	N (алюминиевых сплавов)	S (Жаропрочные стали)
Сплав	PC5300 / PC5400	H01	PC5300 / PC5400
MA	—	○	—
ML	○	—	○

Примеры обработки

N Al6061 (HRC30)

- Режимы резания
 - $V_p = 500 \text{ м/мин}$
 - $S_z = 0.2 \text{ мм/зуб}$
 - $t = 30 \sim 60 \text{ мм}$
 - $B = 1 \sim 5 \text{ мм}$ (чистовой обработки : 1 мм, черновая обработка : 5 мм)
 - $z = 3$



Pro-L Mill Нарезание и Винтовая резки технические

1. Тангенциальное врезание

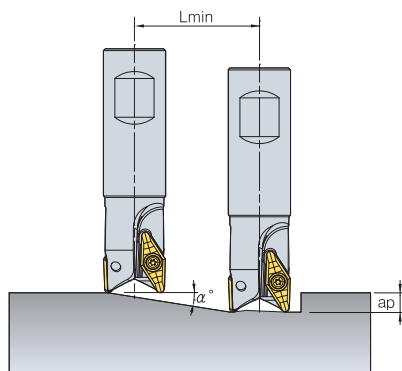

2. Винтовое врезание (интерполяция для глухих отверстий с плоским дном или сквозных отверстий*)

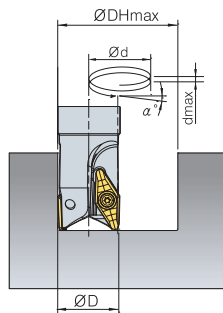

3. Винтовое врезание для сквозных отверстий**

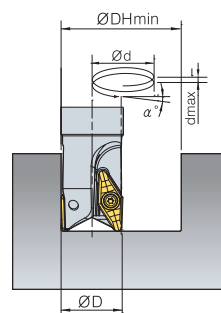

Обозначение	ØD(мм)	Тангенциальное врезание		Винтовое врезание для глухих отверстий				Винтовое врезание для сквозных отверстий	
		α°(max)	Lmin(мм)	ØDHmax (мм)	dmax (мм)	ØDHmin (мм)	dmax (мм)	ØDHmin (мм)	dmax (мм)
PALS032HR-2S20	32	3.37	170	62	3.6	60	3.5	55	3.2
PALS032HR-2S25	32	3.37	170	62	3.6	60	3.5	55	3.2
PALS032HR-2S32	32	3.37	170	62	3.6	60	3.5	55	3.2
PALS040HR-2S32	40	2.12	270	78	2.9	76	2.8	71	2.6
PALS040HR-2S40	40	2.12	270	78	2.9	76	2.8	71	2.6
PALS040HR-2S42	40	2.12	270	78	2.9	76	2.8	71	2.6
PALS040HR-3S32	40	2.12	270	78	2.9	76	2.8	71	2.6
PALS040HR-3S40	40	2.12	270	78	2.9	76	2.8	71	2.6
PALS040HR-3S42	40	2.12	270	78	2.9	76	2.8	71	2.6
PALS050HR-3S32	50	2.08	275	98	3.6	96	3.5	91	3.3
PALS050HR-3S40	50	2.08	275	98	3.6	96	3.5	91	3.3
PALS050HR-3S42	50	2.08	275	98	3.6	96	3.5	91	3.3
PALS063HR-4S32	63	1.76	325	124	3.8	122	3.8	117	3.6
PALS063HR-4S40	63	1.76	325	124	3.8	122	3.8	117	3.6
PALS063HR-4S42	63	1.76	325	124	3.8	122	3.8	117	3.6
PALS063HM-4S32	63	1.76	325	124	3.8	122	3.8	117	3.6
PALS063HM-4S40	63	1.76	325	124	3.8	122	3.8	117	3.6
PALS063HM-4S42	63	1.76	325	124	3.8	122	3.8	117	3.6
PALCM063HR	63	1.76	325	124	3.8	122	3.8	117	3.6

• Lmin : Если t=10 мм

• Lmin : Минимальная длина врезания

α° : Максимальный угол врезания

ap : Глубина резания

$$L_{min} = \frac{ap}{\tan \alpha} \text{ (мм)}$$



PALC(M) *New*

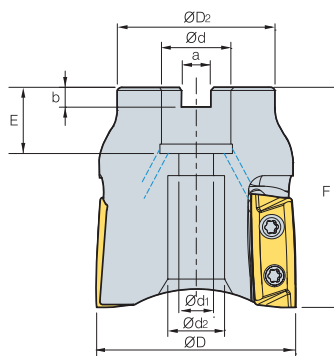

AA
90°
• AR : 16°
• RR : -8°

Обозначение		$\varnothing D$	$\varnothing D_2$	$\varnothing d$	$\varnothing d_1$	$\varnothing d_2$	$\varnothing d_3$	a	b	E	E_1	F	ap	
PALC(M) 063HR	4	63	50	22	11	18	-	10	6.3	21	28	70	34	0.57

Применяемые СМП

LXET



Тип	Обозначение	Тв. сплав с покрытием									Кермет			Тв. сплав			Стр.	
		NCM325	NCM335	NC5330	PC3500	PC5300	PC5400	PC3545	PC9530	PC6510	PC215K	CN2000	CN20	CN30	H01	G10		ST30A
Ø63	LXET 3405PEFR-63-MA																	
	LXET 3405PEER-63-ML																	
																		E10

Применяемые оправки

Обозначение	$\varnothing d$	Применяемые оправки
PALC(M) 063HR	22	BT□□-FMC22-□□

Комплектующие



Ø63

FTGA0511-P

TW20-100

Применяемые СМП смотреть на стр. E10

● : Наличие на складе



PALS (Нормальная длина рабочей части) *New*

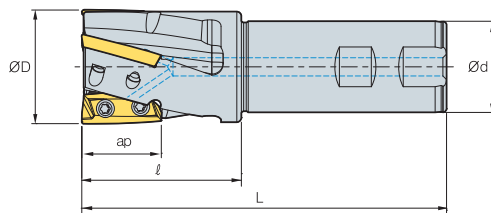

• AR: 12°~16°
• RR: -5°~9°

Обозначение			ØD	ød	l	L	ap	
PALS	032HR-2S20	2	32	20	50	140	25	0.36
	032HR-2S25	2	32	25	50	140	25	0.48
	032HR-2S32	2	32	32	50	140	25	0.71
	040HR-2S32	2	40	32	50	140	25	0.85
	040HR-2S40	2	40	40	50	140	25	1.16
	040HR-2S42	2	40	42	50	140	25	1.26
	040HR-3S32	3	40	32	50	140	25	0.80
	040HR-3S40	3	40	40	50	140	25	1.10
	040HR-3S42	3	40	42	50	140	25	1.20
	050HR-3S32	3	50	32	70	160	34	1.10
	050HR-3S40	3	50	40	70	160	34	1.40
	050HR-3S42	3	50	42	70	160	34	1.50
	063HR-4S32	4	63	32	70	160	34	1.60
	063HR-4S40	4	63	40	70	160	34	1.92
063HR-4S42	4	63	42	70	160	34	2.00	

Применяемые СМП

LXET



Тип	Обозначение	Тв. сплав с покрытием									Кермет			Тв. сплав				Стр.	
		NCM825	NCM835	NC5330	PC3500	PC6300	PC5400	PC3545	PC9530	PC6510	PC215K	CN2000	CN20	CN30	H01	G10	ST30A		ST20
Ø32	LXET 2504PEFR-32-MA																		E10
	2504PEER-32-ML																		
Ø40	2504PEFR-40-MA																		
	2504PEER-40-ML																		
Ø50	3405PEFR-50-MA																		
	3405PEER-50-ML																		
Ø63	3405PEFR-63-MA																		
	3405PEER-63-ML																		

Комплектующие



Ø32	FTKA0408	TW15S	-
Ø40	FTKA0410	TW15S	-
Ø50	FTGA0510-P	-	TW20-100
Ø63	FTGA0511-P	-	TW20-100

PALS (Удлиненная рабочая часть) *New*

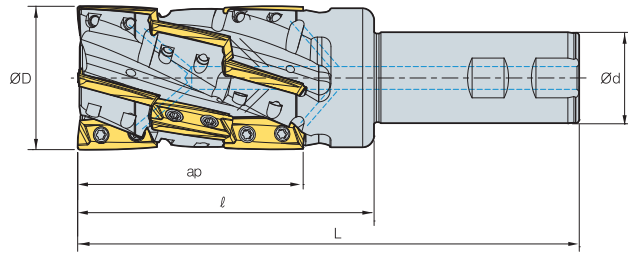

AA
90°
• AR : 16°
• RR : -8°

(мм)

Обозначение		$\varnothing D$	$\varnothing d$	ℓ	L	ap	
PALS	063HM-4S32	4	63	32	70	160	1.60
	063HM-4S40	4	63	40	70	160	1.92
	063HM-4S42	4	63	42	70	160	2.00

Применяемые СМП

LXET



Тип	Обозначение	Тв. сплав с покрытием										Кермет			Тв. сплав				Стр.
		NCM325	NCM335	NC5330	PC3500	PC5300	PC5400	PC3545	PC9530	PC6510	PC215K	CN2000	CN20	CN30	H01	G10	ST30A	ST20	
Ø63	LXET 3405PEFR-63-MA 3405PEER-63-ML																		E10

Комплектующие



Ø63

FTGA0511-P

TW20-100



Полированная передняя поверхность СМП уменьшает вероятность наростообразования и улучшает отвод стружки из зоны резания.

Pro-A mill

- Полированная передняя поверхность СМП уменьшает вероятность наростообразования и улучшает отвод стружки из зоны резания.
- Возможность применения сменных фрезерных головок малого диаметра.
- Широкий выбор сменных фрезерных головок.
- Высокая эффективность обработки уступов, фасонных и наклонных поверхностей.
- Улучшенный отвод стружки при обработке глубоких пазов благодаря внутренней системе подвода СОЖ.



Обработка



Контурная обработка

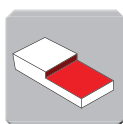

Обработка уступов, пазов



Тангенциальное врезание



Внутренний подвод СОЖ

Модификации фрез

Тип	Серия	Pro-A mill	Система подвода СОЖ	
Применение малогабаритный алюминиевый обработка	Pro-A 2000		<ul style="list-style-type: none"> • Сменная фрезерная головка : $\varnothing 12\sim\varnothing 42$ • Концевая фреза : $\varnothing 12\sim\varnothing 42$ • СМП : VDKT11T210N-MA VDKT11T220N-MA 	○
общий применение алюминиевый обработка	Pro-A 4000		<ul style="list-style-type: none"> • Торцевая фреза : $\varnothing 40\sim\varnothing 100$ • Концевая фреза : $\varnothing 32\sim\varnothing 40$ • СМП : VCKT220530N-MA 	○

Рекомендуемые режимы резания

Обрабатываемые материалы		Скорость резания, м/мин
Алюминиевые сплавы	Rm < 280 MPa	1000
	Rm > 280 MPa	800
Медные сплавы	Long chip	250
Термопластик	-	300
Алюминиевые сплавы	Si < 12%	800
Медные сплавы	Сегментная стружка	400
Магниеые сплавы	-	400
Акрил	-	150



Выбор оптимальных параметров при фрезеровании с врезанием

1. Тангенциальное врезание

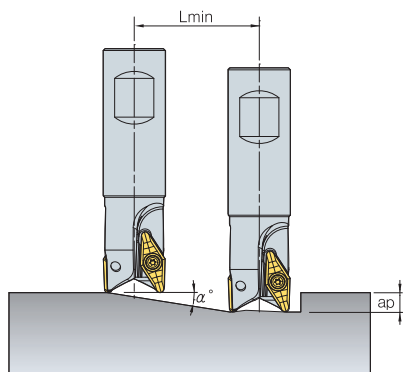

2. Винтовое врезание (интерполяция для глухих отверстий с плоским дном или сквозных отверстий*)

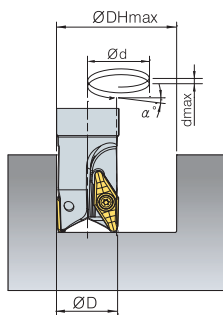

3. Винтовое врезание для сквозных отверстий**

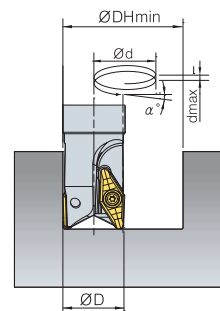

Обозначение	ØD(мм)	Тангенциальное врезание		Винтовое врезание для глухих отверстий				Винтовое врезание для сквозных отверстий	
		α°(max)	Lmin(мм)	ØDHmax(мм)	dmax(мм)	ØDHmin(мм)	dmax(мм)	ØDHmin(мм)	dmax(мм)
PAS2012HR	12	11.9	38	23	4.8	21	4.4	19	4.0
PAS2016HR	16	12.5	36	31	6.9	29	6.4	27	6.0
PAS2020HR	20	9.7	47	39	6.7	37	6.3	35	6.0
PAS2025HR	25	7.6	60	49	6.5	47	6.3	45	6.0
PAS2032HR	32	5.8	79	63	6.4	61	6.2	59	6.0
PAS2042HR	42	4.3	105	83	6.3	81	6.2	79	6.0
PAS4032HR	32	24.4	22	59	26.8	54	24.5	40	18.2
PAS4040HR	40	18.4	30	75	25.0	70	23.3	56	18.7
PAS4050HR	50	14.0	40	95	23.8	90	22.5	76	19.0
PAS4063HR	63	10.7	53	121	22.8	116	21.9	102	19.2
PAC(M)4080HR	80	8.1	70	155	22.1	150	21.4	136	19.4
PAC(M)4100HR	100	6.3	90	195	21.7	190	21.1	176	19.6

• Lmin : Если t=8 мм

• Lmin : Минимальная длина врезания

α° : Максимальный угол врезания

ap : Глубина резания

$$Lmin = \frac{ap}{\tan \alpha^\circ} \text{ (мм)}$$



Стабильный стружкоотвод и уменьшение вероятности наростообразования и налипания стружки на переднюю поверхность.

Pro-X Mill

- Стабильный стружкоотвод и уменьшение вероятности наростообразования и налипания стружки на переднюю поверхность.
- Большой главный передний угол обеспечивает снижение сил резания и высокое качество чистовой обработки.
- Высокая эффективность при высокоскоростной обработке алюминия.
- Высокая эффективность при обработке ступенчатых и фасонных поверхностей.



Система зажима СМП

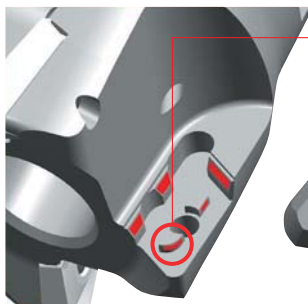

Высокая жесткость позиционирования и уменьшение вероятности налипания стружки на переднюю поверхность. Высокая эффективность при высокоскоростной обработке.

Положительная геометрия передней поверхности

Широкий выбор СМП с различными радиусами при вершине (R 0.4 ~ R 5.0)

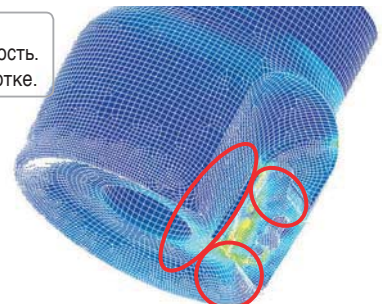

Расчет геометрии на основе метода конечных элементов (МКЭ) (анализ распределения нагрузки при резании) Жесткость фиксирования СМП. •Strong Кронштейнинг of insert

График изменения центробежной силы от частоты вращения фрезы

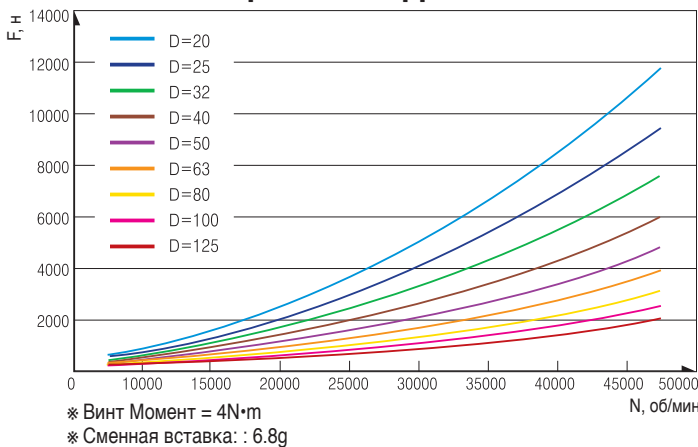

Маркировка
Обозначение, максимальная частота вращения n, об/мин



Максимальная частота вращения для различных диаметров фрез

Диаметр фрезы D мм		Максимальная частота вращения	
5000 Тип	6000 Тип	n (min⁻¹)	Vp, м/мин
20	-	15,000	940
25	25	32,600	2,559
32	32	28,800	2,894
40	40	25,800	3,240
50	50	23,000	3,611
63	63	20,500	4,055
80	80	18,200	4,572
100	100	16,300	5,118
125	125	14,600	5,731

Рекомендуемые режимы резания

Обрабатываемые материалы	Скорость резания V, м/мин	Подача S, мм/зуб
Алюминий, алюминиевые сплавы	Rm280 < MPa	1200
	Rm280 > MPa	1000
Медь	сливная стружка	400
	-	350
Термопластик	-	0.20
	-	0.15
Алюминий, алюминиевые сплавы	Si <12%	1000
	Si ≥12%	-
Медные сплавы	КОРОТКИЕ стружка	500
Магниеые сплавы	-	0.20
Пластик	-	0.15

* График представляет собой значения центробежной силы действующей на СМП в условиях без нагрузки. Однако, случайная поломка СМП может произойти при частоте вращения не превышающей рекомендации установленные графиком. Во избежании несчастных случаев и травм советуем использовать защитные экраны.



Выбор оптимальных параметров при фрезеровании с врезанием

1. Тангенциальное врезание

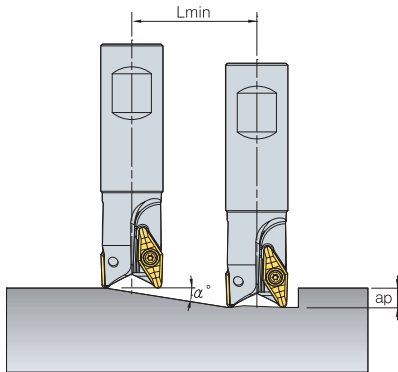

2. Винтовое врезание (интерполяция для глухих отверстий с плоским дном или сквозных отверстий*)

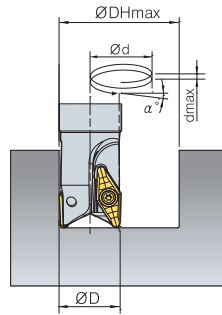

3. Винтовое врезание для сквозных отверстий**

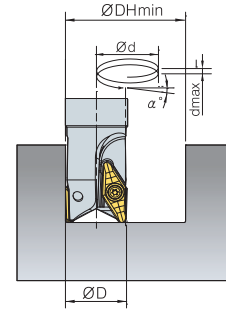

Обозначение	ØD(мм)	Тангенциальное врезание		Винтовое врезание для глухих отверстий				Винтовое врезание для сквозных отверстий	
		α°(max)	Lmin(мм)	ØDHmax(мм)	dmax(мм)	ØDHmin(мм)	dmax(мм)	ØDHmin(мм)	dmax(мм)
PAXS5020HR	20	8.4	68	34	5.0	32	4.7	27	4.0
PAXS5025HR	25	13.2	43	44	10.4	42	9.9	34	8.0
PAXS5032HR	32	9.5	60	58	9.7	56	9.3	48	8.0
PAXS5040HR	40	7.1	80	74	9.3	72	9.0	64	8.0
PAXCM5050HR	50	5.4	105	94	9.0	92	8.8	84	8.0
PAXCM5063HR	63	4.2	138	120	8.7	118	8.6	110	8.0
PAXC(M)5080HR	80	3.2	180	154	8.6	152	8.4	144	8.0
PAXC(M)5100HR	100	2.5	230	194	8.4	192	8.3	184	8.0
PAXC(M)5125HR	125	2.0	293	244	8.3	242	8.3	234	8.0
PAXS6025HR	25	9.0	63	44	6.9	42	6.6	38	6.0
PAXS6032HR	32	6.6	87	58	6.7	56	6.5	52	6.0
PAXS6040HR	40	12.1	47	74	15.9	72	15.4	56	12.0
PAXCM6060HR	50	9.0	63	94	14.8	92	14.5	76	12.0
PAXCM6063HR	63	6.7	85	120	14.1	118	13.9	102	12.0
PAXC(M)6080HR	80	5.0	113	154	13.6	152	13.4	136	12.0
PAXC(M)6100HR	100	3.9	147	194	13.2	192	13.1	176	12.0
PAXC(M)6125HR	125	3.0	188	244	13.0	242	12.8	226	12.0

Lmin : Если t=10мм

Lmin : Минимальная длина врезания

α° : Максимальный угол врезания

ap : Глубина резания

$$Lmin = \frac{ap}{\tan \alpha^\circ} \text{ (м мм)}$$

Осевое врезание, обработка пазов

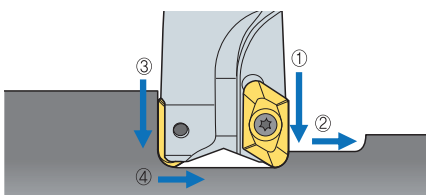

1. Технология обработки пазы (уступа):

① → ② → ③ → ④

2. При осевом врезании необходимо понизить скорость резания и подачу на 30% 50%.

Режимы резания

Диаметр фрезы	t (мм)	
	5000 Тип	6000 Тип
Ø20	8	-
Ø25	4	11
Ø32	4	6
Ø40~125	4	6

СМП	t (мм)
ХЕТК19	4
ХЕТК25	6

Обработка



Контуры



Винтовые поверхности

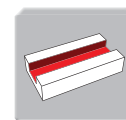

Пазы, уступы



Наклонные плоскости



РАС(M)4000

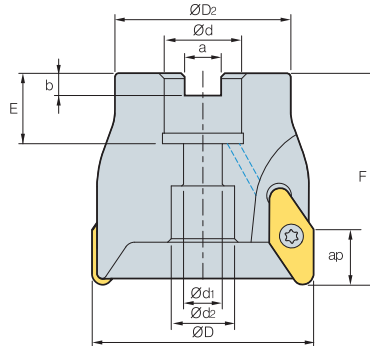

Обозначение			ØD	ØD ₂	Ød	Ød ₁	Ød ₂	a	b	E	F	ap	
РАС(M)	4040HR	3	40	32	16	9	11.5	8.4	5.6	20	55	15	0.2
	4050HR	3	50	40	22	11	18	10.4	6.3	20	55	15	0.3
	4063HR	4	63	50	22	11	18	10.4	6.3	20	60	15	0.6
	4080HR	4	80	60	25.4(27)	14	20	9.5(12.4)	6.0(7.0)	25(25)	60	15	1.0
	4100HR	5	100	80	31.75(32)	- (18)	44(26)	12.7(14.4)	8.0	37(26)	60	15	1.6

() Метрическая система

Применяемые СМП

VCKT-MA



Обозначение	Тв. сплав с покрытием								Кермет			Тв. сплав				Стр.		
	NCM325	NCM335	NC5330	PC3500	PC5300	PC3545	PC9530	PC6510	PC215K	PD2000	CN2000	CN20	CN30	H01	G10		ST30A	ST20
VCKT 220530N-MA														●				E23

Применяемые оправки

Обозначение	Ød	Применяемые оправки
РАС(M) 4040HR	16	BT □□ -FMC16- □□
	22	BT □□ -FMC22- □□
		25.4
4080HR	27	BT □□ -FMC27- □□
	31.75	BT □□ -FMA31.75- □□
4100HR	32	BT □□ -FMC32- □□

Комплектующие



FTNC04509 (Ø40)
FTNC04511

TW 20S

PAS2000/4000

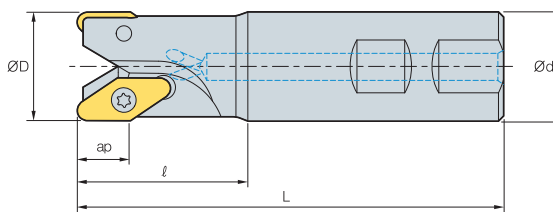

• AR : 0°~7°
• RR : -21°~-3°

Обозначение			ØD	Ød	ℓ	L	ap	
PAS	2012HR	1	12	16	25	85	8	0.1
	2016HR	2	16	16	25	90	8	0.11
	2020HR	2	20	20	30	100	8	0.2
	2025HR	3	25	25	35	115	8	0.36
	2032HR	4	32	32	40	125	8	0.66
PAS	2042HR	5	42	32	42	130	8	0.84
	4032HR	2	32	32	50	125	15	0.6
	4040HR	3	40	32	50	140	15	0.8
	4040HR-S40	3	40	40	60	150	15	1.2
	4040HR-S42	3	40	42	60	150	15	1.2

Применяемые СМП

VDKT-MA

VCKT-MA



Тип	Обозначение	Тв. сплав с покрытием									Кермет			Тв. сплав				Стр.
		NCM325	NCM335	NC5330	PC3500	PC5300	PC3545	PC9530	PC6510	PC215K	PD2000	CN2000	CN20	CN30	H01	G10	ST30A	
2000 Тип	VDKT 11T210N-MA													●				E23
4000 Тип	VCKT 220530N-MA													●				

Комплектующие



2000 Тип	ETNA02505*	TW 07S
4000 Тип	FTNC04509	TW 20S

* PAS2012 · 2016



PAM2000

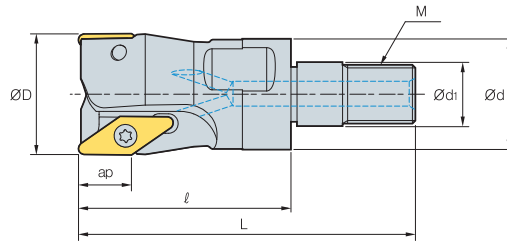

(mm)

Обозначение		ØD	Ød	Ød1	ℓ	L	M	ap	
PAM	2012HR-M06	1	12	11.0	6.5	33	M06	8	0.02
	2016HR-M08	2	16	14.5	8.5	36	M08	8	0.04
	2020HR-M10	2	20	18.0	10.5	36	M10	8	0.06
	2025HR-M12	3	25	22.5	12.5	41	M12	8	0.1
	2032HR-M16	4	32	28.5	17.0	45	M16	8	0.18
	2042HR-M16	5	42	28.5	17.0	45	M16	8	0.27

Применяемые СМП

VDKT-MA



Обозначение	Тв. сплав с покрытием								Кермет			Тв. сплав				Стр.		
	NCM325	NCM335	NC5330	PC3500	PC5300	PC3545	PC9530	PC6510	PC215K	PD2000	CN2000	CN20	CN30	H01	G10		ST30A	ST20
VDKT 11T210N-MA														●				E23

Применяемые оправки

Обозначение	Применяемые оправки
PAM 2012HR-M06	MAT - M06
2016HR-M08	MAT - M08
2020HR-M10	MAT - M10
2025HR-M12	MAT - M12
2032HR-M16	MAT - M16
2042HR-M16	MAT - M16

Обозначение : PAM2012HR-M06
Фрезерная головка с резьбой(M06)

||

Оправка : MAT-M06-030-S20S
Присоединительная резьба оправки(M06)

Комплектующие

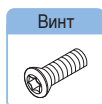

ETNA02505*
ETNA02506

TW 07S

* PAM2012-2016

Применяемые СМП смотреть на стр. E23

Применяемые оправки смотреть на стр. E233~E234

● : Наличие на складе

РАХС(М)5000

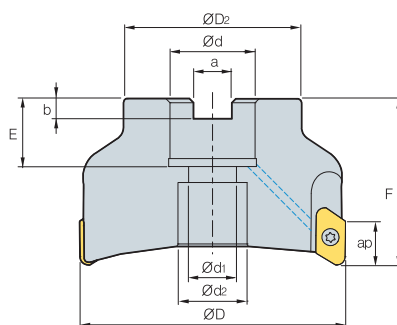

Обозначение		ØD	ØD ₂	Ød	Ød ₁	Ød ₂	a	b	E	F	Max rpm	ap	
PAXC(M) 5040HR-A,B	3	40	34	16	9	14	8.4	5.6	19	40	25,800	17	0.15
5050HR-A,B	4	50	42	22	11	18	10.4	6.3	21	50	23,000	17	0.3
5063HR-A,B	5(4)	63	49	22	11	18	10.4	6.3	21	50	20,500	17	0.56
5080HR-A,B	5	80	57	25.4(27)	14	20	9.5(12.4)	6(7)	24(23)	50	18,200	17	1.0
5100HR-A,B	6	100	67	31.75(32)	18	26	12.7(14.4)	8(8)	32(26)	63	16,300	17	2.3
5125HR-A,B	7	125	87	38.1(40)	22	32	15.9(16.4)	10(9)	35(29)	63	14,600	17	3.2

• Тип А, СМП 0.4~3.2, Тип В, СМП 4.0~5.0

• () Метрическая система

Применяемые СМП

ХЕКТ-МА



Обозначение	Тв. сплав с покрытием									Кермет			Тв. сплав				Стр.	
	NCM325	NCM335	NC5330	PC3500	PC5300	PC3545	PC9530	PC6510	PC215K	PD2000	CN2000	CN20	CN30	H01	G10	ST30A		ST20
ХЕКТ 19M504FR-MA										●				●				E23
19M508FR-MA										●				●				
19M512FR-MA										●				●				
19M516FR-MA														●				
19M518FR-MA														●				
19M520FR-MA										●				●				
19M530FR-MA														●				
19M532FR-MA										●				●				
19M540FR-MA										●				●				
19M550FR-MA										●				●				

Применяемые оправки

Обозначение	Ød	Применяемые оправки
PAXC(M) 5040HR-A,B	16	BT□□-FMC16-□□
5050HR-A,B	22	BT□□-FMC22-□□
5063HR-A,B		
5080HR-A,B	25.4	BT□□-FMA25.4-□□
	27	BT□□-FMC27-□□
5100HR-A,B	31.75	BT□□-FMA31.75-□□
	32	BT□□-FMC32-□□
5125HR-A,B	38.1	BT□□-FMA38.1-□□
	40	BT□□-FMC40-□□

Комплектующие

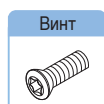

РТКА0408

TW 15S

РАХС(M)6000

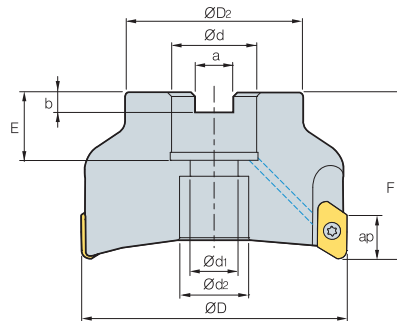

Обозначение		⊙	øD	øD ₂	ød	ød ₁	ød ₂	a	b	E	F	Max rpm	ap	kg
РАХС(M)	6050HR-A,B	2	50	42	16	9	14	8.4	5.6	18	50	23,000	23	0.32
	6063HR-A,B	3	63	49	22	11	18	10.4	6.3	21	50	20,500	23	0.53
	6080HR-A,B	4	80	57	25.4(27)	14	20	9.5(12.4)	6(7)	25(23)	50	18,200	23	0.73
	6100HR-A,B	5	100	67	31.75(32)	18	26	12.7(14.4)	8(8)	32.5(26)	63	16,300	23	1.7
	6125HR-A,B	6	125	87	38.1(40)	22	32	15.9(16.4)	10(9)	35(29)	63	14,600	23	3.06

• Тип А, СМП 0.4~3.2, Тип В, СМП 4.0~5.0

• () Метрическая система

Применяемые СМП

ХЕКТ-МА



Обозначение	Тв. сплав с покрытием							Кермет			Тв. сплав				Стр.			
	NCM325	NCM335	NC5330	PC3500	PC5300	PC3545	PC9530	PC6510	PC215K	PD2000	CN2000	CN20	CN30	H01		G10	ST30A	ST20
ХЕКТ 250604FR-MA														●				
250608FR-MA														●				
250612FR-MA														●				
250616FR-MA																		
250620FR-MA																		
250630FR-MA																		
250632FR-MA																		
250640FR-MA																		
250650FR-MA														●				

Применяемые оправки

Обозначение	ød	Применяемые оправки
РАХС(M) 6050HR-A,B	16	BT□□-FMC16-□□
6063HR-A,B	22	BT□□-FMC22-□□
6080HR-A,B	25.4	BT□□-FMA25.4-□□
	27	BT□□-FMC27-□□
6100HR-A,B	31.75	BT□□-FMA31.75-□□
	32	BT□□-FMC32-□□
6125HR-A,B	38.1	BT□□-FMA38.1-□□
	40	BT□□-FMC40-□□

Комплектующие

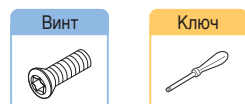

FTGA0513-P TW 20-100

Фрезерование

PAXS5000

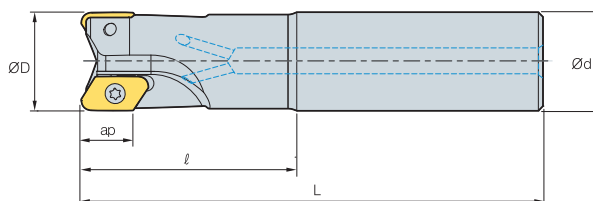

AA 90°
 • AR : 5°~10°
 • RR : -14°~5°

(MM)									
Обозначение		øD	ød	l	L	Max rpm	ap		
PAXS 5020HR-A,B	1	20	20	60	130	15,000	17	0.24	
5025HR-A,B	2	25	25	60	140	32,600	17	0.4	
5025HR-A,B-L200	2	25	25	60	200	32,600	17	0.63	
5032HR-A,B	2	32	32	70	150	28,800	17	0.74	
5032HR-A,B-L220	2	32	32	70	220	28,800	17	1.2	
5040HR-A,B-S32	3	32	32	70	160	25,800	17	1.0	
5040HR-A,B-L220	3	40	32	70	220	25,800	17	1.4	
5040HR-A,B-S40	3	40	40	70	160	25,800	17	1.3	
5040HR-A,B-S42	3	42	42	70	160	25,800	17	1.4	

• Тип А, СМП 0.4~3.2, Тип В, СМП 4.0~5.0

Применяемые СМП

ХЕКТ-МА



Обозначение	Тв. сплав с покрытием									Кермет			Тв. сплав				Стр.	
	NCM825	NCM835	NC5330	PC3500	PC5300	PC3545	PC9530	PC6510	PC215K	PD2000	CN2000	CN20	CN30	H01	G10	ST30A		ST20
ХЕКТ 19M504FR-MA										●				●				E23
19M508FR-MA										●				●				
19M512FR-MA										●				●				
19M516FR-MA										●				●				
19M518FR-MA										●				●				
19M520FR-MA										●				●				
19M530FR-MA										●				●				
19M532FR-MA										●				●				
19M540FR-MA										●				●				
19M550FR-MA										●				●				

Комплектующие

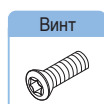

РТКА0408

TW 15S



PAXS6000

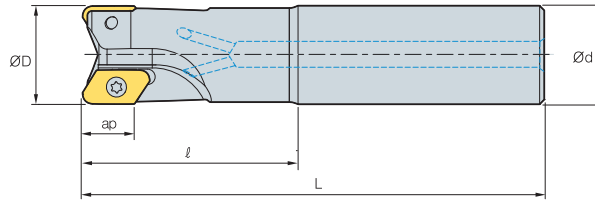

AA
90°
• AR : 5°~10°
• RR : -14°~5°

(mm)

Обозначение	СМП	øD	ød	l	L	Max rpm	ap	kg
PAXS 6025HR-A,B	1	25	25	60	140	32,600	23	0.42
6025HR-A,B-L200	1	25	25	60	200	32,600	23	0.63
6032HR-A,B	1	32	32	70	150	28,800	23	0.72
6032HR-A,B-L220	1	32	32	70	220	28,800	23	1.14
6040HR-A,B-S32	2	40	32	70	160	25,800	23	0.88
6040HR-A,B-L220	2	40	32	70	220	25,800	23	1.23
6040HR-A,B-S40	2	40	40	70	160	25,800	23	1.2
6040HR-A,B-S42	2	40	42	70	160	25,800	23	1.3

• Тип А, СМП 0.4~3.2, Тип В, СМП 4.0~5.0

Применяемые СМП

ХЕКТ-МА



Обозначение	Тв. сплав с покрытием										Кермет			Тв. сплав				Стр.
	NCM325	NCM335	NC5330	PC3500	PC5300	PC3545	PC9530	PC6510	PC215K	PD2000	CN2000	CN20	CN30	H01	G10	ST30A	ST20	
ХЕКТ 250604FR-MA														●				E23
250608FR-MA														●				
250612FR-MA														●				
250616FR-MA																		
250620FR-MA																		
250630FR-MA																		
250632FR-MA																		
250640FR-MA																		
250650FR-MA														●				

Комплектующие

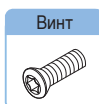

FTGA0510-P (Ø25~Ø32)
FTGA0513-P (Ø40)

TW 20-100

PAXM5000

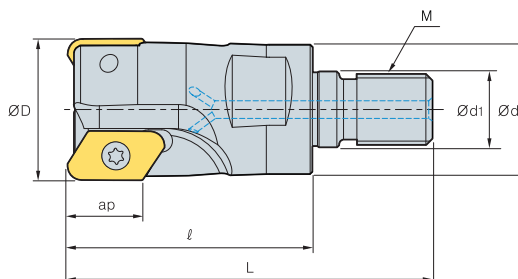

AA 90°
 • AR : 6°~8°
 • RR : -7°~5°

Обозначение		$\varnothing D$	$\varnothing d$	$\varnothing d_1$	ℓ	L	M	ap	
PAXM 5025HR-A,B-M12	2	25	23	12.5	55	79	M12	17	0.12
5032HR-A,B-M16	2	32	29	17.0	55	82	M16	17	0.2
5040HR-A,B-M16	3	40	29	17.0	55	82	M16	17	0.4

• Тип А, СМП 0.4~3.2, Тип В, СМП 4.0~5.0

Применяемые СМП

ХЕКТ-МА



Обозначение	Тв. сплав с покрытием									Кермет			Тв. сплав				Стр.	
	NCM325	NCM335	NC5330	PC3500	PC5300	PC3545	PC9530	PC6510	PC215K	PD2000	CN2000	CN20	CN30	H01	G10	ST30A		ST20
ХЕКТ 19M504FR-MA										●				●				E23
19M508FR-MA										●				●				
19M512FR-MA										●				●				
19M516FR-MA										●				●				
19M518FR-MA										●				●				
19M520FR-MA										●				●				
19M530FR-MA										●				●				
19M532FR-MA										●				●				
19M540FR-MA										●				●				
19M550FR-MA										●				●				

Применяемые оправки

Обозначение	Применяемые оправки
PAXM 5025HR-A,B-M12	MAT - M12
5032HR-A,B-M16	MAT - M16
5040HR-A,B-M16	

Обозначение : PAXM5025HR-M12
 Фрезерная головка с резьбой(M12)

II

Оправка : MAT-M12-030-S25S
 Присоединительная резьба оправки(M12)

Комплектующие



РТКА0407
 РТКА0408

TW 15S

HSK63A/100A PAX5000

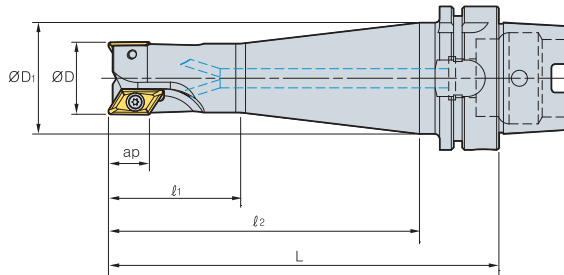

Обозначение			$\varnothing D$	$\varnothing D_1$	l_1	l_2	L	a_p	
HSK63T	PAX5032HR-A, B	2	32	53	58	137	163	17	1.14
HSK100T	PAXCM5080HR-A, B	5	80	-	-	66	95	17	4
	PAXCM5100HR-A, B	6	100	-	-	66	95	17	4.6

(мм)

• Тип А, СМП 0.4~3.2, Тип В, СМП 4.0~5.0

Применяемые СМП

ХЕКТ-МА



Обозначение	Тв. сплав с покрытием								Кермет			Тв. сплав				Стр.	
	NCM325	NCM335	NC5330	PC3500	PC5300	PC3545	PC9530	PC6510	PC215K	PD2000	CN2000	CN20	CN30	H01	G10		ST30A
ХЕКТ 19M504FR-MA										●				●			
19M508FR-MA										●				●			
19M512FR-MA										●				●			
19M516FR-MA										●				●			
19M518FR-MA										●				●			
19M520FR-MA										●				●			
19M530FR-MA										●				●			
19M532FR-MA										●				●			
19M540FR-MA										●				●			
19M550FR-MA										●				●			

Комплектующие



РТКА0407
РТКА0408

TW 15S

MAT (Стальной корпус)



Рис. 1



Рис. 2

		(мм)						
Обозначение		ØD	Ød	Ød ₁	ℓ	L	M	Рис.
MAT	M06-020-S10S	9.5	10	6.5	20	70	M06	1
	M6B-020-S12S	11.0	12	6.5	20	76	M06	1
	M6B-040-S12S	11.0	12	6.5	40	96	M06	1
	M08-020-S16S	14.5	16	8.5	20	80	M08	1
	M10-030-S20S	18.0	20	10.5	30	100	M10	1
	M12-030-S25S	22.5	25	12.5	29	110	M12	1
	M16-035-S32S	28.5	32	17.0	35	125	M16	1
	M06-040-S12T	9.5	12	6.5	40	96	M06	2
	M06-065-S16T	9.5	16	6.5	65	125	M06	2
	M6B-065-S16T	11.0	16	6.5	65	125	M06	2
	M6B-080-S16T	11.0	16	6.5	80	140	M06	2
	M08-040-S16T	14.5	16	8.5	40	100	M08	2
	M08-065-S16T	14.5	16	8.5	65	125	M08	2
	M08-080-S20T	14.5	20	8.5	80	150	M08	2
	M08-110-S25T	14.5	25	8.5	110	190	M08	2
	M10-050-S20T	18.0	20	10.5	50	120	M10	2
	M10-070-S20T	18.0	20	10.5	70	140	M10	2
	M10-090-S25T	18.0	25	10.5	90	170	M10	2
	M10-110-S25T	18.0	25	10.5	110	190	M10	2
	M10-130-S32T	18.0	32	10.5	130	220	M10	2
	M12-050-S25T	22.5	25	12.5	50	130	M12	2
	M12-070-S25T	22.5	25	12.5	70	150	M12	2
	M12-090-S25T	22.5	25	12.5	90	170	M12	2
	M12-110-S32T	22.5	32	12.5	110	200	M12	2
	M12-175-S40T	22.5	40	12.5	175	300	M12	2
	M16-055-S32T	28.5	32	17.0	55	145	M16	2
	M16-080-S32T	28.5	32	17.0	80	170	M16	2
	M16-120-S32T	28.5	32	17.0	120	210	M16	2
	M16-175-S40T	28.5	40	17.0	175	300	M16	2

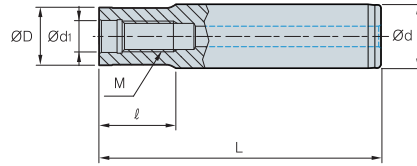
• S : усиленный тип • T : стандартный тип

Применяемые фрезерные головки смотреть на стр

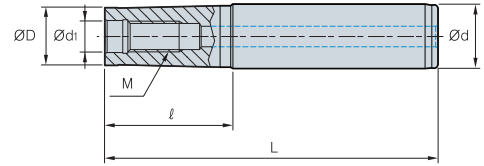
FMRM Тип



E164, 165

LBE-MHD Тип



E198

PAM Тип



E226

AMM Тип



E112, 113, 114

HRMM Тип



E185

HRMDM Тип



E179, 180

PAXM Тип



E231

Применяемые фрезерные головки смотреть на стр E33 (FMRM, LBE, PAM, AMM, RM4PM, RM4ZM, HRMM, PAXM)



MAT-C (Твердосплавный корпус)



Рис. 1



Рис. 2

		(мм)						
	Обозначение	ØD	Ød	Ød ₁	ℓ	L	M	Рис.
MAT	M08-080-S16S-C	14.5	16	8.5	80	150	M08	1
	M08-110-S16S-C	14.5	16	8.5	110	180	M08	1
	M08-150-S16S-C	14.5	16	8.5	150	250	M08	1
	M08-010-S16S-C-150	14.5	16	8.5	10	150	M08	2
	M08-010-S16S-C-180	14.5	16	8.5	10	180	M08	2
	M08-010-S16S-C-250	14.5	16	8.5	10	250	M08	2
	M10-090-S20S-C	18.0	20	10.5	90	170	M10	1
	M10-110-S20S-C	18.0	20	10.5	110	200	M10	1
	M10-175-S20S-C	18.0	20	10.5	175	300	M10	1
	M10-010-S20S-C-170	18.0	20	10.5	10	170	M10	2
	M10-010-S20S-C-200	18.0	20	10.5	10	200	M10	2
	M10-010-S20S-C-300	18.0	20	10.5	10	300	M10	2
	M12-090-S25S-C	22.5	25	12.5	90	170	M12	1
	M12-110-S25S-C	22.5	25	12.5	110	200	M12	1
	M12-175-S25S-C	22.5	25	12.5	175	300	M12	1
	M12-015-S25S-C-170	22.5	25	12.5	15	170	M12	2
	M12-015-S25S-C-200	22.5	25	12.5	15	200	M12	2
	M12-015-S25S-C-300	22.5	25	12.5	15	300	M12	2
	M16-090-S32S-C	28.5	32	17.0	90	180	M16	1
	M16-120-S32S-C	28.5	32	17.0	120	210	M16	1
M16-175-S32S-C	28.5	32	17.0	175	300	M16	1	
M16-020-S32S-C-180	28.5	32	17.0	20	180	M16	2	
M16-020-S32S-C-210	28.5	32	17.0	20	210	M16	2	
M16-020-S32S-C-300	28.5	32	17.0	20	300	M16	2	

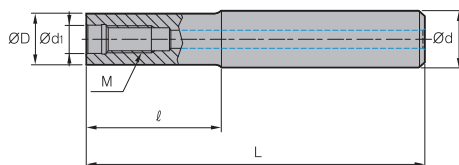
📍 Применяемые фрезерные головки смотреть на стр

FMRM Тип

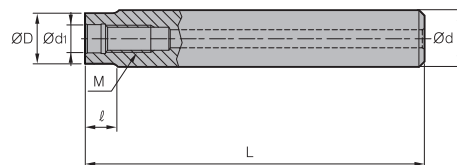

📍 E164, 165

LBE-MHD Тип



📍 E198

PAM Тип



📍 E226

AMM Тип



📍 E112, 113, 114

HRMM Тип



📍 E185

HRMDM Тип



📍 E179, 180

PAXM Тип



📍 E231

Дисковые прорезные регулируемые фрезы

Система обозначения фрез

Р : тип платформы
В : тип рельефа

А : система регулировки СМП

Для двухсторонних фрез обозначена только минимальная ширина фрезерования.

Регулировка **Тип корпуса фрезы** **Максимальная ширина фрезы**

Тип крепления пластин **Конфигурация установки** **Диаметр фрезы** **Минимальная ширина фрезы** **Тип исполнения**

R **A** **FC** **B** **125** **14** **18** **-** **R**

Р : радиальный тип для SDXT
Т : тангенциальный тип для CNHQ

FC : двусторонняя
НС : односторонняя

Обозначение	R	L
Нейтральная	Правая	Левая
Трехсторонняя посадка со шпоночным пазом	Двухсторонняя посадка со шпоночным пазом	

Тангенциальный тип крепления СМП (допускает увеличенные силы резания)

Радиальный тип (Сниженные силы резания)

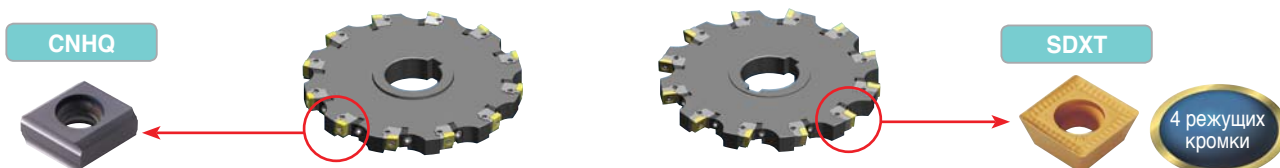

- Получистовая / Черновая обработка
- Предназначены для средних и широких пазов фрез (14~30 мм.)
- Возможность работы в тяжелых условиях обработки с переменным припуском.

- Полуцистовая / Чистовая.
- Предназначены для средних пазов (12~24)
- Широкий выбор стружколомов для различных условий резания (MF, MM, FA).
- Каждая пластина имеет 4 рабочие грани.

Особенности

- ▶ Точность регулировки СМП до 5 мкм.
- ▶ Возможность регулировки ширины реза $\pm 1,5$ мм.
- ▶ Специальная система крепления кассет обеспечивает необходимую жесткость при возникновении упругих деформаций
- ▶ Тангенциальное крепление СМП обеспечивает надежный зажим и может применяться для обработки широких пазов.
- ▶ Специальная геометрия стружколома снижает силы резания и уменьшает вероятность возникновения вибраций.

Сборка фрез и регулировка СМП

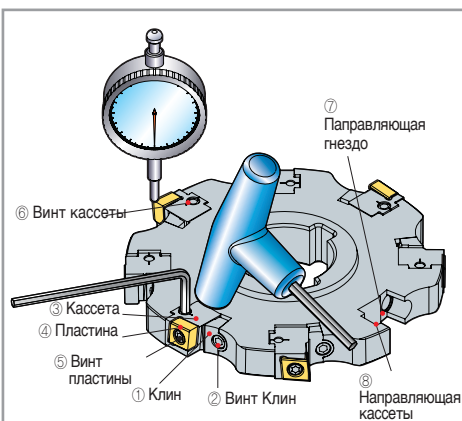

Рекомендации по сборке фрез

1. Установите и легко закрепите клин поз.(1) в гнездо фрезы при помощи ключа для клина поз. (2)
2. Установите кассету поз.(3) в направляющий паз гнезда фрезы поз.(12)
3. Закрепите ключом кассету поз.(6) для правильного позиционирования.
4. Закрепите клин ключом клина поз.(2) с усилием зажима 70 ~ 80Н.м.
5. Установите пластину поз.(4), в кассету поз.(3)и закрепите ключом для СМП поз. (5) с усилием зажима 40 - 50 Н.м.

Рекомендации по регулировке биения и ширины реза

1. Очищенную фрезу установите на приспособление для проведения измерений.
2. Выкрутите винт клина поз. 2 , отрегулируйте положение и снова закрутите с усилием 8Н.м.
3. Установите при помощи часового индикатора необходимую высоту режущих граней для заданной ширины фрезерования.
4. Закрепите винт клина поз. 2 с усилием 70 ~ 80Н.м.
5. После окончательной регулировки надежно закрепите винт кассеты поз.(6)



Фрезы с тангенциальным расположением СМП

Геометрические характеристики фрез



Обозначение	Тв. сплав с покрытием		Ширина для двухсторонних фрез	Ширина для трехсторонних фрез	CNHQ (мм)		
	NCM325	PC6510					
CNHQ1005 - C0.5			9.0	14~18	10	10	5.4
-R0.5							
-C1.0							
-R1.0			8.5	14~17			
CNHQ1305 - C0.5			12	18~21 / 21~24	12.7	10	5.4
-R0.5							
-C1.0							
-R1.0			11.5	18~21 / 21~23			
-C1.5							
-R1.5			11	18~21 / 21~22			
CNHQ1606 - C0.5			15	24~27 / 27~30	16	12	6.4
-R0.5							
-C1.0			14.5	24~27 / 27~29			
-R1.0							
-C1.5			14	24~27 / 27~28			
-R1.5							
-C2.0							
-R2.0			13.5	24~27			

Применимый держатель E237, E238

Присоединительные размеры смотреть на стр. E270~E272

● : Наличие на складе

Рекомендуемые режимы резания

ISO	Марка сплава	Vp, м/мин	Sz, мм/зуб
P	NCM325	150~300	0.10~0.30
	PC3500	100~300	
M	PC5300	100~180	0.10~0.30
	NCM335	120~200	
K	PC215K	150~250	0.10~0.30
	PC6510	150~300	

Фрезы с радиальным расположением СМП

Геометрические характеристики фрез

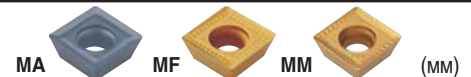

Обозначение	Тв. сплав с покрытием							Тв. сплав	Ширина для двухсторонних фрез	Ширина для трехсторонних фрез	MA MF MM (мм)	
	NCM325	NCM335	PC3500	PC3545	PC9530	PC6510	PC5300				H01	
SDXT 09M405R-MA								●	8	12~14 14~16	9.525	4
09M405L-MA												
09M405R-MF	●	●			●	●	●					
09M405L-MF												
09M405R-MM	●	●	●		●	●	●					
09M405L-MM												
SDXT 130508R-MA								●	10.5	16~18 18~20 20~22 22~24	13.5	5.56
130508L-MA												
130508R-MF	●	●			●	●	●					
130508L-MF												
130508R-MM	●	●	●	●	●	●	●					
130508L-MM												

Применимый держатель E239, E238

Присоединительные размеры смотреть на стр. E270~E272

● : Наличие на складе

Рекомендуемые режимы резания

ISO	Марка сплава	Vp, м/мин	Sz, мм/зуб
P	NCM325	120~250	0.08~0.30
	NCM335	120~220	0.08~0.25
	PC3500	100~220	0.10~0.25
M	PC9530	80~180	0.10~0.25
	PC5300		
K	PC8110	150~230	0.10~0.25
	PC6510	180~250	

Тангенциальный тип расположения СМП (Трехсторонние фрезы)

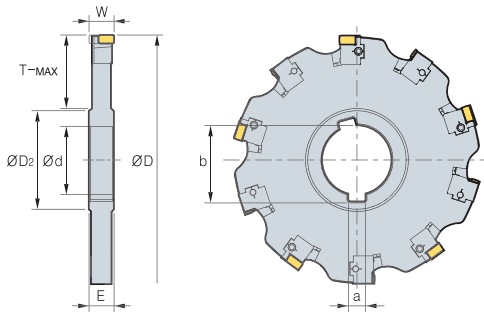

•TAFCP(M)

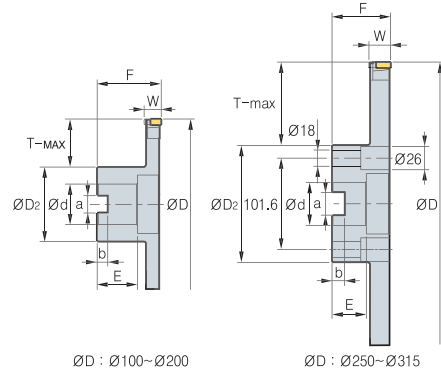

•TAFCB(M)

Обозначение	Ød	E	ØD ₂	a	b	T-MAX	Обозначение	Ød	F	ØD ₂	a	b	E	T-MAX	Основные параметры (мм)		
															ØD	W	Число зубьев
TAFCP 1001418 (M)	31.75 (32)	14	48	7.92 (8)	35.2	24	TAFCB 1001418R/L (M)	31.75 (32)	50	54	12.7 (14.4)	8	28	21	100	14-18	6
TAFCP 1251418 (M)	38.1 (40)	14	56	9.52 (10)	42.3	32	TAFCB 1251418R/L (M)	38.1 (40)	60	70	15.9 (16.4)	10	30	25	125	14-18	8
TAFCP 1601418 (M)	38.1 (40)	14	56	9.52 (10)	42.3	50	TAFCB 1601418R/L (M)	38.1 (40)	60	70	15.9 (16.4)	10	30	43	160	14-18	10
TAFCP 2001418 (M)	50.8 (50)	14	72	12.7 (12)	55.8	61	TAFCB 2001418R/L (M)	50.8 (40)	65	90	19.0 (16.4)	11	30	53	200	14-18	12
TAFCP 2501418 (M)	50.8 (50)	14	72	12.7 (12)	55.8	86	TAFCB 2501418R/L (M)	47.625 (60)	65	130	25.4 (25.7)	14	38	58	250	14-18	16
TAFCP 3151418 (M)	50.8 (50)	14	72	12.7 (12)	55.8	118	TAFCB 3151418R/L (M)	47.625 (60)	65	130	25.4 (25.7)	14	38	90	315	14-18	20
TAFCP 1001821 (M)	31.75 (32)	18	48	7.92 (8)	35.2	24	TAFCB 1001821R/L (M)	31.75 (32)	50	50	12.7 (14.4)	8	28	21	100	18-21	6
TAFCP 1251821 (M)	38.1 (40)	18	56	9.52 (10)	42.3	32	TAFCB 1251821R/L (M)	38.1 (40)	60	70	15.9 (16.4)	10	30	25	125	18-21	8
TAFCP 1601821 (M)	38.1 (40)	18	56	9.52 (10)	42.3	50	TAFCB 1601821R/L (M)	38.1 (40)	60	70	15.9 (16.4)	10	30	43	160	18-21	10
TAFCP 2001821 (M)	50.8 (50)	18	72	12.7 (12)	55.8	61	TAFCB 2001821R/L (M)	50.8 (40)	65	90	19.0 (16.4)	11	30	53	200	18-21	12
TAFCP 2501821 (M)	50.8 (50)	18	72	12.7 (12)	55.8	86	TAFCB 2501821R/L (M)	47.625 (60)	65	130	25.4 (25.7)	14	38	58	250	18-21	16
TAFCP 3151821 (M)	50.8 (50)	18	72	12.7 (12)	55.8	118	TAFCB 3151821R/L (M)	47.625 (60)	65	130	25.4 (25.7)	14	38	90	315	18-21	20
TAFCP 1002124 (M)	31.75 (32)	21	48	7.92 (8)	35.2	24	TAFCB 1002124R/L (M)	31.75 (32)	50	54	12.7 (14.4)	8	28	21	100	21-24	6
TAFCP 1252124 (M)	38.1 (40)	21	56	9.52 (10)	42.3	32	TAFCB 1252124R/L (M)	38.1 (40)	60	70	15.9 (16.4)	10	30	25	125	21-24	8
TAFCP 1602124 (M)	38.1 (40)	21	56	9.52 (10)	42.3	50	TAFCB 1602124R/L (M)	38.1 (40)	60	70	15.9 (16.4)	10	30	43	160	21-24	10
TAFCP 2002124 (M)	50.8 (50)	21	72	12.7 (12)	55.8	61	TAFCB 2002124R/L (M)	50.8 (40)	65	90	19.0 (16.4)	11	30	53	200	21-24	12
TAFCP 2502124 (M)	50.8 (50)	21	72	12.7 (12)	55.8	86	TAFCB 2502124R/L (M)	47.625 (60)	65	130	25.4 (25.7)	14	38	58	250	21-24	16
TAFCP 3152124 (M)	50.8 (50)	21	72	12.7 (12)	55.8	118	TAFCB 3152124R/L (M)	47.625 (60)	65	130	25.4 (25.7)	14	38	90	315	21-24	20
TAFCP 1252427 (M)	38.1 (40)	24	56	9.52 (10)	42.3	32	TAFCB 1252427R/L (M)	38.1 (40)	60	70	15.9 (16.4)	10	30	25	125	24-27	8
TAFCP 1602427 (M)	38.1 (40)	24	56	9.52 (10)	42.3	50	TAFCB 1602427R/L (M)	38.1 (40)	60	70	15.9 (16.4)	10	30	43	160	24-27	10
TAFCP 2002427 (M)	50.8 (50)	24	72	12.7 (12)	55.8	61	TAFCB 2002427R/L (M)	50.8 (40)	65	90	19.0 (16.4)	11	30	53	200	24-27	12
TAFCP 2502427 (M)	50.8 (50)	24	72	12.7 (12)	55.8	86	TAFCB 2502427R/L (M)	47.625 (60)	65	130	25.4 (25.7)	14	38	58	250	24-27	16
TAFCP 3152427 (M)	50.8 (50)	24	72	12.7 (12)	55.8	118	TAFCB 3152427R/L (M)	47.625 (60)	65	130	25.4 (25.7)	14	38	90	315	24-27	20
TAFCP 1252730 (M)	38.1 (40)	27	56	9.52 (10)	42.3	32	TAFCB 1252730R/L (M)	38.1 (40)	60	70	15.9 (16.4)	10	30	25	125	27-30	8
TAFCP 1602730 (M)	38.1 (40)	27	56	9.52 (10)	42.3	50	TAFCB 1602730R/L (M)	38.1 (40)	60	70	15.9 (16.4)	10	30	43	160	27-30	10
TAFCP 2002730 (M)	50.8 (50)	27	72	12.7 (12)	55.8	61	TAFCB 2002730R/L (M)	50.8 (40)	65	90	19.0 (16.4)	11	30	53	200	27-30	12
TAFCP 2502730 (M)	50.8 (50)	27	72	12.7 (12)	55.8	86	TAFCB 2502730R/L (M)	47.625 (60)	65	130	25.4 (25.7)	14	38	58	250	27-30	16
TAFCP 3152730 (M)	50.8 (50)	27	72	12.7 (12)	55.8	118	TAFCB 3152730R/L (M)	47.625 (60)	65	130	25.4 (25.7)	14	38	90	315	27-30	20

Применяемые СМП and Рекомендуемые режимы резания E256

• Максимальная ширина фрезы указана для пластин имеющих угол С0,5 или R 0,5

• () Метрическая система

Комплектующие

Ширина фрез (TAFCP/B)



□□□1418R/L	CNHQ1005-□□□	LSA-CH10R/L	WSA10N	FTKA0410	DHA0617	SHGA0411	TW15S	HW30	-
□□□1821R/L	CNHQ1305-□□□	LSA-CH13R/L	WSA13N	FTKA0410	DHA0821F	SHGA0411	TW15S	HW40	HW30L
□□□2124R/L	CNHQ1305-□□□	LSA-CH13R/L	WSA13N	FTKA0410	DHA0821F	SHGA0411	TW15S	HW40	HW30L
□□□2427R/L	CNHQ1606-□□□	LSA-CH16R/L	WSA13N	FTGA0513-P	DHA0821F	SHGA0411	TW20S	HW40	HW30L
□□□2730R/L	CNHQ1606-□□□	LSA-CH16R/L	WSA13N	FTGA0513-P	DHA0821F	SHGA0411	TW20S	HW40	HW30L

• Примечание: для фрез 1002124, 1001821 ключ клина DHA0818F



Тангенциальный тип расположения СМП (Двухсторонние фрезы)

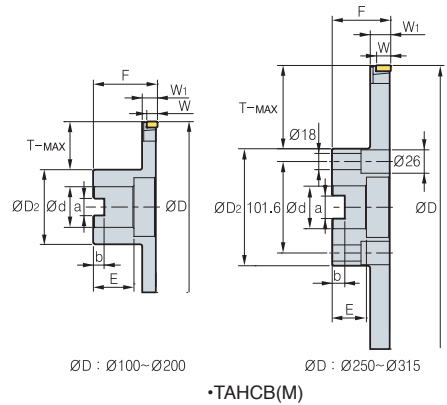
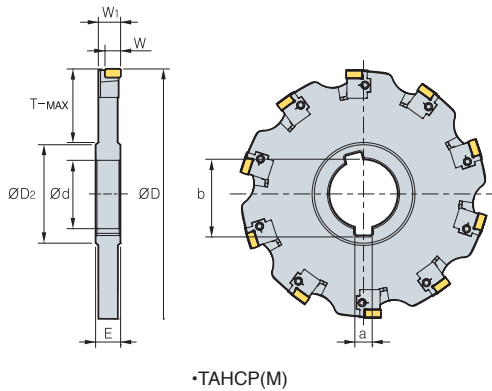

											(мм)									
Обозначение	Ød	E	ØD ₂	a	b	T-MAX	Обозначение	Ød	F	ØD ₂	a	b	E	T-MAX	Основные параметры (мм)					
															ØD	W	W ₁	Число зубьев		
ТАНСР (М)	10014R/L	31.75 (32)	14	48	7.92 (8)	35.2	24	ТАНСВ	10014R/L	31.75 (32)	50	54	12.7 (14.4)	8	28	21	100	9	13.25	6
	12514R/L	38.1 (40)	14	56	9.52 (10)	42.3	32	(М)	12514R/L	38.1 (40)	60	70	15.9 (16.4)	10	30	25	125	9	13.25	8
	16014R/L	38.1 (40)	14	56	9.52 (10)	42.3	50		16014R/L	38.1 (40)	60	70	15.9 (16.4)	10	30	43	160	9	13.25	10
	20014R/L	50.8 (50)	14	72	12.7 (12)	55.8	61		20014R/L	50.8 (40)	65	90	19.0 (16.4)	11	30	53	200	9	13.25	12
	25014R/L	50.8 (50)	14	72	12.7 (12)	55.8	86		25014R/L	47.625 (60)	65	130	25.4 (25.7)	14	38	58	250	9	13.25	16
	31514R/L	50.8 (50)	14	72	12.7 (12)	55.8	118		31514R/L	47.625 (60)	65	130	25.4 (25.7)	14	38	90	315	9	13.25	20
ТАНСР (М)	10018R/L	31.75 (32)	18	48	7.92 (8)	35.2	24	ТАНСВ	10018R/L	31.75 (32)	50	50	12.7 (14.4)	8	28	21	100	12	16.75	6
	12518R/L	38.1 (40)	18	56	9.52 (10)	42.3	32	(М)	12518R/L	38.1 (40)	60	70	15.9 (16.4)	10	30	25	125	12	16.75	8
	16018R/L	38.1 (40)	18	56	9.52 (10)	42.3	50		16018R/L	38.1 (40)	60	70	15.9 (16.4)	10	30	43	160	12	16.75	10
	20018R/L	50.8 (50)	18	72	12.7 (12)	55.8	61		20018R/L	50.8 (40)	65	90	19.0 (16.4)	11	30	53	200	12	16.75	12
	25018R/L	50.8 (50)	18	72	12.7 (12)	55.8	86		25018R/L	47.625 (60)	65	130	25.4 (25.7)	14	38	58	250	12	16.75	16
	31518R/L	50.8 (50)	18	72	12.7 (12)	55.8	118		31518R/L	47.625 (60)	65	130	25.4 (25.7)	14	38	90	315	12	16.75	20
ТАНСР (М)	10021R/L	31.75 (32)	21	48	7.92 (8)	35.2	24	ТАНСВ	10021R/L	31.75 (32)	50	54	12.7 (14.4)	8	28	21	100	12	19.75	6
	12521R/L	38.1 (40)	21	56	9.52 (10)	42.3	32	(М)	12521R/L	38.1 (40)	60	70	15.9 (16.4)	10	30	25	125	12	19.75	8
	16021R/L	38.1 (40)	21	56	9.52 (10)	42.3	50		16021R/L	38.1 (40)	60	70	15.9 (16.4)	10	30	43	160	12	19.75	10
	20021R/L	50.8 (50)	21	72	12.7 (12)	55.8	61		20021R/L	50.8 (40)	65	90	19.0 (16.4)	11	30	53	200	12	19.75	12
	25021R/L	50.8 (50)	21	72	12.7 (12)	55.8	86		25021R/L	47.625 (60)	65	130	25.4 (25.7)	14	38	58	250	12	19.75	16
	31521R/L	50.8 (50)	21	72	12.7 (12)	55.8	118		31521R/L	47.625 (60)	65	130	25.4 (25.7)	14	38	90	315	12	19.75	20
ТАНСР (М)	12524R/L	38.1 (40)	24	56	9.52 (10)	42.3	32	ТАНСВ	12524R/L	38.1 (40)	60	70	15.9 (16.4)	10	30	25	125	15	22.75	8
	16024R/L	38.1 (40)	24	56	9.52 (10)	42.3	50	(М)	16024R/L	38.1 (40)	60	70	15.9 (16.4)	10	30	43	160	15	22.75	10
	20024R/L	50.8 (50)	24	72	12.7 (12)	55.8	61		20024R/L	50.8 (40)	65	90	19.0 (16.4)	11	30	53	200	15	22.75	12
	25024R/L	50.8 (50)	24	72	12.7 (12)	55.8	86		25024R/L	47.625 (60)	65	130	25.4 (25.7)	14	38	58	250	15	22.75	16
	31524R/L	50.8 (50)	24	72	12.7 (12)	55.8	118		31524R/L	47.625 (60)	65	130	25.4 (25.7)	14	38	90	315	15	22.75	20
	ТАНСР (М)	12527R/L	38.1 (40)	27	56	9.52 (10)	42.3	32	ТАНСВ	12527R/L	38.1 (40)	60	70	15.9 (16.4)	10	30	25	125	15	25.75
16027R/L		38.1 (40)	27	56	9.52 (10)	42.3	50	(М)	16027R/L	38.1 (40)	60	70	15.9 (16.4)	10	30	43	160	15	25.75	10
20027R/L		50.8 (50)	27	72	12.7 (12)	55.8	61		20027R/L	50.8 (40)	65	90	19.0 (16.4)	11	30	53	200	15	25.75	12
25027R/L		50.8 (50)	27	72	12.7 (12)	55.8	86		25027R/L	47.625 (60)	65	130	25.4 (25.7)	14	38	58	250	15	25.75	16
31527R/L		50.8 (50)	27	72	12.7 (12)	55.8	118		31527R/L	47.625 (60)	65	130	25.4 (25.7)	14	38	90	315	15	25.75	20

Применяемые СМП and Рекомендуемые режимы резания E256

• Максимальная ширина фрезы указана для пластин имеющих угол C0,5 или R 0,5

() Метрическая система

Комплектующие

Ширина фрез
(ТАНСР/В)



□□□1418R/L	CNHQ1005-□□□	LSA-CH10R/L	WSA10N	FTKA0410	DHA0617	SHGA0411	TW15S	HW30	-
□□□1821R/L	CNHQ1305-□□□	LSA-CH13R/L	WSA13N	FTKA0410	DHA0821F	SHGA0411	TW15S	HW40	HW30L
□□□2124R/L	CNHQ1305-□□□	LSA-CH13R/L	WSA13N	FTKA0410	DHA0821F	SHGA0411	TW15S	HW40	HW30L
□□□2427R/L	CNHQ1606-□□□	LSA-CH16R/L	WSA13N	FTGA0513-P	DHA0821F	SHGA0411	TW20S	HW40	HW30L
□□□2730R/L	CNHQ1606-□□□	LSA-CH16R/L	WSA13N	FTGA0513-P	DHA0821F	SHGA0411	TW20S	HW40	HW30L

• Примечание: для фрез 1002124, 1001821 ключ клина DHA0818F

Радиальный тип расположения СМП (Трехсторонние фрезы)

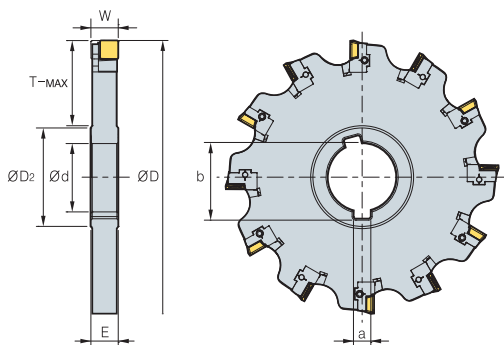

• RAFCP(M)

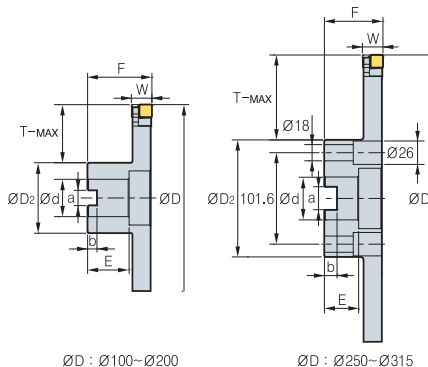

• RAFCB(M)

Обозначение	ød	E	ØD ₂	a	b	T-MAX	Обозначение	ød	F	ØD ₂	a	b	E	T-MAX	Основные параметры (мм)		
															ØD	W	Число зубьев
RAFCP 1001214 (M)	31.75 (32)	12	48	7.92 (8)	35.2	24	RAFCB 1001214R/L (M)	31.75 (32)	50	54	12.7 (14.4)	8	28	21	100	12-14	6
1251214	38.1 (40)	12	56	9.52 (10)	42.3	32	1251214R/L	38.1 (40)	60	70	15.9 (16.4)	10	30	25	125	12-14	8
1601214	38.1 (40)	12	56	9.52 (10)	42.3	50	1601214R/L	38.1 (40)	60	70	15.9 (16.4)	10	30	43	160	12-14	10
2001214	50.8 (50)	12	72	12.7 (12)	55.8	61	2001214R/L	50.8 (40)	65	90	19.0 (16.4)	11	30	53	200	12-14	12
2501214	50.8 (50)	12	72	12.7 (12)	55.8	86	2501214R/L	47.625 (60)	65	130	25.4 (25.7)	14	38	58	250	12-14	16
3151214	50.8 (50)	12	72	12.7 (12)	55.8	118	3151214R/L	47.625 (60)	65	130	25.4 (25.7)	14	38	90	315	12-14	20
RAFCP 1001416 (M)	31.75 (32)	14	48	7.92 (8)	35.2	24	RAFCB 1001416R/L (M)	31.75 (32)	50	50	12.7 (14.4)	8	28	21	100	14-16	6
1251416	38.1 (40)	14	56	9.52 (10)	42.3	32	1251416R/L	38.1 (40)	60	70	15.9 (16.4)	10	30	25	125	14-16	8
1601416	38.1 (40)	14	56	9.52 (10)	42.3	50	1601416R/L	38.1 (40)	60	70	15.9 (16.4)	10	30	43	160	14-16	10
2001416	50.8 (50)	14	72	12.7 (12)	55.8	61	2001416R/L	50.8 (40)	65	90	19.0 (16.4)	11	30	53	200	14-16	12
2501416	50.8 (50)	14	72	12.7 (12)	55.8	86	2501416R/L	47.625 (60)	65	130	25.4 (25.7)	14	38	58	250	14-16	16
3151416	50.8 (50)	14	72	12.7 (12)	55.8	118	3151416R/L	47.625 (60)	65	130	25.4 (25.7)	14	38	90	315	14-16	20
RAFCP 1251618 (M)	38.1 (40)	16	56	9.52 (10)	42.3	32	RAFCB 1251618R/L (M)	38.1 (40)	60	70	15.9 (16.4)	10	30	25	125	16-18	8
1601618	38.1 (40)	16	56	9.52 (10)	42.3	50	1601618R/L	38.1 (40)	60	70	15.9 (16.4)	10	30	43	160	16-18	10
2001618	50.8 (50)	16	72	12.7 (12)	55.8	61	2001618R/L	50.8 (40)	65	90	19.0 (16.4)	11	30	53	200	16-18	12
2501618	50.8 (50)	16	72	12.7 (12)	55.8	86	2501618R/L	47.625 (60)	65	130	25.4 (25.7)	14	38	58	250	16-18	16
3151618	50.8 (50)	16	72	12.7 (12)	55.8	118	3151618R/L	47.625 (60)	65	130	25.4 (25.7)	14	38	90	315	16-18	20
RAFCP 1251820 (M)	38.1 (40)	18	56	9.52 (10)	42.3	32	RAFCB 1251820R/L (M)	38.1 (40)	60	70	15.9 (16.4)	10	30	25	125	18-20	8
1601820	38.1 (40)	18	56	9.52 (10)	42.3	50	1601820R/L	38.1 (40)	60	70	15.9 (16.4)	10	30	43	160	18-20	10
2001820	50.8 (50)	18	72	12.7 (12)	55.8	61	2001820R/L	50.8 (40)	65	90	19.0 (16.4)	11	30	53	200	18-20	12
2501820	50.8 (50)	18	72	12.7 (12)	55.8	86	2501820R/L	47.625 (60)	65	130	25.4 (25.7)	14	38	58	250	18-20	16
3151820	50.8 (50)	18	72	12.7 (12)	55.8	118	3151820R/L	47.625 (60)	65	130	25.4 (25.7)	14	38	90	315	18-20	20
RAFCP 1252022 (M)	38.1 (40)	20	56	9.52 (10)	42.3	32	RAFCB 1252022R/L (M)	38.1 (40)	60	70	15.9 (16.4)	10	30	25	125	20-22	8
1602022	38.1 (40)	20	56	9.52 (10)	42.3	50	1602022R/L	38.1 (40)	60	70	15.9 (16.4)	10	30	43	160	20-22	10
2002022	50.8 (50)	20	72	12.7 (12)	55.8	61	2002022R/L	50.8 (40)	65	90	19.0 (16.4)	11	30	53	200	20-22	12
2502022	50.8 (50)	20	72	12.7 (12)	55.8	86	2502022R/L	47.625 (60)	65	130	25.4 (25.7)	14	38	58	250	20-22	16
3152022	50.8 (50)	20	72	12.7 (12)	55.8	118	3152022R/L	47.625 (60)	65	130	25.4 (25.7)	14	38	90	315	20-22	20
RAFCP 1252224 (M)	38.1 (40)	22	56	9.52 (10)	42.3	32	RAFCB 1252224R/L (M)	38.1 (40)	60	70	15.9 (16.4)	10	30	25	125	22-24	8
1602224	38.1 (40)	22	56	9.52 (10)	42.3	50	1602224R/L	38.1 (40)	60	70	15.9 (16.4)	10	30	43	160	22-24	10
2002224	50.8 (50)	22	72	12.7 (12)	55.8	61	2002224R/L	50.8 (40)	65	90	19.0 (16.4)	11	30	53	200	22-24	12
2502224	50.8 (50)	22	72	12.7 (12)	55.8	86	2502224R/L	47.625 (60)	65	130	25.4 (25.7)	14	38	58	250	22-24	16
3152224	50.8 (50)	22	72	12.7 (12)	55.8	118	3152224R/L	47.625 (60)	65	130	25.4 (25.7)	14	38	90	315	22-24	20

Применяемые СМП и Рекомендуемые режимы резания E256

• Максимальная ширина фрезы указана для пластин имеющих угол C0,5 или R 0,5

• () Метрическая система

Комплектующие

Ширина фрез (RAFCP/B)

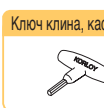
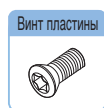
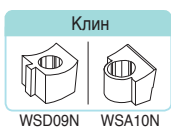
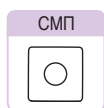

1214R/L	SDXT09M40 R/L	LSD09R/L	WSD09N	WSD09N	FTGA03508	DHA0617	SHGA0409	TW15S	HW30
1416R/L	SDXT09M40 R/L	LSD09R/L	WSD09N	WSD09N	FTGA03508	DHA0617	SHGA0409	TW15S	HW30
1618R/L	SDXT13050 R/L	LSD13R/L	WSA10N	WSA10N	FTNC04509	DHA0617	SHGA0411	TW20S	HW30
1820R/L	SDXT13050 R/L	LSD13R/L	WSA10N	WSA10N	FTNC04509	DHA0617	SHGA0411	TW20S	HW30
2022R/L	SDXT13050 R/L	LSD13R/L	WSA10N	WSA10N	FTNC04509	DHA0617	SHGA0411	TW20S	HW30
2224R/L	SDXT13050 R/L	LSD13R/L	WSA10N	WSA10N	FTNC04509	DHA0617	SHGA0411	TW20S	HW30



Радиальный тип расположения СМП (Двухсторонние фрезы)

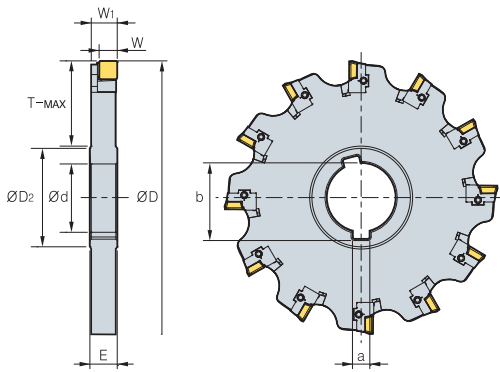

• RAHCP(M)

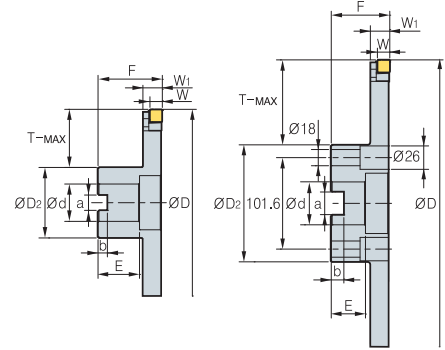

ØD : Ø100~Ø200

ØD : Ø250~Ø315

• RAHCB(M)

Обозначение		Ød	E	ØD ₂	a	b	T-MAX	Обозначение		Ød	F	ØD ₂	a	b	E	T-MAX	Основные параметры (мм)			
																	ØD	W	W	Число зубьев
RAHCP (M)	10012R/L	31.75 (32)	12	48	7.92 (8)	35.2	24	RAHCB (M)	10012R/L	31.75 (32)	50	54	12.7 (14.4)	8	28	21	100	8	11.1	6
	12512R/L	38.1 (40)	12	56	9.52 (10)	42.3	32		12512R/L	38.1 (40)	60	70	15.9 (16.4)	10	30	25	125	8	11.1	8
	16012R/L	38.1 (40)	12	56	9.52 (10)	42.3	50		16012R/L	38.1 (40)	60	70	15.9 (16.4)	10	30	43	160	8	11.1	10
	20012R/L	50.8 (50)	12	72	12.7 (12)	55.8	61		20012R/L	50.8 (40)	65	90	19.0 (16.4)	11	30	53	200	8	11.1	12
	25012R/L	50.8 (50)	12	72	12.7 (12)	55.8	86		25012R/L	47.625 (60)	65	130	25.4 (25.7)	14	38	58	250	8	11.1	16
	31512R/L	50.8 (50)	12	72	12.7 (12)	55.8	118		31512R/L	47.625 (60)	65	130	25.4 (25.7)	14	38	90	315	8	11.1	20
RAHCP (M)	10014R/L	31.75 (32)	14	48	7.92 (8)	35.2	24	RAHCB (M)	10014R/L	31.75 (32)	50	50	12.7 (14.4)	8	28	21	100	8	13.1	6
	12514R/L	38.1 (40)	14	56	9.52 (10)	42.3	32		12514R/L	38.1 (40)	60	70	15.9 (16.4)	10	30	25	125	8	13.1	8
	16014R/L	38.1 (40)	14	56	9.52 (10)	42.3	50		16014R/L	38.1 (40)	60	70	15.9 (16.4)	10	30	43	160	8	13.1	10
	20014R/L	50.8 (50)	14	72	12.7 (12)	55.8	61		20014R/L	50.8 (40)	65	90	19.0 (16.4)	11	30	53	200	8	13.1	12
	25014R/L	50.8 (50)	14	72	12.7 (12)	55.8	86		25014R/L	47.625 (60)	65	130	25.4 (25.7)	14	38	58	250	8	13.1	16
	31514R/L	50.8 (50)	14	72	12.7 (12)	55.8	118		31514R/L	47.625 (60)	65	130	25.4 (25.7)	14	38	90	315	8	13.1	20
RAHCP (M)	12516R/L	38.1 (40)	16	56	9.52 (10)	42.3	32	RAHCB (M)	12516R/L	38.1 (40)	60	70	15.9 (16.4)	10	30	25	125	10.5	15	8
	16016R/L	38.1 (40)	16	56	9.52 (10)	42.3	50		16016R/L	38.1 (40)	60	70	15.9 (16.4)	10	30	43	160	10.5	15	10
	20016R/L	50.8 (50)	16	72	12.7 (12)	55.8	61		20016R/L	50.8 (40)	65	90	19.0 (16.4)	11	30	53	200	10.5	15	12
	25016R/L	50.8 (50)	16	72	12.7 (12)	55.8	86		25016R/L	47.625 (60)	65	130	25.4 (25.7)	14	38	58	250	10.5	15	16
	31516R/L	50.8 (50)	16	72	12.7 (12)	55.8	118		31516R/L	47.625 (60)	65	130	25.4 (25.7)	14	38	90	315	10.5	15	20
	RAHCP (M)	12518R/L	38.1 (40)	18	56	9.52 (10)	42.3		32	RAHCB (M)	12518R/L	38.1 (40)	60	70	15.9 (16.4)	10	30	25	125	10.5
16018R/L		38.1 (40)	18	56	9.52 (10)	42.3	50	16018R/L	38.1 (40)		60	70	15.9 (16.4)	10	30	43	160	10.5	17	10
20018R/L		50.8 (50)	18	72	12.7 (12)	55.8	61	20018R/L	50.8 (40)		65	90	19.0 (16.4)	11	30	53	200	10.5	17	12
25018R/L		50.8 (50)	18	72	12.7 (12)	55.8	86	25018R/L	47.625 (60)		65	130	25.4 (25.7)	14	38	58	250	10.5	17	16
31518R/L		50.8 (50)	18	72	12.7 (12)	55.8	118	31518R/L	47.625 (60)		65	130	25.4 (25.7)	14	38	90	315	10.5	17	20
RAHCP (M)		12520R/L	38.1 (40)	20	56	9.52 (10)	42.3	32	RAHCB (M)		12520R/L	38.1 (40)	60	70	15.9 (16.4)	10	30	25	125	10.5
	16020R/L	38.1 (40)	20	56	9.52 (10)	42.3	50	16020R/L		38.1 (40)	60	70	15.9 (16.4)	10	30	43	160	10.5	19	10
	20020R/L	50.8 (50)	20	72	12.7 (12)	55.8	61	20020R/L		50.8 (40)	65	90	19.0 (16.4)	11	30	53	200	10.5	19	12
	25020R/L	50.8 (50)	20	72	12.7 (12)	55.8	86	25020R/L		47.625 (60)	65	130	25.4 (25.7)	14	38	58	250	10.5	19	16
	31520R/L	50.8 (50)	20	72	12.7 (12)	55.8	118	31520R/L		47.625 (60)	65	130	25.4 (25.7)	14	38	90	315	10.5	19	20
	RAHCP (M)	12522R/L	38.1 (40)	22	56	9.52 (10)	42.3	32		RAHCB (M)	12522R/L	38.1 (40)	60	70	15.9 (16.4)	10	30	25	125	10.5
16022R/L		38.1 (40)	22	56	9.52 (10)	42.3	50	16022R/L	38.1 (40)		60	70	15.9 (16.4)	10	30	43	160	10.5	21	10
20022R/L		50.8 (50)	22	72	12.7 (12)	55.8	61	20022R/L	50.8 (40)		65	90	19.0 (16.4)	11	30	53	200	10.5	21	12
25022R/L		50.8 (50)	22	72	12.7 (12)	55.8	86	25022R/L	47.625 (60)		65	130	25.4 (25.7)	14	38	58	250	10.5	21	16
31522R/L		50.8 (50)	22	72	12.7 (12)	55.8	118	31522R/L	47.625 (60)		65	130	25.4 (25.7)	14	38	90	315	10.5	21	20

Применяемые СМП and Рекомендуемые режимы резания E256

• Максимальная ширина фрезы указана для пластин имеющих угол C0,5 или R 0,5.
• Изготавливаются под заказ.

Комплектующие

() Метрическая система

Ширина фрез
(RAHCP/B)

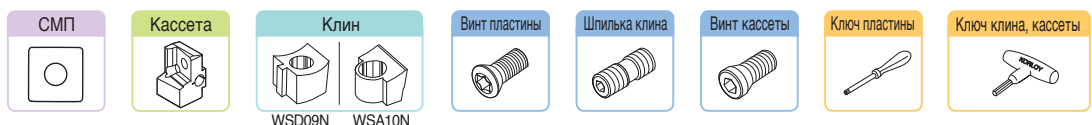

□□□ 1214R/L	SDXT09M40□ R/L	LSD09R/L	WSD09N	WSD09N	FTGA03508	DHA0617	SHGA0409	TW15S	HW30
□□□ 1416R/L	SDXT09M40□ R/L	LSD09R/L	WSD09N	WSD09N	FTGA03508	DHA0617	SHGA0409	TW15S	HW30
□□□ 1618R/L	SDXT13050□ R/L	LSD13R/L	WSA10N	WSA10N	FTNC04509	DHA0617	SHGA0411	TW20S	HW30
□□□ 1820R/L	SDXT13050□ R/L	LSD13R/L	WSA10N	WSA10N	FTNC04509	DHA0617	SHGA0411	TW20S	HW30
□□□ 2022R/L	SDXT13050□ R/L	LSD13R/L	WSA10N	WSA10N	FTNC04509	DHA0617	SHGA0411	TW20S	HW30
□□□ 2224R/L	SDXT13050□ R/L	LSD13R/L	WSA10N	WSA10N	FTNC04509	DHA0617	SHGA0411	TW20S	HW30

FC(M) (Трехсторонние фрезы)

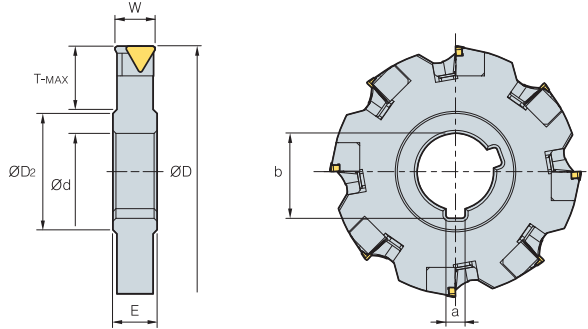

• AR : 5°
• RR : 0°

(мм)

Обозначение		ØD	W	T-MAX	Ød	E	a	b	ØD2	СМП
FC(M) 08010	6	80	10	17.0	25.4 (27)	12	6.35 (7)	28	41.5	TPCN1103PPN
10012	8	100	12	24.0	31.75 (32)	14	7.92 (8)	35.2	48	TPCN1103PPN
12512	10	125	12	31.5	38.1 (40)	14	9.52 (10)	42.3	58	TPCN1103PPN
12520	8	125	20	31.5	38.1 (40)	22	9.52 (10)	42.3	58	TPCN1103PPN
16012	12	160	12	49.0	38.1 (40)	14	9.52 (10)	42.3	58	TPCN1103PPN
16016	12	160	16	49.0	38.1 (40)	18	9.52 (10)	42.3	58	TPCN1103PPN
16018	10	10	18	49.0	38.1 (40)	20	9.52 (10)	42.3	58	TPCN1603PPN
16020	10	10	20	49.0	38.1 (40)	22	9.52 (10)	42.3	58	TPCN1603PPN
20022	12	200	22	61.0	50.8 (50)	24	12.7 (12)	55.8	72	TPCN1603PPN
25024	16	250	24	81.0	50.8 (50)	26	12.7 (12)	55.8	84	TPCN1603PPN
31524	16	315	24	113.5	50.8 (50)	26	12.7 (12)	55.8	84	TPCN1603PPN

• () Метрическая система

Применяемые СМП

TPCN



Обозначение	Тв. сплав с покрытием								Кермет			Тв. сплав				Стр.	
	NCM325	NCM335	NC5330	PC3500	PC5300	PC3545	PC9530	PC6510	PC215K	PD2000	CN2000	CN20	CN30	H01	G10		ST30A
TPCN 1103PPN																	
1603PPN	●							●				●		●	●	●	

Применяемые оправки

Обозначение	Оправка	
FC(M) 08010	BT40-SCA27-75/120	BT50-SCA27-90/135
10012	BT40-SCA32-105	BT50-SCA32-90/135
12512	-	BT50-SCA40-90/135
12520	-	BT50-SCA40-90/135
16012	-	BT50-SCA40-90/135
16018	-	BT50-SCA40-90/135
16020	-	BT50-SCA40-90/135
20022	-	-
25024	-	-
31524	-	-

Рекомендуемые режимы резания

Обрабатываемые материалы	Режимы резания		Марка сплава
	Vp, м/мин	Sz, мм/зуб	
P	150 ~ 250	0.10 ~ 0.25	NCM325 PC3500 ST30A
	120 ~ 200	0.10 ~ 0.30	
	100 ~ 150	0.10 ~ 0.30	
M	80 ~ 180	0.10 ~ 0.25	PC9530 ST30A
	80 ~ 150	0.10 ~ 0.30	
K	130 ~ 200	0.10 ~ 0.35	PC6510 G10
	100 ~ 150	0.10 ~ 0.40	

Комплектующие



Кассета



Клин



Винт

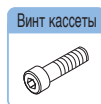

Винт кассеты



Ключ

LFC2R/L · LFC3R/L	WFC2N · WFC3N	DHA0617	MHB0310	HW30L
LFC2R/L-1*	WFC2N-1*	DHA0815	MHB0410	HW40L

* FC08010

Схема сборки

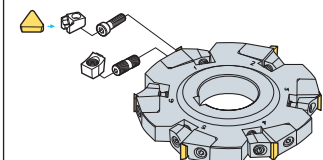

Применяемые СМП смотреть на стр. E22



Присоединительные размеры смотреть на стр. E270~E272

● : Наличие на складе



НС(М) (Двухсторонние фрезы)

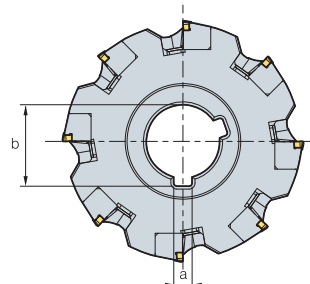
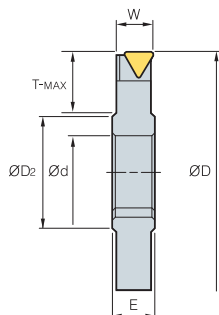

- AR : 5°
- RR : 0°

(мм)

Обозначение		ØD	W	T-MAX	Ød	E	a	b	ØD2	СМП
НС(М) 10024R/L	6	100	24	24.0	31.75 (32)	27	7.92 (8)	35.2	48	TPCN1603PPN
12524R/L	8	125	24	31.5	38.1 (40)	27	9.52 (10)	42.3	58	TPCN1603PPN
16024R/L	10	160	24	49.0	38.1 (40)	27	9.52 (10)	42.3	58	TPCN1603PPN
20024R/L	12	200	24	62.0	50.8 (50)	27	12.7 (12)	55.8	72	TPCN1603PPN
25024R/L	16	250	24	81.0	50.8 (50)	27	12.7 (12)	55.8	84	TPCN1603PPN
31524R/L	20	315	24	113.5	50.8 (50)	27	12.7 (12)	55.8	84	TPCN1603PPN

• () Метрическая система

Применяемые СМП

TPCN



Обозначение	Тв. сплав с покрытием							Кермет			Тв. сплав			Стр.				
	NCM325	NCM335	NC5330	PC3500	PC5300	PC3545	PC9530	PC6510	PC215K	PD2000	CN2000	CN20	CN30		H01	G10	ST30A	ST20
TPCN 1603PPN	●							●					●		●			E22

Применяемые оправки

Обозначение	Оправка	
	НС(М) 10024R/L	BT40-SCA31.75-105
12524R/L	-	BT50-SCA38.1-90/135
16024R/L	-	BT50-SCA38.1-90/135
20024R/L	-	-
25024R/L	-	-
31524R/L	-	-

Рекомендуемые режимы резания

Обрабатываемые материалы	Режимы резания		Марка сплава
	Vp, м/мин	Sz, мм/зуб	
P	150 ~ 250	0.10 ~ 0.25	NCM325 PC3500 ST30A
	120 ~ 200	0.10 ~ 0.30	
	100 ~ 150	0.10 ~ 0.30	
M	80 ~ 180	0.10 ~ 0.25	PC9530 ST30A
	80 ~ 150	0.10 ~ 0.30	
K	130 ~ 200	0.10 ~ 0.35	PC6510 G10
	100 ~ 150	0.10 ~ 0.40	

Комплектующие



Кассета

LFC3R/L



Клин

WFC3N



Винт

DHA0815



Винт кассеты

MHB0410



Ключ

HW40L

Схема сборки

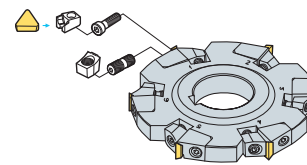

SPP(M)

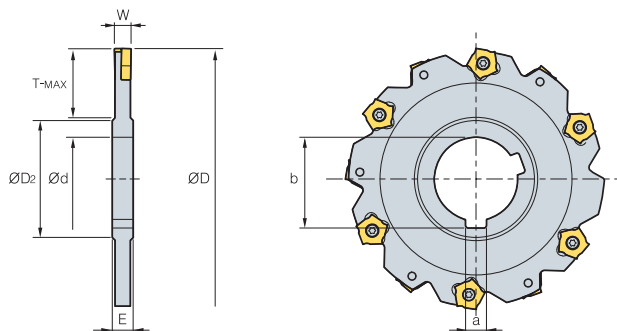

- AR : -2°
- RR : -28°

(мм)

Обозначение		ØD	W	T-MAX	Ød	a	b	E	ØD2	СМП	Винт	Ключ
SPP(M) 080-04	8	80	4	20	25.4(27)	6.35(7)	28.04(29.8)	8	40	PNEJ1223N	PTMA0403F	TW15S
080-05	8	80	5	20	25.4(27)	6.35(7)	28.04(29.8)	8	40	PNEJ1230N	PTMA0404F	TW15S
080-06	8	80	6	20	25.4(27)	6.35(7)	28.04(29.8)	8	40	PNEJ1235N	PTMA0405F	TW15S
100-04	10	100	4	24	31.75(32)	7.94(8)	35.18(34.8)	8	47	PNEJ1223N	PTMA0403F	TW15S
100-05	10	100	5	24	31.75(32)	7.94(8)	35.18(34.8)	8	47	PNEJ1230N	PTMA0404F	TW15S
100-06	10	100	6	25	31.75(32)	7.94(8)	35.18(34.8)	8	47	PNEJ1235N	PTMA0405F	TW15S
100-07	10	100	7	25	31.75(32)	7.94(8)	35.18(34.8)	10	47	PNEJ1240N	PTMA0406F	TW15S
100-08	10	100	8	25	31.75(32)	7.94(8)	35.18(34.8)	10	47	PNEJ1245N	PTKA0407F	TW15S
100-09	10	100	9	25	31.75(32)	7.94(8)	35.18(34.8)	12	47	PNEJ1250N	PTKA0408F	TW15S
100-10	10	100	10	25	31.75(32)	7.94(8)	35.18(34.8)	12	47	PNEJ1255N	PTKA0409F	TW15S
125-04	12	125	4	30	38.1(40)	9.53(10)	42.32(43.5)	8	56	PNEJ1223N	PTMA0403F	TW15S
125-05	12	125	5	32	38.1(40)	9.53(10)	42.32(43.5)	8	56	PNEJ1230N	PTMA0404F	TW15S
125-06	12	125	6	32	38.1(40)	9.53(10)	42.32(43.5)	8	56	PNEJ1235N	PTMA0405F	TW15S
125-07	12	125	7	32	38.1(40)	9.53(10)	42.32(43.5)	10	56	PNEJ1240N	PTMA0406F	TW15S
125-08	12	125	8	32	38.1(40)	9.53(10)	42.32(43.5)	10	56	PNEJ1245N	PTKA0407F	TW15S
125-09	12	125	9	32	38.1(40)	9.53(10)	42.32(43.5)	12	56	PNEJ1250N	PTKA0408F	TW15S
125-10	12	125	10	32	38.1(40)	9.53(10)	42.32(43.5)	12	56	PNEJ1255N	PTKA0409F	TW15S
160-04	16	160	4	45	38.1(40)	9.53(10)	42.32(43.5)	8	66	PNEJ1223N	PTMA0403F	TW15S
160-05	16	160	5	45	38.1(40)	9.53(10)	42.32(43.5)	8	66	PNEJ1230N	PTMA0404F	TW15S
160-06	16	160	6	45	38.1(40)	9.53(10)	42.32(43.5)	8	66	PNEJ1235N	PTMA0405F	TW15S
160-07	16	160	7	45	38.1(40)	9.53(10)	42.32(43.5)	10	66	PNEJ1240N	PTMA0406F	TW15S
160-08	16	160	8	45	38.1(40)	9.53(10)	42.32(43.5)	10	66	PNEJ1245N	PTKA0407F	TW15S
160-09	16	160	9	45	38.1(40)	9.53(10)	42.32(43.5)	12	66	PNEJ1250N	PTKA0408F	TW15S
160-10	16	160	10	45	38.1(40)	9.53(10)	42.32(43.5)	12	66	PNEJ1255N	PTKA0409F	TW15S
160-11	16	160	11	45	38.1(40)	9.53(10)	42.32(43.5)	14	66	PNEJ1260N	PTKA0410F	TW15S
160-12	16	160	12	45	38.1(40)	9.53(10)	42.32(43.5)	14	66	PNEJ1265N	PTKA0411F	TW15S
160-13	16	160	13	45	38.1(40)	9.53(10)	42.32(43.5)	16	66	PNEJ1270N	PTKA0412F	TW15S
160-14	16	160	14	45	38.1(40)	9.53(10)	42.32(43.5)	16	66	PNEJ1275N	PTMA0413F	TW15S
200-06	18	200	6	60	50.8(50)	12.7(12)	55.83(53.5)	8	70	PNEJ1235N	PTMA0405F	TW15S
200-07	18	200	7	60	50.8(50)	12.7(12)	55.83(53.5)	10	70	PNEJ1240N	PTMA0406F	TW15S
200-08	18	200	8	60	50.8(50)	12.7(12)	55.83(53.5)	10	70	PNEJ1245N	PTKA0407F	TW15S
200-09	18	200	9	60	50.8(50)	12.7(12)	55.83(53.5)	12	70	PNEJ1250N	PTKA0408F	TW15S
200-10	18	200	10	60	50.8(50)	12.7(12)	55.83(53.5)	12	70	PNEJ1255N	PTKA0409F	TW15S
200-11	18	200	11	60	50.8(50)	12.7(12)	55.83(53.5)	14	70	PNEJ1260N	PTKA0410F	TW15S
200-12	18	200	12	60	50.8(50)	12.7(12)	55.83(53.5)	14	70	PNEJ1265N	PTKA0411F	TW15S
200-13	18	200	13	60	50.8(50)	12.7(12)	55.83(53.5)	16	70	PNEJ1270N	PTKA0412F	TW15S
200-14	18	200	14	60	50.8(50)	12.7(12)	55.83(53.5)	16	70	PNEJ1275N	PTKA0413F	TW15S

• () Метрическая система

Применяемые оправки

Обозначение	Оправка		
	BT30	BT40	BT50
SPP 080-04~06	BT30-SCA25.4-60	BT40-SCA25.4-75/120	BT50-SCA25.4-90/135
100-04~10	-	BT40-SCA31.75-105	BT50-SCA31.75-90/135
125-04-09	-	-	BT50-SCA38.1-90/135
160-04-14	-	-	BT50-SCA38.1-90/135
200-06-14	-	-	-
SPPM 080-04~06	-	BT40-SCA27-75/120	BT50-SCA27-90/135
100-04~10	-	BT40-SCA32-105	BT50-SCA32-90/135
125-04-09	-	-	BT50-SCA40-90/135
160-04-14	-	-	BT50-SCA40-90/135
200-06-14	-	-	-

Рекомендуемые режимы резания

Обрабатываемые материалы	Режимы резания		Марка сплава
	V _p , м/мин	S _z , мм/зуб	
P	150 ~ 250	0.10 ~ 0.25	NCM325 PC3500 ST30A
	120 ~ 200	0.10 ~ 0.30	
	100 ~ 150	0.10 ~ 0.30	
M	80 ~ 180	0.10 ~ 0.25	PC9530 ST30A
	80 ~ 150	0.10 ~ 0.30	
K	130 ~ 200	0.10 ~ 0.35	PC6510 G10
	100 ~ 150	0.10 ~ 0.40	

Система обозначения

S	P	P	160	-	06	R
Вид обработки (S отрезание)	Вид посадочного отверстия (P: отверстие со шпоночным пазом, B: цилиндр со шпоночным пазом на торце)		Диаметр фрезы(ØD)		Ширина реза (W)	Исполнение фрезы (L левое / R правое)
Форма СМП (P пятигранная пластина)						

Применяемые СМП смотреть на стр. E12

Присоединительные размеры смотреть на стр. E270~E272



SPB(M)

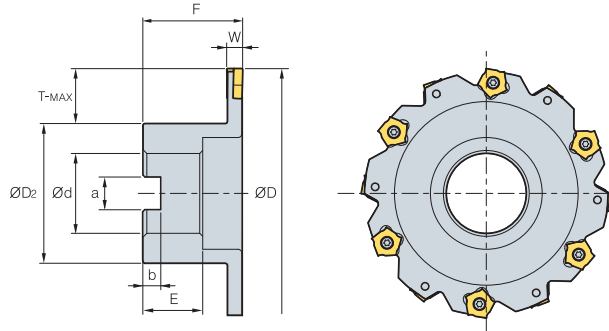

• AR : -10°
• RR : 0°

(мм)

Обозначение	ØD	W	T-max	ØD ₂	ød	a	b	F	E	СМП	Винт	Ключ	
SPB(M) 080-04R/L	8	80	4	18	40	25.4(27)	9.5(12.4)	6(7)	50	25(22)	PNEJ1223N	PTMA0403F	TW15S
080-05R/L	8	80	5	18	40	25.4(27)	9.5(12.4)	6(7)	50	25(22)	PNEJ1230N	PTMA0404F	TW15S
080-06R/L	8	80	6	18	40	25.4(27)	9.5(12.4)	6(7)	50	25(22)	PNEJ1235N	PTMA0405F	TW15S
100-04R/L	10	100	4	21	54	31.75(32)	12.7(14.4)	8(8)	50	32(28)	PNEJ1223N	PTMA0403F	TW15S
100-05R/L	10	100	5	21	54	31.75(32)	12.7(14.4)	8(8)	50	32(28)	PNEJ1230N	PTMA0404F	TW15S
100-06R/L	10	100	6	21	54	31.75(32)	12.7(14.4)	8(8)	50	32(28)	PNEJ1235N	PTMA0405F	TW15S
100-07R/L	10	100	7	21	54	31.75(32)	12.7(14.4)	8(8)	50	32(28)	PNEJ1240N	PTMA0406F	TW15S
100-08R/L	10	100	8	21	54	31.75(32)	12.7(14.4)	8(8)	50	32(28)	PNEJ1245N	PTMA0407F	TW15S
100-09R/L	10	100	9	21	54	31.75(32)	12.7(14.4)	8(8)	50	32(28)	PNEJ1250N	PTMA0408F	TW15S
100-10R/L	10	100	10	21	54	31.75(32)	12.7(14.4)	8(8)	50	32(28)	PNEJ1255N	PTMA0409F	TW15S
125-04R/L	12	125	4	25	70	38.1(40)	15.9(16.4)	10(9)	60(50)	38(30)	PNEJ1223N	PTMA0403F	TW15S
125-05R/L	12	125	5	25	70	38.1(40)	15.9(16.4)	10(9)	60(50)	38(30)	PNEJ1230N	PTMA0404F	TW15S
125-06R/L	12	125	6	25	70	38.1(40)	15.9(16.4)	10(9)	60(50)	38(30)	PNEJ1235N	PTMA0405F	TW15S
125-07R/L	12	125	7	25	70	38.1(40)	15.9(16.4)	10(9)	60(50)	38(30)	PNEJ1240N	PTMA0406F	TW15S
125-08R/L	12	125	8	25	70	38.1(40)	15.9(16.4)	10(9)	60(50)	38(30)	PNEJ1245N	PTKA0407F	TW15S
125-09R/L	12	125	9	25	70	38.1(40)	15.9(16.4)	10(9)	60(50)	38(30)	PNEJ1250N	PTKA0408F	TW15S
125-10R/L	12	125	10	25	70	38.1(40)	15.9(16.4)	10(9)	60(50)	38(30)	PNEJ1255N	PTKA0409F	TW15S
160-04R/L	16	160	4	43	70	38.1(40)	15.9(16.4)	10(9)	60(50)	38(30)	PNEJ1223N	PTMA0403F	TW15S
160-05R/L	16	160	5	43	70	38.1(40)	15.9(16.4)	10(9)	60(50)	38(30)	PNEJ1230N	PTMA0404F	TW15S
160-06R/L	16	160	6	43	70	38.1(40)	15.9(16.4)	10(9)	60(50)	38(30)	PNEJ1235N	PTMA0405F	TW15S
160-07R/L	16	160	7	43	70	38.1(40)	15.9(16.4)	10(9)	60(50)	38(30)	PNEJ1240N	PTMA0406F	TW15S
160-08R/L	16	160	8	43	70	38.1(40)	15.9(16.4)	10(9)	60(50)	38(30)	PNEJ1245N	PTKA0407F	TW15S
160-09R/L	16	160	9	43	70	38.1(40)	15.9(16.4)	10(9)	60(50)	38(30)	PNEJ1250N	PTKA0408F	TW15S
160-10R/L	16	160	10	43	70	50.8(40)	15.9(16.4)	10(9)	60(50)	38(30)	PNEJ1255N	PTKA0409F	TW15S
160-11R/L	16	160	11	43	70	50.8(40)	15.9(16.4)	10(9)	60(50)	38(30)	PNEJ1260N	PTKA0410F	TW15S
160-12R/L	16	160	12	43	70	50.8(40)	15.9(16.4)	10(9)	60(50)	38(30)	PNEJ1265N	PTKA0411F	TW15S
160-13R/L	16	160	13	43	70	50.8(40)	15.9(16.4)	10(9)	60(50)	38(30)	PNEJ1270N	PTKA0412F	TW15S
160-14R/L	16	160	14	43	70	50.8(40)	15.9(16.4)	10(9)	60(50)	38(30)	PNEJ1275N	PTKA0413F	TW15S
200-06R/L	18	200	6	53	90	50.8(40)	19(16.4)	11(9)	65	38(30)	PNEJ1235N	PTMA0405F	TW15S
200-07R/L	18	200	7	53	90	50.8(40)	19(16.4)	11(9)	65	38(30)	PNEJ1240N	PTMA0406F	TW15S
200-08R/L	18	200	8	53	90	50.8(40)	19(16.4)	11(9)	65	38(30)	PNEJ1245N	PTKA0407F	TW15S
200-09R/L	18	200	9	53	90	50.8(40)	19(16.4)	11(9)	65	38(30)	PNEJ1250N	PTKA0408F	TW15S
200-10R/L	18	200	10	53	90	50.8(40)	19(16.4)	11(9)	65	38(30)	PNEJ1255N	PTKA0409F	TW15S
200-11R/L	18	200	11	53	90	50.8(40)	19(16.4)	11(9)	65	38(30)	PNEJ1260N	PTKA0410F	TW15S
200-12R/L	18	200	12	53	90	50.8(40)	19(16.4)	11(9)	65	38(30)	PNEJ1265N	PTKA0411F	TW15S
200-13R/L	18	200	13	53	90	50.8(40)	19(16.4)	11(9)	65	38(30)	PNEJ1270N	PTKA0412F	TW15S
200-14R/L	18	200	14	53	90	50.8(40)	19(16.4)	11(9)	65	38(30)	PNEJ1275N	PTKA0413F	TW15S

() Метрическая система

Рекомендуемые режимы резания

Обрабатываемые материалы	Режимы резания		Марка сплава
	V _p , м/мин	S _z , мм/зуб	
P	150 ~ 250	0.10 ~ 0.25	NCM325 PC3500 ST30A
	120 ~ 200	0.10 ~ 0.30	
	100 ~ 150	0.10 ~ 0.30	
M	80 ~ 180	0.10 ~ 0.25	PC9530 ST30A
	80 ~ 150	0.10 ~ 0.30	
K	130 ~ 200	0.10 ~ 0.35	PC6510 G10
	100 ~ 150	0.10 ~ 0.40	

Примечание

При установке СМП передняя поверхность пластины разворачивается в сторону стружечной канавки корпуса фрезы.
Закрепите пластину после того как убедитесь в полном ее прилегании к опорной поверхности.
Зазор между пластиной и опорной поверхностью во время крепления может привести к поломке инструмента.

SPS

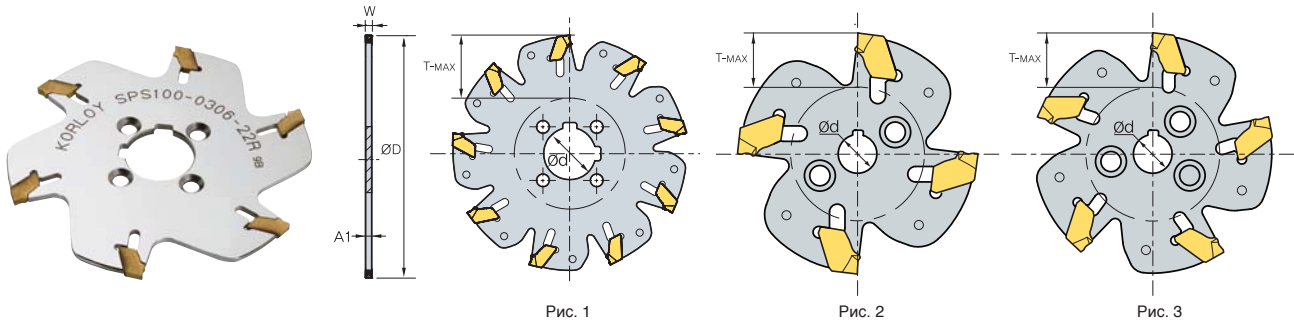

(мм)

Обозначение	ØD	W	T-маx	Ød	A1	Рис.	Insert	Оправки и планшайбы	
								WS	DF
SPS 050-0204-08R	50	2.2	11	8	1.8	2	SPFN 200	WS2528-M4	-
063-0205-10R	63	2.2	15.5	10	1.8	3		WS2532-M5	-
080-0207-22R/F	80	2.2	20 / 17	22	1.8	1		WS3240-M5	DF22-46
100-0209-22R/F	100	2.2	30 / 27	22	1.8	1	-	WS3240-M5	DF22-46
125-0211-32F	125	2.2	35	32	1.8	1		-	DF32-55
160-0214-32F	160	2.2	52.5	32	1.8	1		-	DF32-55
063-0305-10R	63	3	15.5	10	2.55	3	SPFN 300	WS2532-M5	-
080-0307-22R/F	80	3	20 / 17	22	2.55	1		WS3240-M5	DF22-46
100-0309-22R/F	100	3	30 / 27	22	2.55	1		WS3240-M5	DF22-46
125-0311-32F	125	3	35	32	2.55	1	-	-	DF32-55
160-0314-32F	160	3	52.5	32	2.55	1		-	DF32-55
200-0318-40F	200	3	60	40	2.55	1		-	DF40-80
080-0406-22R/F	80	4	20 / 17	22	3.4	1	SPFN 400	WS3240-M5	DF22-46
100-0408-22R/F	100	4	30 / 27	22	3.4	1		WS3240-M5	DF22-46
125-0410-32F	125	4	35	32	3.4	1		-	DF32-55
160-0413-32F	160	4	52.5	32	3.4	1	-	-	DF32-55
200-0417-40F	200	4	60	40	3.4	1		-	DF40-80

• () Метрическая система

WS() () Оправки с хвостовиком Weldon

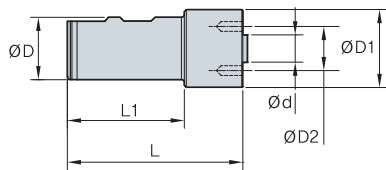

Обозначение	L	L ₁	D	D ₁	D ₂	d	Винт
WS2528-M4	110	85	25	28	18	8	PTKA0408
WS2532-M5	110	85	25	32	22	10	PTKA0515
WS3240-M5	120	90	32	40	32	22	PTKA0515

DF() () Планшайбы

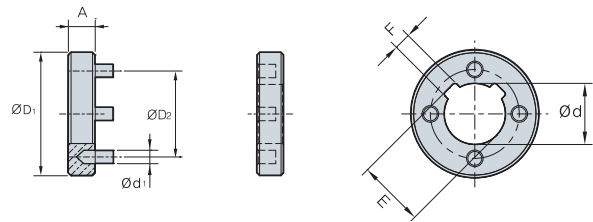

Обозначение	D ₁	D ₂	d	d ₁	A	E	F
DF22-46	46	32	22	5	10	24.1	6
DF32-55	55	45	32	6	10	34.8	8
DF40-80	80	63	40	11	12	43.5	10
DF50-110	110	80	50	14	14	53.6	12

Рекомендуемые режимы резания

Обрабатываемые материалы	Режимы резания		Марка сплава
	V _p , м/мин	S _z , мм/зуб	
P	150(100~200)	0.13~0.25	PC3500 PC3545
	120(80~170)	0.10~0.17	
M	160(120~200)	0.10~0.22	PC5300
K	110(70~150)	0.10~0.25	PC215K



Для изготовления пазов в деталях с радиусным закруглением
вершин различных размеров и ширины

Wind Mill *New*

- Оптимальное применение для изготовления закрытых пазов
- Уникальная геометрия карманов на вспомогательной кромке снижают нагрузки и увеличивают стойкость
- Специальная система зажима исключает неправильную установку и слом



• СМП



• Фреза в сборе

WFSP(M) - Плоский тип

WFSB(M) - Тип с фланцем



Обозначение торцевой фрезы

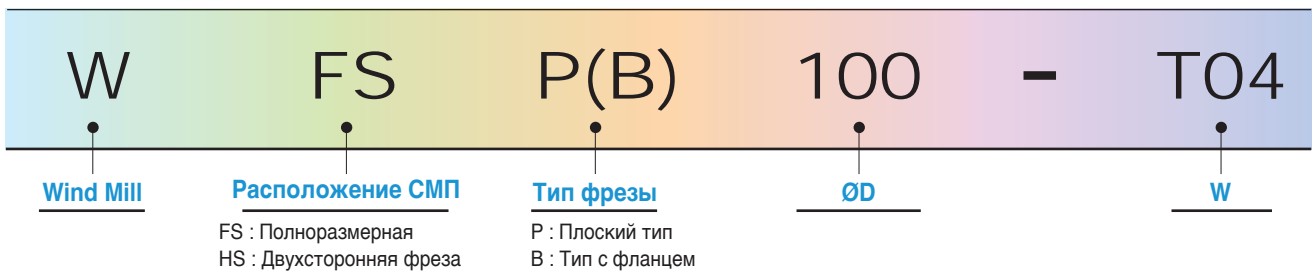

Система обозначения пластин



Свойства

- Идеальная геометрия для получения высокой шероховатости поверхности и стойкости



- Перпендикулярный паз

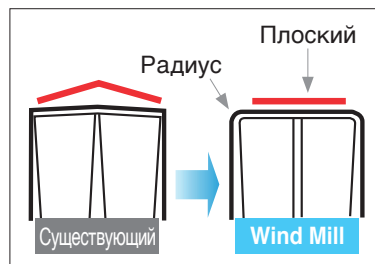

- Выступ на посадочной поверхности предотвращает не правильную установку СМП и излом

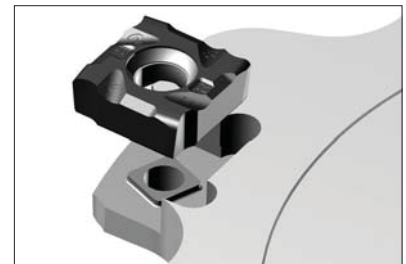

- Заготовки с различной шириной и возможными радиусами при вершине (R0.2~R2.0)

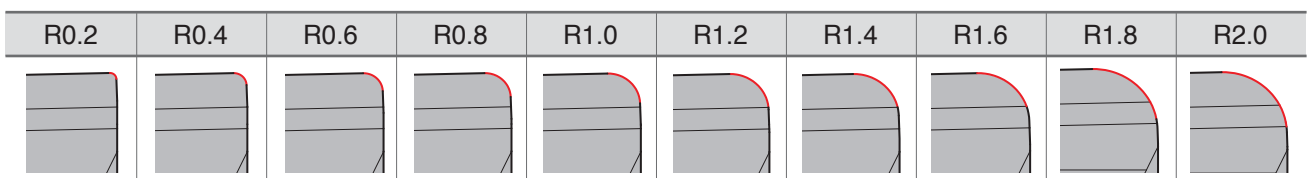

Пример использования

- **Заготовка** FCD500K
- **Условия резания** V_p , м/мин = 200
 S_z , мм/зуб = 0.2
 vf (мм/мин) = 600
 ap (мм) = 2~3
- **инструмента** KSF140R-T14-HM-2
SNHT1205408R/L-WX (PC5300)

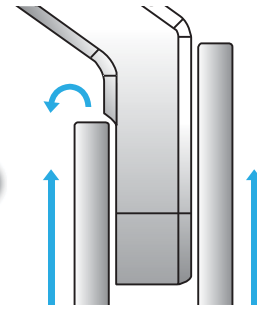
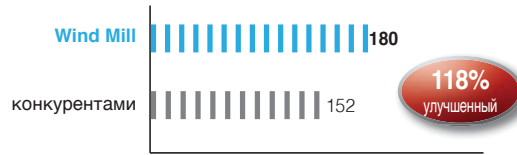

- **Заготовка** мягкая сталь
- **Условия резания** V_p , м/мин = 560
 S_z , мм/зуб = 0.09
 vf (мм/мин) = 750
 ap (мм) = 6
- **инструмента** WFSP178R/L-T06
SNHT1203508R/L-WX (PC5300)

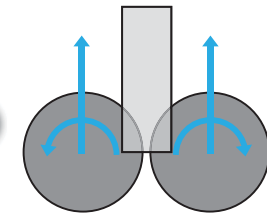
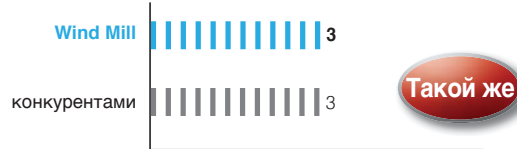

Рекомендуемые режимы резания

Обрабатываемые материалы	Режимы резания		Марка сплава
	V_p , м/мин	S_z , мм/зуб	
P	150 ~ 250	0.10 ~ 0.25	PC5300
	120 ~ 200	0.10 ~ 0.30	PC5300
	100 ~ 150	0.10 ~ 0.30	PC5300
M	100 ~ 180	0.10 ~ 0.25	PC5300
	80 ~ 150	0.10 ~ 0.30	PC5300
K	150 ~ 250	0.10 ~ 0.35	PC5300
	130 ~ 200	0.10 ~ 0.40	PC5300

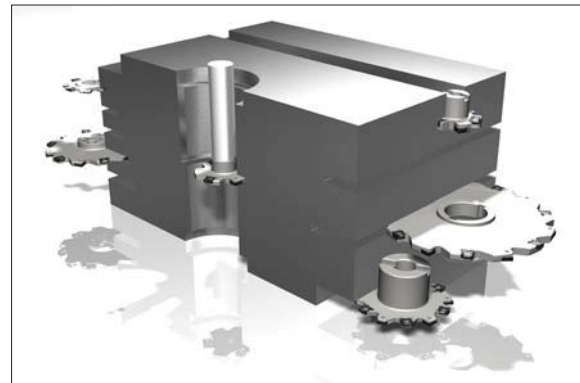

Применяемые СМП

СМП	Геометрические размеры			
	d	t	w	вершины R
SNHT1102308R/L-WX	11	2.3	4.0	0.2, 0.4, 0.6, 0.8, 1.0, 1.2, 1.4, 1.6
SNHT110308R/L-WX	11	3	5.0	0.2, 0.4, 0.6, 0.8, 1.0, 1.2, 1.4, 1.6
SNHT120308R/L-WX	12.7	3.25	5.5	0.2, 0.4, 0.6, 0.8, 1.0, 1.2, 1.4, 1.6, 1.8, 2.0
SNHT1203508R/L-WX	12.7	3.5	6.0	0.2, 0.4, 0.6, 0.8, 1.0, 1.2, 1.4, 1.6, 1.8, 2.0
SNHT120408R/L-WX	12.7	4	7.0	0.2, 0.4, 0.6, 0.8, 1.0, 1.2, 1.4, 1.6, 1.8, 2.0
SNHT1204508R/L-WX	12.7	4.54	8.0	0.2, 0.4, 0.6, 0.8, 1.0, 1.2, 1.4, 1.6, 1.8, 2.0
SNHT120508R/L-WX	12.7	5	9.0	0.2, 0.4, 0.6, 0.8, 1.0, 1.2, 1.4, 1.6, 1.8, 2.0
SNHT1205408R/L-WX	12.7	5.47	10.0	0.2, 0.4, 0.6, 0.8, 1.0, 1.2, 1.4, 1.6, 1.8, 2.0
SNHT120608R/L-WX	12.7	6	11.0	0.2, 0.4, 0.6, 0.8, 1.0, 1.2, 1.4, 1.6, 1.8, 2.0
SNHT1206508R/L-WX	12.7	6.5	12.0	0.2, 0.4, 0.6, 0.8, 1.0, 1.2, 1.4, 1.6, 1.8, 2.0
SNHT120708R/L-WX	12.7	7	13.0	0.2, 0.4, 0.6, 0.8, 1.0, 1.2, 1.4, 1.6, 1.8, 2.0
SNHT1207508R/L-WX	12.7	7.5	14.0	0.2, 0.4, 0.6, 0.8, 1.0, 1.2, 1.4, 1.6, 1.8, 2.0

- Пластины с вариантами закругления вершины R могут быть изготовлены в течении 2-3 месяцев
- Просьба уточнять стандартные размеры корпусов и СМП



WFSB(M) - Тип с фланцем New

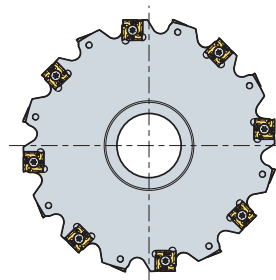
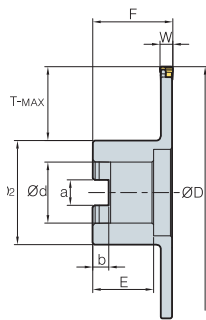

- AR : -2°
- RR : -12°

(мм)

Обозначение		ØD	W	T-MAX	ØD ₂	Ød	a	b	E	СМП	Винт	Ключ
WFSB(M) 080-T04	8	80	4	20	40	25.4(27)	6.35(7)	28.04(29.8)	8	SNHT11023R/L-WX	PTMA03503F	TW09S
080-T05	8	80	5	20	40	25.4(27)	6.35(7)	28.04(29.8)	8	SNHT1203R/L-WX	PTMA0404F	TW15S
080-T06	8	80	6	20	40	25.4(27)	6.35(7)	28.04(29.8)	8	SNHT12035R/L-WX	PTMA0404F	TW15S
100-T04	10	100	4	24	47	31.75(32)	7.94(8)	35.18(34.8)	8	SNHT11023R/L-WX	PTMA03503F	TW09S
100-T05	10	100	5	24	47	31.75(32)	7.94(8)	35.18(34.8)	8	SNHT1203R/L-WX	PTMA0404F	TW15S
100-T06	10	100	6	24	47	31.75(32)	7.94(8)	35.18(34.8)	8	SNHT12035R/L-WX	PTMA0404F	TW15S
100-T07	10	100	7	24	47	31.75(32)	7.94(8)	35.18(34.8)	10	SNHT1204R/L-WX	PTMA0405F	TW15S
100-T08	10	100	8	24	47	31.75(32)	7.94(8)	35.18(34.8)	10	SNHT12045R/L-WX	PTMA0406F	TW15S
100-T09	10	100	9	24	47	31.75(32)	7.94(8)	35.18(34.8)	12	SNHT1205R/L-WX	PTMA0407F	TW15S
100-T10	10	100	10	24	47	31.75(32)	7.94(8)	35.18(34.8)	12	SNHT12055R/L-WX	PTMA0408F	TW15S
125-T04	12	125	4	32	56	38.1(40)	9.53(10)	42.32(43.5)	8	SNHT11023R/L-WX	PTMA03503F	TW09S
125-T05	12	125	5	32	56	38.1(40)	9.53(10)	42.32(43.5)	8	SNHT1203R/L-WX	PTMA0404F	TW15S
125-T06	12	125	6	32	56	38.1(40)	9.53(10)	42.32(43.5)	8	SNHT12035R/L-WX	PTMA0404F	TW15S
125-T07	12	125	7	32	56	38.1(40)	9.53(10)	42.32(43.5)	10	SNHT1204R/L-WX	PTMA0405F	TW15S
125-T08	12	125	8	32	56	38.1(40)	9.53(10)	42.32(43.5)	10	SNHT12045R/L-WX	PTMA0406F	TW15S
125-T09	12	125	9	32	56	38.1(40)	9.53(10)	42.32(43.5)	12	SNHT1205R/L-WX	PTMA0407F	TW15S
125-T10	12	125	10	32	56	38.1(40)	9.53(10)	42.32(43.5)	12	SNHT12055R/L-WX	PTMA0408F	TW15S
160-T04	16	160	4	45	66	38.1(40)	9.53(10)	42.32(43.5)	8	SNHT11023R/L-WX	PTMA03503F	TW09S
160-T05	16	160	5	45	66	38.1(40)	9.53(10)	42.32(43.5)	8	SNHT1203R/L-WX	PTMA0404F	TW15S
160-T06	16	160	6	45	66	38.1(40)	9.53(10)	42.32(43.5)	8	SNHT12035R/L-WX	PTMA0404F	TW15S
160-T07	16	160	7	45	66	38.1(40)	9.53(10)	42.32(43.5)	10	SNHT1204R/L-WX	PTMA0405F	TW15S
160-T08	16	160	8	45	66	38.1(40)	9.53(10)	42.32(43.5)	10	SNHT12045R/L-WX	PTMA0406F	TW15S
160-T09	16	160	9	45	66	38.1(40)	9.53(10)	42.32(43.5)	12	SNHT1205R/L-WX	PTMA0407F	TW15S
160-T10	16	160	10	45	66	38.1(40)	9.53(10)	42.32(43.5)	12	SNHT12055R/L-WX	PTMA0408F	TW15S
160-T11	16	160	11	45	66	38.1(40)	9.53(10)	42.32(43.5)	14	SNHT1206R/L-WX	PTKA0410	TW15S
160-T12	16	160	12	45	66	38.1(40)	9.53(10)	42.32(43.5)	14	SNHT12065R/L-WX	PTKA0411	TW15S
160-T13	16	160	13	45	66	38.1(40)	9.53(10)	42.32(43.5)	16	SNHT1207R/L-WX	PTKA0412	TW15S
160-T14	16	160	14	45	66	38.1(40)	9.53(10)	42.32(43.5)	16	SNHT12075R/L-WX	PTKA0413	TW15S
200-T06	18	200	6	60	70	50.8(50)	12.7(12)	55.83(53.5)	8	SNHT12035R/L-WX	PTMA0404F	TW15S
200-T07	18	200	7	60	70	50.8(50)	12.7(12)	55.83(53.5)	10	SNHT1204R/L-WX	PTMA0405F	TW15S
200-T08	18	200	8	60	70	50.8(50)	12.7(12)	55.83(53.5)	10	SNHT12045R/L-WX	PTMA0406F	TW15S
200-T09	18	200	9	60	70	50.8(50)	12.7(12)	55.83(53.5)	12	SNHT1205R/L-WX	PTMA0407F	TW15S
200-T10	18	200	10	60	70	50.8(50)	12.7(12)	55.83(53.5)	12	SNHT12055R/L-WX	PTMA0408F	TW15S
200-T11	18	200	11	60	70	50.8(50)	12.7(12)	55.83(53.5)	14	SNHT1206R/L-WX	PTKA0410	TW15S
200-T12	18	200	12	60	70	50.8(50)	12.7(12)	55.83(53.5)	14	SNHT12065R/L-WX	PTKA0411	TW15S
200-T13	18	200	13	60	70	50.8(50)	12.7(12)	55.83(53.5)	16	SNHT1207R/L-WX	PTKA0412	TW15S
200-T14	18	200	14	60	70	50.8(50)	12.7(12)	55.83(53.5)	16	SNHT12075R/L-WX	PTKA0413	TW15S
250-T06	20	250	6	88	70	50.8(50)	12.7(12)	55.83(53.5)	8	SNHT12035R/L-WX	PTMA0404F	TW15S
250-T07	20	250	7	88	70	50.8(50)	12.7(12)	55.83(53.5)	10	SNHT1204R/L-WX	PTMA0405F	TW15S
250-T08	20	250	8	88	70	50.8(50)	12.7(12)	55.83(53.5)	10	SNHT12045R/L-WX	PTMA0406F	TW15S
250-T09	20	250	9	88	70	50.8(50)	12.7(12)	55.83(53.5)	12	SNHT1205R/L-WX	PTMA0407F	TW15S
250-T10	20	250	10	88	70	50.8(50)	12.7(12)	55.83(53.5)	12	SNHT12055R/L-WX	PTMA0408F	TW15S
250-T11	20	250	11	88	70	50.8(50)	12.7(12)	55.83(53.5)	14	SNHT1206R/L-WX	PTKA0410	TW15S
250-T12	20	250	12	88	70	50.8(50)	12.7(12)	55.83(53.5)	14	SNHT12065R/L-WX	PTKA0411	TW15S
250-T13	20	250	13	88	70	50.8(50)	12.7(12)	55.83(53.5)	16	SNHT1207R/L-WX	PTKA0412	TW15S
250-T14	20	250	14	88	70	50.8(50)	12.7(12)	55.83(53.5)	16	SNHT12075R/L-WX	PTKA0413	TW15S

• () Метрическая система



WFSP(M) - Плоский тип *New*

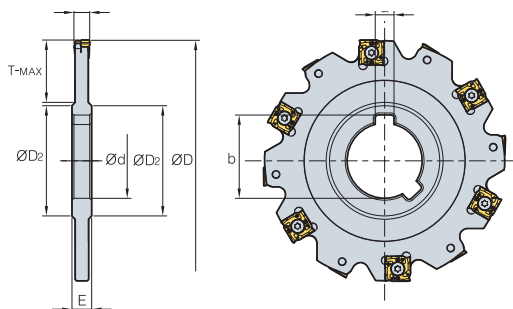

- AR : -2°
- RR : -12°

(MM)

Обозначение	⊙	ØD	W	T-MAX	ØD2	ød	a	b	E	СМП	Винт	Ключ
WFSP(M) 080-T04	8	80	4	20	40	25.4(27)	6.35(7)	28.04(29.8)	8	SNHT11023R/L-WX	PTMA03503F	TW09S
080-T05	8	80	5	20	40	25.4(27)	6.35(7)	28.04(29.8)	8	SNHT1203R/L-WX	PTMA0404F	TW15S
080-T06	8	80	6	20	40	25.4(27)	6.35(7)	28.04(29.8)	8	SNHT12035R/L-WX	PTMA0404F	TW15S
100-T04	10	100	4	24	47	31.75(32)	7.94(8)	35.18(34.8)	8	SNHT11023R/L-WX	PTMA03503F	TW09S
100-T05	10	100	5	24	47	31.75(32)	7.94(8)	35.18(34.8)	8	SNHT1203R/L-WX	PTMA0404F	TW15S
100-T06	10	100	6	24	47	31.75(32)	7.94(8)	35.18(34.8)	8	SNHT12035R/L-WX	PTMA0404F	TW15S
100-T07	10	100	7	24	47	31.75(32)	7.94(8)	35.18(34.8)	10	SNHT1204R/L-WX	PTMA0405F	TW15S
100-T08	10	100	8	24	47	31.75(32)	7.94(8)	35.18(34.8)	10	SNHT12045R/L-WX	PTMA0406F	TW15S
100-T09	10	100	9	24	47	31.75(32)	7.94(8)	35.18(34.8)	12	SNHT1205R/L-WX	PTMA0407F	TW15S
100-T10	10	100	10	24	47	31.75(32)	7.94(8)	35.18(34.8)	12	SNHT12055R/L-WX	PTMA0408F	TW15S
125-T04	12	125	4	32	56	38.1(40)	9.53(10)	42.32(43.5)	8	SNHT11023R/L-WX	PTMA03503F	TW09S
125-T05	12	125	5	32	56	38.1(40)	9.53(10)	42.32(43.5)	8	SNHT1203R/L-WX	PTMA0404F	TW15S
125-T06	12	125	6	32	56	38.1(40)	9.53(10)	42.32(43.5)	8	SNHT12035R/L-WX	PTMA0404F	TW15S
125-T07	12	125	7	32	56	38.1(40)	9.53(10)	42.32(43.5)	10	SNHT1204R/L-WX	PTMA0405F	TW15S
125-T08	12	125	8	32	56	38.1(40)	9.53(10)	42.32(43.5)	10	SNHT12045R/L-WX	PTMA0406F	TW15S
125-T09	12	125	9	32	56	38.1(40)	9.53(10)	42.32(43.5)	12	SNHT1205R/L-WX	PTMA0407F	TW15S
125-T10	12	125	10	32	56	38.1(40)	9.53(10)	42.32(43.5)	12	SNHT12055R/L-WX	PTMA0408F	TW15S
160-T04	16	160	4	45	66	38.1(40)	9.53(10)	42.32(43.5)	8	SNHT11023R/L-WX	PTMA03503F	TW09S
160-T05	16	160	5	45	66	38.1(40)	9.53(10)	42.32(43.5)	8	SNHT1203R/L-WX	PTMA0404F	TW15S
160-T06	16	160	6	45	66	38.1(40)	9.53(10)	42.32(43.5)	8	SNHT12035R/L-WX	PTMA0404F	TW15S
160-T07	16	160	7	45	66	38.1(40)	9.53(10)	42.32(43.5)	10	SNHT1204R/L-WX	PTMA0405F	TW15S
160-T08	16	160	8	45	66	38.1(40)	9.53(10)	42.32(43.5)	10	SNHT12045R/L-WX	PTMA0406F	TW15S
160-T09	16	160	9	45	66	38.1(40)	9.53(10)	42.32(43.5)	12	SNHT1205R/L-WX	PTMA0407F	TW15S
160-T10	16	160	10	45	66	38.1(40)	9.53(10)	42.32(43.5)	12	SNHT12055R/L-WX	PTMA0408F	TW15S
160-T11	16	160	11	45	66	38.1(40)	9.53(10)	42.32(43.5)	14	SNHT1206R/L-WX	PTKA0410	TW15S
160-T12	16	160	12	45	66	38.1(40)	9.53(10)	42.32(43.5)	14	SNHT12065R/L-WX	PTKA0411	TW15S
160-T13	16	160	13	45	66	38.1(40)	9.53(10)	42.32(43.5)	16	SNHT1207R/L-WX	PTKA0412	TW15S
160-T14	16	160	14	45	66	38.1(40)	9.53(10)	42.32(43.5)	16	SNHT12075R/L-WX	PTKA0413	TW15S
200-T06	18	200	6	60	70	50.8(50)	12.7(12)	55.83(53.5)	8	SNHT12035R/L-WX	PTMA0404F	TW15S
200-T07	18	200	7	60	70	50.8(50)	12.7(12)	55.83(53.5)	10	SNHT1204R/L-WX	PTMA0405F	TW15S
200-T08	18	200	8	60	70	50.8(50)	12.7(12)	55.83(53.5)	10	SNHT12045R/L-WX	PTMA0406F	TW15S
200-T09	18	200	9	60	70	50.8(50)	12.7(12)	55.83(53.5)	12	SNHT1205R/L-WX	PTMA0407F	TW15S
200-T10	18	200	10	60	70	50.8(50)	12.7(12)	55.83(53.5)	12	SNHT12055R/L-WX	PTMA0408F	TW15S
200-T11	18	200	11	60	70	50.8(50)	12.7(12)	55.83(53.5)	14	SNHT1206R/L-WX	PTKA0410	TW15S
200-T12	18	200	12	60	70	50.8(50)	12.7(12)	55.83(53.5)	14	SNHT12065R/L-WX	PTKA0411	TW15S
200-T13	18	200	13	60	70	50.8(50)	12.7(12)	55.83(53.5)	16	SNHT1207R/L-WX	PTKA0412	TW15S
200-T14	18	200	14	60	70	50.8(50)	12.7(12)	55.83(53.5)	16	SNHT12075R/L-WX	PTKA0413	TW15S
250-T06	20	250	6	88	70	50.8(50)	12.7(12)	55.83(53.5)	8	SNHT12035R/L-WX	PTMA0404F	TW15S
250-T07	20	250	7	88	70	50.8(50)	12.7(12)	55.83(53.5)	10	SNHT1204R/L-WX	PTMA0405F	TW15S
250-T08	20	250	8	88	70	50.8(50)	12.7(12)	55.83(53.5)	10	SNHT12045R/L-WX	PTMA0406F	TW15S
250-T09	20	250	9	88	70	50.8(50)	12.7(12)	55.83(53.5)	12	SNHT1205R/L-WX	PTMA0407F	TW15S
250-T10	20	250	10	88	70	50.8(50)	12.7(12)	55.83(53.5)	12	SNHT12055R/L-WX	PTMA0408F	TW15S
250-T11	20	250	11	88	70	50.8(50)	12.7(12)	55.83(53.5)	14	SNHT1206R/L-WX	PTKA0410	TW15S
250-T12	20	250	12	88	70	50.8(50)	12.7(12)	55.83(53.5)	14	SNHT12065R/L-WX	PTKA0411	TW15S
250-T13	20	250	13	88	70	50.8(50)	12.7(12)	55.83(53.5)	16	SNHT1207R/L-WX	PTKA0412	TW15S
250-T14	20	250	14	88	70	50.8(50)	12.7(12)	55.83(53.5)	16	SNHT12075R/L-WX	PTKA0413	TW15S

• () Метрическая система



Обработка с высокими подачами чугунов и легированных сталей.

Торцевые высокопроизводительные фрезы

- Обработка с высокими подачами чугунов и легированных сталей.
- Уменьшение биений за счет возможности регулировки СМП при базировании.
- Высокая технологичность установки СМП для диаметров до 160 мм, два способа установки СМП для диаметров от 200 мм.



Способы базирования СМП

► Для достижения заданной точности установки СМП могут применяться следующие схемы базирования:

Установочная оправка	Установочные ролики	Установочная плита
<p>Для фрез диаметром до 160 мм. Базирование фрез с адаптером осуществляется на специальной оправке. Возможность установки и регулирования СМП на фрезе в сборе с адаптером.</p>	<p>Для фрез диаметром свыше 200 мм. Высокая технологичность установки СМП благодаря 3 направляющим роликам возможность точного регулирования.</p>	<p>Простота в применении. Возможность точной установки СМП на станке, не снимая фрезу.</p>

Рекомендации по установке СМП с применением установочной оправки или установочных роликов.

1. Очистите инструмент и приспособление.
2. Установите индикатор на необходимую для измерений высоту.
3. Установите каждую пластину в гнездо и закрепите с усилием 2N.m.
4. Проведите измерения при помощи часового индикатора.
5. Определите общее биение
6. Пластины, не попадающие в допуск (для черновой обработки 10~20 мкм, для чистовой обработки 5~10 мкм.) необходимо переустановить.
7. Закрепите пластины с усилием 7-8N.m.
8. Окончательно измерьте биение пластин.

Примечание) Если винт затянуть слишком сильно, то это может увеличить биение из-за деформации фрезы. Для более точного зажима используйте динамометрический ключ.

адаптеры(Ø200-Ø450)

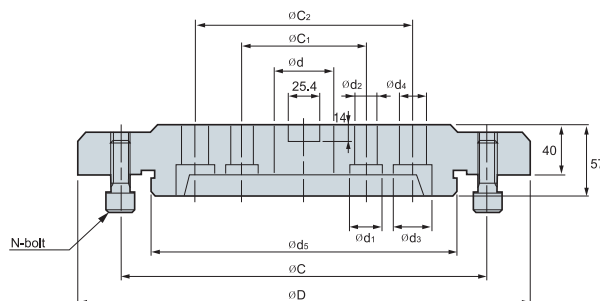

Обозначение	øD	ød	ød1	ød2	ød3	ød4	ød5	øC	øC1	øC2	N	Диаметр фрезы
APR 200	180	47.625	26	18	-	-	80	120	101.6	-	4	ø200
	250	47.625	26	18	-	-	120	170	101.6	-	4	ø250
315	295	47.625	26	18	32	22	180	230	101.6	177.8	6	ø315
355	335	63.50	26	18	32	22	220	270	101.6	177.8	6	ø355
400	370	63.50	26	18	32	22	250	300	101.6	177.8	8	ø400
450	420	63.50	26	18	32	22	300	350	101.6	177.8	8	ø450

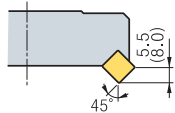
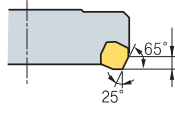
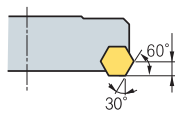
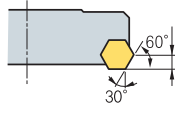
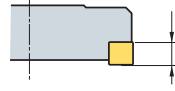
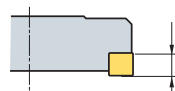

Геометрические характеристики и назначение фрез

Обозначение	Диаметр фрезы	Обрабатываемые материалы	Максимальная шероховатость обработанной поверхности	Угол в плане и максимальная глубина резания для фрез серии 5000	Осовой передний угол	Радиальный передний угол	Применяемые СМП
ANH4000 ANH5000	Ø100~Ø450	Чугуны Черновая обработка	25Z		-5°	-6°	SNCN1204ENN SNCN1504ENN
CDH4000 CDH5000	Ø100~Ø450	Алюминиевые сплавы Черновая обработка	18Z		+10°	+5°	SDCN42R SDCN53R
DEH5000	Ø100~Ø450	Чугуны Черновая и чистовая обработка	20Z		+14°	+6°	HECN090408FN
DPH5000	Ø100~Ø450	Алюминиевые сплавы Черновая обработка	12Z		+5°	-3°	HPEN090408 HPEN090408-WC
PNH4000 PNH5000	Ø125~Ø450	Чугуны Черновая обработка	12Z		-5°	-6°	SNEF435 SNEF535
PPH4000	Ø125~Ø450	Чугуны Черновая обработка	12Z		+5°	-5°	SPEN120416-WC

Рекомендуемые режимы резания

Обрабатываемые материалы	Режимы резания		Марка сплава	Примечание
	V _p , м/мин	S _z , мм/зуб		
Чугуны	100~230	0.05~0.20	PC6510	Тв. сплав с покрытием PVD
	80~150	0.05~0.20	H01,G10	Тв. сплав
Алюминиевые сплавы	400	0.10~0.30	PC6510	Тв. сплав с покрытием PVD
	400	0.05~0.20	H01,G10	Тв. сплав



Высокая эффективность применения при больших глубинах резания за счет значительной длины режущей кромки СМП.

Storm Mill

- Широкий диапазон применения.
- Использование 4 режущих кромок СМП (для корпусов исполнения R/L максимум 8 режущих кромок).
- Высокая эффективность применения при больших глубинах резания за счет значительной длины режущей кромки СМП.
- Широкий выбор марок сплава.
- Универсальность в применении СМП с различными типами режущей кромки (фаска / радиус).



Система обозначения фрез

S	Q	N	3	250	R	(2)	- 28Z
Фреза серии Storm mill	Угол в плане Q : 2° F : 5° A : 45° E : 15°	Величина заднего угла N : 0°	Диаметр вписанной окружности 3 : 9.525mm 4 : 12.7mm	Диаметр фрезы ММ	Исполнение R : Правый L : Левый	Тип фрезы Не указано: стандартный тип Величина заднего угла 2: быстросменный тип	
							Количество зубьев

Фреза в сборе

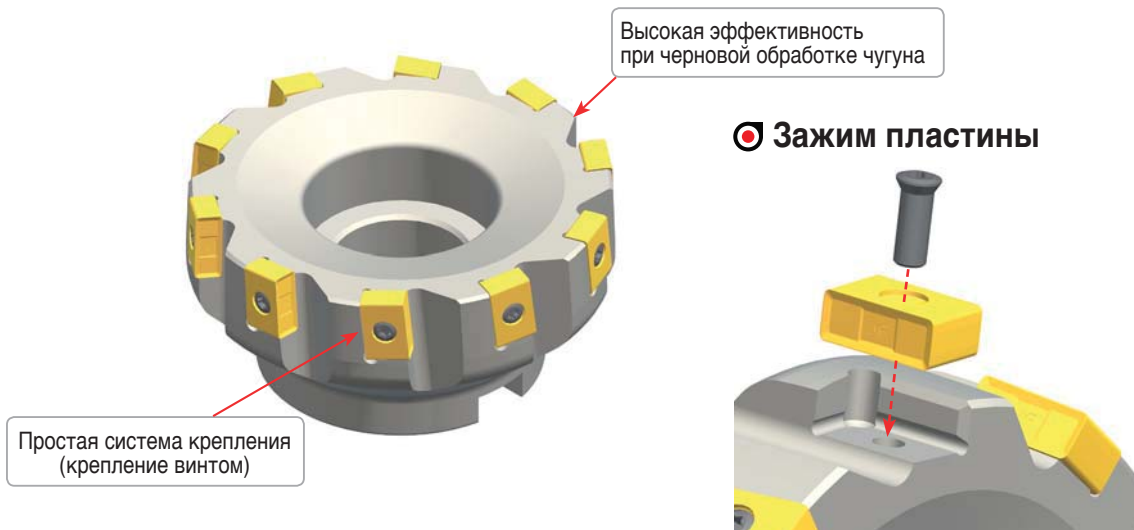

Рекомендуемые режимы резания

Обозначение Марка сплава	Серые чугуны GC		Ковкие чугуны GCD	
	Vp, м/мин	Sz, мм/зуб	Vp, м/мин	Sz, мм/зуб
PC3500	150~250	0.08~0.28	100~180	0.08~0.28
PC6510	150~300	0.10~0.28	100~200	0.10~0.28
PC3545	150~250	0.08~0.22	100~180	0.08~0.22
H01	100~200	0.08~0.22	70~140	0.08~0.22
G10	90~120	0.08~0.28	60~130	0.08~0.28



Оптимальная фреза для обработки стали и чугунов с легкой регулировкой по биению

Shave Mill

- Регулируемый диапазон (Регулируемый диапазон: 0,1 мм, Точность регулировки: в пределах 2 мкм)
- СМП типа Wiper имеют 8 рабочих углов, что снижает стоимость обработки и дают отличную шероховатость поверхности
- Сплав с высокой прочностью и износостойкостью обеспечивают длительный срок службы
- Сплавы КНБ обеспечивают великолепную чистоту поверхности

Система обозначения фрез

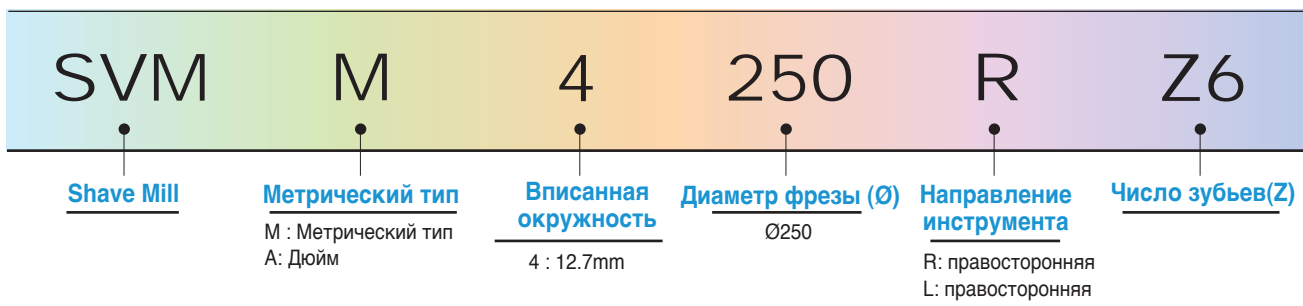

Система обозначения сменных пластин

■ Карбид

Тип вершины R	SNEU120420-MF
Тип фаски	SNEU1204ANN-MF
Зачистной тип	SNEU1204-WMF

■ cBN

SNEU1204-TBW
T : Nagaland B : КНБ W : Wiper

Свойства



Регулировка

- Регулируемый диапазон: 0,1 мм
- Точность регулировки: меньше 2мкм
- Настройка: легко и просто



Особенности пластин



SNEU120420-MF

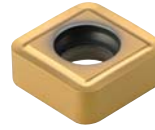

Тип вершины R

SNEU1204ANN-MF



Тип фаски

SNEU1204-WMF



Для малых сил резания

SNEU1204-TBW



Wiper для высокоскоростной обработки

Рекомендуемые режимы резания

Заготовка	Режимы резания			Сплав
	V _p , м/мин	S _z , мм/зуб	а _p (мм)	
P	150~250	0.05 ~ 0.2	~ 0.5	PC3500
K	150~300	0.05 ~ 0.3	~ 0.5	PC6510
	600~1000	0.05 ~ 0.2	~ 0.5	DBN920

Пример использования 1

- Заготовка : Головка блока цилиндров (плоскость)
- Режимы резания : v_c=200, f_z=0.15, а_p=0.5, Dry
- Инструмент: Шабрящая фреза - SVMM4250R
СМП - PC6510 SNEU120420-MF

Пример использования 2

- Заготовка : FC25(HB250)
Головка блока цилиндров (плоскость)
- Режимы резания : v_c=700, f_z=0.1, а_p=0.5, Без СОЖ
- Инструмент: Шабрящая фреза - SVMM4160R
СМП - DBN920 SNEU1204-сBN

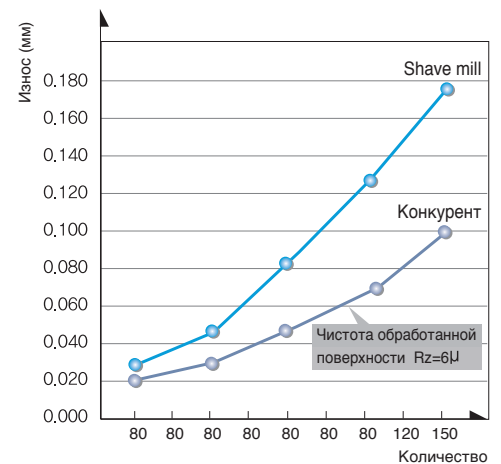

Результаты

	Стойкость инструмента	Чистота обработанной поверхности	Производительность
Shave mill	250pcs	Rz=3 μ	High
Конкурент	180pcs	Rz=3.5 μ	Normal

- ▶ Шабрящие фрез KORLOY повышают в два раза производительность, шероховатость поверхности, легко регулируются и увеличивается срок службы по сравнению с конкурентами.



Высокая стойкость СМП за счет специальной марки сплава имеющей высокую механическую прочность.

Shave Mill Ultra

- Высокое качество чистовой обработки даже в тяжелых условиях резания.
- Простота и надежность винтового крепления СМП.
- Низкая шероховатость обработанной поверхности благодаря применению СМП с режущими кромками типа «Wiper».
- Высокая стойкость СМП за счет специальной марки сплава имеющей высокую механическую прочность.
- Возможность выбора различных типов фрез: экономичного — стандартного и регулируемого — В.

Система обозначения фрез

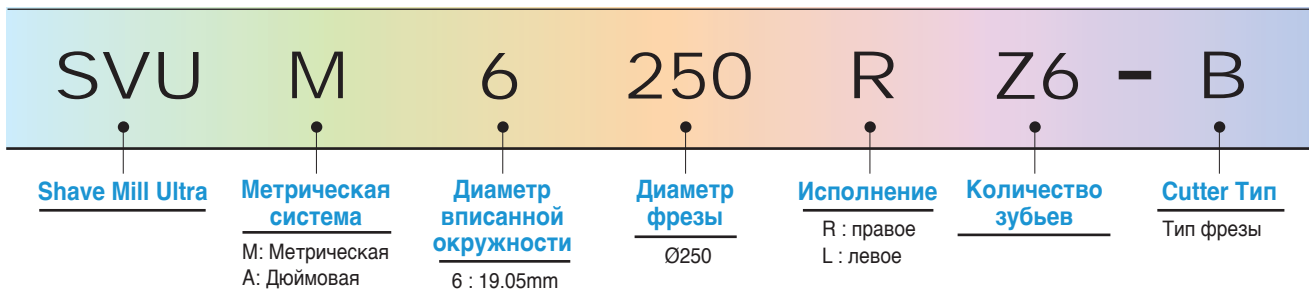

Система обозначение СМП

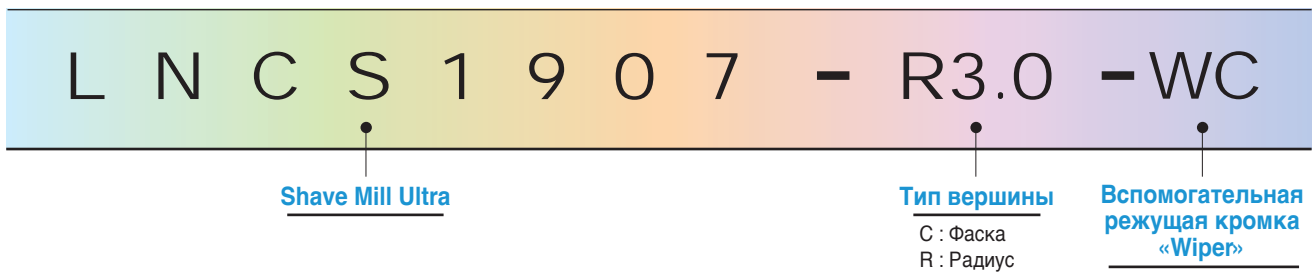

Характеристики

Стандартный тип



Высокая жесткость и надежность винтового крепления

Высокое качество обработанной поверхности достигается при установке только 1 СМП и глубине резания от 0,03 мм.



Положительная геометрии передней поверхности способствует уменьшению силы резания

Экономичность применения благодаря 4 ем режущим кромкам

Высокое качество обработанной поверхности за счет режущих кромок типа «Wiper»

Регулируемый тип—В



Легкость регулировки и высокая эксплуатационная надежность кассеты

Характеристики системы регулировки

Диапазон регулирования: 1,0 мм

Шаг: минимальное значение 2 мкм

Рекомендуемые режимы резания

Обрабатываемые материалы	Режимы резания			Количество рабочих зубьев	Марка сплава
	Vp, м/мин	Sz, мм/зуб	ap(мм)		
P	150~250	0.05~0.20	~0.50	Full use	PC3500
	150~250	2~5	~0.03	1use	
K	150~300	0.05~0.20	~0.50	Full use	PC6510
	150~300	2~5	~0.03	1use	



Специальные фрезы для черновой обработки чугуна.

Cube Mill



- Специальные фрезы для черновой обработки чугуна.
- Наличие 8 режущих кромок СМП (для фрез правого и левого исполнения возможно использование 16 режущих кромок СМП, фреза R/L).
- Снижения сил резания за счет положительной геометрии, передней поверхности СМП.
- Обеспечение высокой стойкости за счет широкого выбора марок твердого сплава и стружколомов СМП.
- Два вида пластин (с закругленными кромками и R – типа) для одного вида фрез.

Система обозначения фрез

CBM	E	3	250	R	(2) – 28Z
Фреза серии CBM : CUBE MILL	Угол в плане Q : 88° C : 65° F : 85° A : 45° E : 75°	Диаметр фрезы 3 : 9.525 4 : 12.7	Диаметр вписанной окружности Ø250	Исполнение R : правое L : левое	Тип фрезы Не указано: стандартный тип 2 : быстросменный тип

СМП (правое –R/ левое –L исполнение)



Диаметры фрез

Диаметры фрез	Универсальные	Универсальные
	Ø80~315 мм 3 1/4~12 1/2 дюйм	Ø200~450 мм 8~18 дюйм

Угол в плане : 2°, 5°, 15°, 25°, 45°

Фрезы



При установке СМП обеспечивается положительный передний угол

Простая система крепления (крепление винтом)

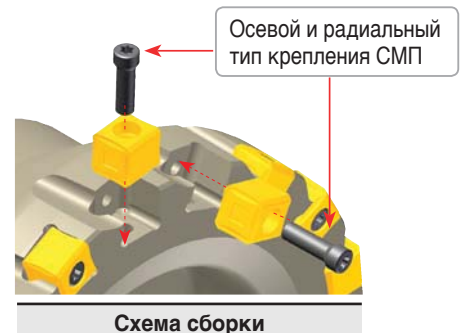

Комплектующие

 Cube mill 3000	Винт	Ключ
	 FTGA0417CBM	 TW15 - 100
	ETGA0520CBM	TW20 - 100



Высокая эффективность применения для высокоскоростной обработки чугуна.

Couple Mill

- Высокая эффективность применения для высокоскоростной обработки чугуна. Специальная конструкция алюминиевой планшайбы и стального корпуса фрезы.
- Снижение нагрузки на шпиндель станка и обеспечение высокой эксплуатационной надежности благодаря уменьшению веса фрезы за счет алюминиевой планшайбы.
- Применим для фрез серии Cube, Dura, Storm

Система обозначения фрез серии «Cube-Coupe»

CBM	E	3	355	R	28Z	CP
Фреза серии	Угол в плане	Диаметр вписанной окружности	Диаметр фрезы	Исполнение	Количество зубьев	Couple Mill
CBM : CUBE MILL	Q : 2° C : 25° F : 5° A : 45° E : 15°	3 : 9.525 4 : 12.7	Ø355	R : правое L : левое	28Z : 28	

Система обозначения фрез серии «Storm-Coupe»

S	Q	N	3	355	R	28Z	CP
Фреза серии	Угол в плане	Величина заднего угла	Диаметр вписанной окружности	Диаметр фрезы	Исполнение	Количество зубьев	Couple Mill
S : STORM MILL	Q : 2° E : 15° F : 5° A : 45°	N : 0°	3 : 9.525мм 4 : 12.7мм	Ø355	R : правое L : левое	28Z : 28	

Схема сборки фрезы

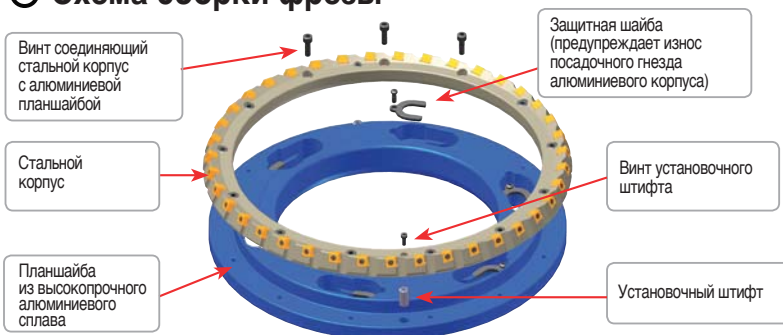

Диаметры фрез

Диаметры фрез	Метрическая система Inch	Ø355~450мм
	Дюймовая система	14 1/4~18 Дюйм

Комплектующие

	Винт	Ключ	Ключ	Винт корпуса	Винт штифта	Установочный штифт
CUBE-COUPLE 3000 Тип 4000 Тип	FTGA0417CBM ETGA0520CBM	TW15-100 TW20-100	-	BHA0616 BHA0620	MHBO410	PN1019-DRV
STORM-COUPLE 3000 Тип	FTNA0513	-	TW15S	-	-	-



Технические характеристики фрез серии «Couple Mill»

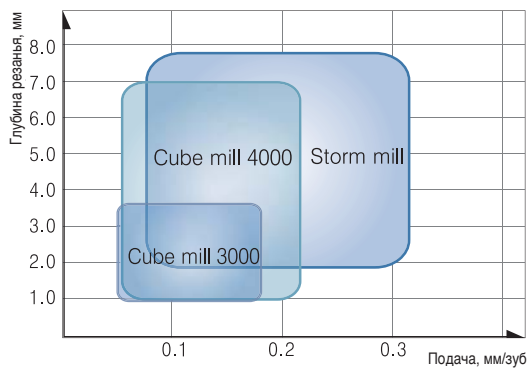

Рекомендуемые режимы резания

CUBE MILL		Серые чугуны		Ковкие чугуны	
		V, м/мин	Sz, мм/зуб	V, м/мин	Sz, мм/зуб
PVD	PC6510	150 ~ 300	0.08 ~ 0.18	100 ~ 200	0.08 ~ 0.18
	PC215K	120 ~ 210	0.05 ~ 0.18	80 ~ 150	0.05 ~ 0.18
Тв. сплав	G10	90 ~ 120	0.05 ~ 0.18	60 ~ 130	0.05 ~ 0.18

Применяемые оправки и посадочные фланцы

Обозначение		Оправки и посадочные фланцы		
		Оправка с хвостовиком BT	Оправка с хвостовиком NT	Посадочный фланец
CBMQ	3080R/L -00Z	BT□□-FMA25.4-□□	NT*(□□(M/U)-FMA25.4-25	
(CBMF)	3100R/L -00Z	BT□□-FMA31.75-□□	NT*(□□(M/U)-FMA31.75-□□	
(CBME)	3125R/L -00Z	BT□□-FMA38.1-□□	NT*(□□(M/U)-FMA38.1-□□	
(CBMC)	3160R/L -00Z	BT□□-FMA50.8-□□	NT*(□□(M/U)-FMA50.8-□□	
(CBMA)	3200R/L -00Z	BT□□-FMA47.625-□□	NT*(□□(M/U)-FMA47.625-25, KCP-8***	
	3250R/L -00Z	BT□□-FMA47.625-□□	KNT*(□□(M/U)-FMA47.625-25, KCP-8***	
	3315R/L -00Z		KCP-8*** (Centering Plug)	
	3200R/L2 -00Z			APR200
	3250R/L2 -00Z			APR250
	3315R/L2 -00Z			APR315
	3355R/L2 -00Z			APR355
	3400R/L2 -00Z			APR400
	3450R/L2 -00Z			APR450
SQN	3080R/L -00Z	BT□□-FMA25.4-□□	NT*(□□(M/U)-FMA25.4-25	
(SFN)	3100R/L -00Z	BT□□-FMA31.75-□□	NT*(□□(M/U)-FMA31.75-□□	
(SEN)	3125R/L -00Z	BT□□-FMA38.1-□□	NT*(□□(M/U)-FMA38.1-□□	
(SAN)	3160R/L -00Z	BT□□-FMA50.8-□□	NT*(□□(M/U)-FMA50.8-□□	
	3200R/L -00Z	BT□□-FMA47.625-□□	NT*(□□(M/U)-FMA47.625-25, KCP-8***	
	3250R/L -00Z	BT□□-FMA47.625-□□	NT*(□□(M/U)-FMA47.625-25, KCP-8***	
	3315R/L -00Z		KCP-8*** (Centering Plug)	
	3200R/L2 -00Z			APR200
	3250R/L2 -00Z			APR250
	3315R/L2 -00Z			APR315
	3355R/L2 -00Z			APR355
	3400R/L2 -00Z			APR400
	3450R/L2 -00Z			APR450

* □□ -No BT / ** □□ -No NT / *** Для больших диаметров



ANH4000



Рис. 1



Рис. 2

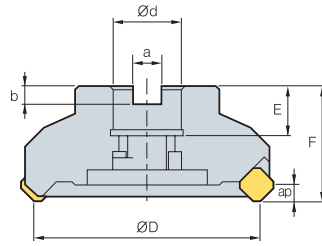

AA
45°
• AR : 5°
• RR : -6°

(мм)

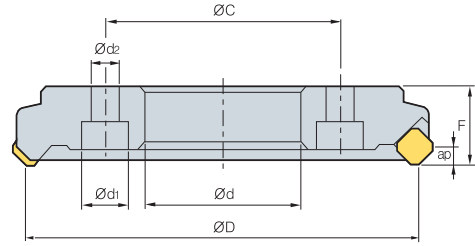
Обозначение		$\varnothing D$	$\varnothing d$	$\varnothing d_1$	$\varnothing d_2$	a	b	E	F	$\varnothing C$	ap		Рис.
ANH 4100R/L	8	100	31.75	-	-	12.7	8	22	50	-	5.5	2.5	1
4125R/L	10	125	38.1	-	-	15.9	10	27	63	-	5.5	4.7	1
4160R/L	14	160	50.8	-	-	19.0	11	27	63	-	5.5	7.3	1
4200R/L	18	200	80	24	14	-	-	-	40	120	5.5	7	2
4250R/L	24	250	120	30	18	-	-	-	40	170	5.5	9.6	2
4315R/L	30	315	180	30	18	-	-	-	40	230	5.5	12.9	2
4355R/L	34	355	220	30	18	-	-	-	40	270	5.5	15.5	2
4400R/L	38	400	250	30	18	-	-	-	40	300	5.5	18.8	2
4450R/L	44	450	300	30	18	-	-	-	40	350	5.5	22.2	2

Применяемые СМП

SNCN

SNKN



Обозначение	Тв. сплав с покрытием								Кермет			Тв. сплав				Стр.		
	NCM325	NCM335	NC5330	PC3500	PC5300	PC3545	PC9530	PC6510	PC215K	PD2000	CN2000	CN20	CN30	H01	G10		ST30A	ST20
SNCN 1204ENN	●														●	●	●	E17
SNKN 1204ENN								●										E19

Применяемые оправки

Обозначение	Оправка	
ANH 100R/L	NT*□□ (M/U)-FMA31.75-□□	-
125R/L	NT*□□ (M/U)-FMA38.1-□□	-
160R/L	NT*□□ (M/U)-FMA50.8-□□	-
200R/L	-	APR200
250R/L	-	APR250
315R/L	-	APR315
355R/L	-	APR355
400R/L	-	APR400
450R/L	-	APR450

Рекомендуемые режимы резания

Обрабатываемые материалы	Режимы резания		Марка сплава
	V _p , м/мин	S _z , мм/зуб	
K	100 ~ 200	0.05 ~ 0.30	PC6510 H01,G10
	80 ~ 150	0.10 ~ 0.30	

Комплектующие



WANH4N DHA0821F HW40

Схема сборки

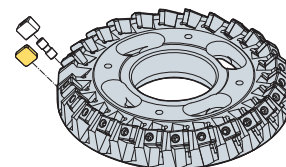

ANH5000



Рис. 1



Рис. 2

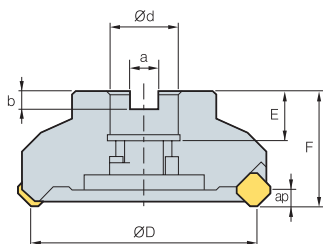

AA
45°
• AR : 5°
• RR : -6°

(мм)

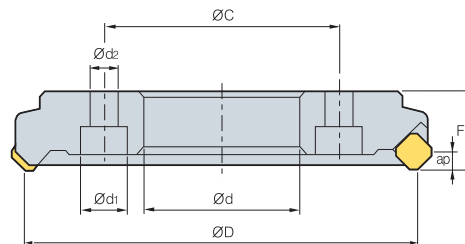
Обозначение		ØD	Ød	Ød ₁	Ød ₂	a	b	E	F	ØC	ap		Рис.
ANH 5100R/L	8	100	31.75	-	-	12.7	8	22	50	-	8	2.6	1
5125R/L	10	125	38.1	-	-	15.9	10	27	63	-	8	5	1
5160R/L	14	160	50.8	-	-	19.0	11	27	63	-	8	7.5	1
5200R/L	18	200	80	24	14	-	-	-	40	120	8	7	2
5250R/L	24	250	120	30	18	-	-	-	40	170	8	9.6	2
5315R/L	30	315	180	30	18	-	-	-	40	230	8	12.9	2
5355R/L	34	355	220	30	18	-	-	-	40	270	8	15.5	2
5400R/L	38	400	250	30	18	-	-	-	40	300	8	18.8	2
5450R/L	44	450	300	30	18	-	-	-	40	350	8	22.2	2

Применяемые СМП

SNCN



SNKN



Обозначение	Тв. сплав с покрытием								Кермет			Тв. сплав				Стр.		
	NCM325	NCM335	NC5330	PC3500	PC5300	PC3545	PC9530	PC6510	PC215K	PD2000	CN2000	CN20	CN30	H01	G10		ST30A	ST20
SNCN 1504ENN																		E17
SNKN 1504ENN	●																	E19

Применяемые оправки

Обозначение	Оправка	
ANH 100R/L	NT*□□ (M/U)-FMA31.75-□□	-
125R/L	NT*□□ (M/U)-FMA38.1-□□	-
160R/L	NT*□□ (M/U)-FMA50.8-□□	-
200R/L	-	APR200
250R/L	-	APR250
315R/L	-	APR315
355R/L	-	APR355
400R/L	-	APR400
450R/L	-	APR450

Рекомендуемые режимы резания

Обрабатываемые материалы	Режимы резания		Марка сплава
	V _p , м/мин	S _z , мм/зуб	
K	100 ~ 200	0.05 ~ 0.30	PC6510 H01, G10
	80 ~ 150	0.10 ~ 0.30	

Комплектующие



WANH5N



DHA0821F



HW40

Схема сборки

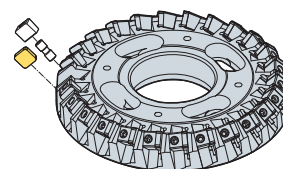

CDH4000



Рис. 1



Рис. 2

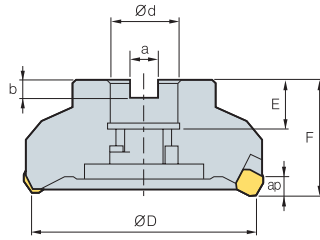

AA
65°
• AR : 10°
• RR : 5°

(мм)

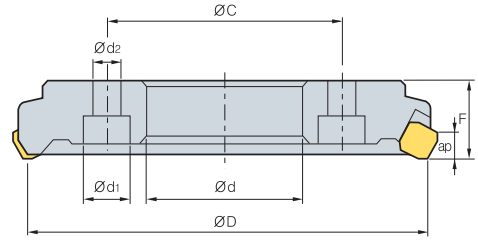
Обозначение		$\varnothing D$	$\varnothing d$	$\varnothing d_1$	$\varnothing d_2$	a	b	E	F	$\varnothing C$	ap		Рис.
CDH 4100R/L	8	100	31.75	-	-	12.7	8	22	50	-	6	2.3	1
4125R/L	10	125	38.1	-	-	15.9	10	27	63	-	6	4.4	1
4160R/L	14	160	50.8	-	-	19.0	11	27	63	-	6	6.8	1
4200R/L	18	200	80	24	14	-	-	-	40	120	6	6.7	2
4250R/L	24	250	120	30	18	-	-	-	40	170	6	9.1	2
4315R/L	30	315	180	30	18	-	-	-	40	230	6	12.3	2
4355R/L	34	355	220	30	18	-	-	-	40	270	6	14.8	2
4400R/L	38	400	250	30	18	-	-	-	40	300	6	18.1	2
4450R/L	44	450	300	30	18	-	-	-	40	350	6	21.3	2

Применяемые СМП

SDCN



Обозначение	Тв. сплав с покрытием								Кермет			Тв. сплав				Стр.		
	NCM325	NCM335	NC5330	PC3500	PC5300	PC3545	PC9530	PC6510	PC215K	PD2000	CN2000	CN20	CN30	H01	G10		ST30A	ST20
SDCN 42R 42L														●				E13

Применяемые оправки

Обозначение	Оправка	
CDH 100R/L	NT*□□(M/U)-FMA31.75-□□	-
125R/L	NT*□□(M/U)-FMA38.1-□□	-
160R/L	NT*□□(M/U)-FMA50.8-□□	-
200R/L	-	APR200
250R/L	-	APR250
315R/L	-	APR315
355R/L	-	APR355
400R/L	-	APR400
450R/L	-	APR450

Рекомендуемые режимы резания

Обрабатываемые материалы	Режимы резания		Марка сплава
	V _p , м/мин	S _z , мм/зуб	
K	100 ~ 200	0.05 ~ 0.30	PC6510 H01,G10
	80 ~ 150	0.10 ~ 0.30	

Комплектующие



∅100-∅160	WCDH4R1L1	DHA0821F	HW40
∅200-∅450	WCDH4R/L		

Схема сборки

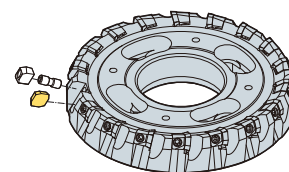

CDH5000



Рис. 1



Рис. 2

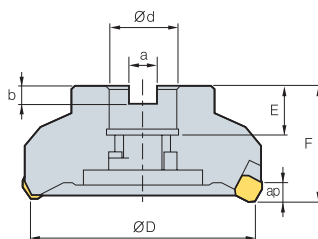

AA
65°
• AR : 10°
• RR : 5°

(мм)

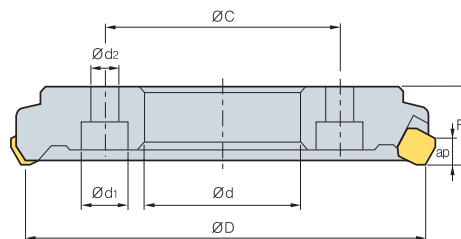
Обозначение		ØD	Ød	Ød ₁	Ød ₂	a	b	E	F	ØC	ap		Рис.
CDH 5100R/L	08	100	31.75	-	-	12.7	8	22	50	-	7	2.3	1
5125R/L	10	125	38.1	-	-	15.9	10	27	63	-	7	4.4	1
5160R/L	14	160	50.8	-	-	19.0	11	27	63	-	7	6.8	1
5200R/L	18	200	80	24	14	-	-	-	40	120	7	6.6	2
5250R/L	24	250	120	30	18	-	-	-	40	170	7	9.1	2
5315R/L	30	315	180	30	18	-	-	-	40	230	7	12.2	2
5355R/L	34	355	220	30	18	-	-	-	40	270	7	14.7	2
5400R/L	38	400	250	30	18	-	-	-	40	300	7	18	2
5450R/L	44	450	300	30	18	-	-	-	40	350	7	21.2	2

Применяемые СМП

SDCN



Обозначение	Тв. сплав с покрытием								Кермет			Тв. сплав				Стр.	
	NCM325	NCM335	NC5330	PC3500	PC5300	PC3545	PC9530	PC6510	PC215K	PD2000	CN2000	CN20	CN30	H01	G10		ST30A
SDCN 53R 53L																	E12

Применяемые оправки

Обозначение	Оправка	
CDH 100R/L	NT*□□ (M/U)-FMA31.75-□□	-
125R/L	NT*□□ (M/U)-FMA38.1-□□	-
160R/L	NT*□□ (M/U)-FMA50.8-□□	-
200R/L	-	APR200
250R/L	-	APR250
315R/L	-	APR315
355R/L	-	APR355
400R/L	-	APR400
450R/L	-	APR450

Рекомендуемые режимы резания

Обрабатываемые материалы	Режимы резания		Марка сплава
	V _p , м/мин	S _z , мм/зуб	
К	100 ~ 200	0.05 ~ 0.30	PC6510 H01,G10
	80 ~ 150	0.10 ~ 0.30	

Комплектующие

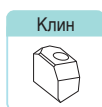

Ø100-Ø160	WCDH5R1L1	DHA0821F	HW40
Ø200-Ø450	WCDH5R/L		

Схема сборки

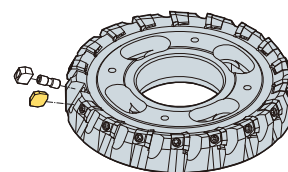

DEH5000



Рис. 1



Рис. 2

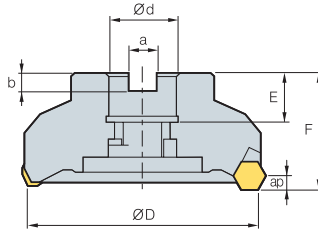

AA
60°

• AR : 14°
• RR : 6°

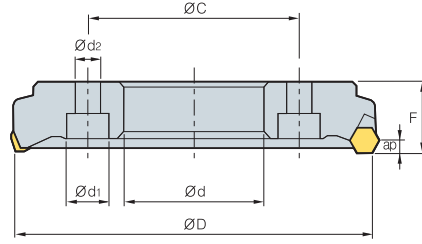
(мм)

Обозначение		$\varnothing D$	$\varnothing d$	$\varnothing d_1$	$\varnothing d_2$	a	b	E	F	$\varnothing C$	ap	$\frac{\rho}{kg}$	Рис.
DEH 5100R/L	6	100	31.75	-	-	12.7	8	22	50	-	7	2.3	1
5125R/L	7	125	38.1	-	-	15.9	10	27	63	-	7	4.4	1
5160R/L	8	160	50.8	-	-	19.0	11	27	63	-	7	6.3	1
5200R/L	12	200	80	24	14	-	-	-	40	120	7	6.5	2
5250R/L	14	250	120	30	18	-	-	-	40	170	7	9.1	2
5315R/L	18	315	180	30	18	-	-	-	40	230	7	12.1	2
5355R/L	20	355	220	30	18	-	-	-	40	270	7	14.8	2
5400R/L	24	400	250	30	18	-	-	-	40	300	7	17.8	2
5450R/L	28	450	300	30	18	-	-	-	40	350	7	21	2

Применяемые СМП

HECN



Обозначение	Тв. сплав с покрытием								Кермет			Тв. сплав		Стр.			
	NCM325	NCM335	NC5330	PC-3500	PC5300	PC-3545	PC9530	PC6510	PC215K	PD2000	CN2000	CN20	CN30		H01	G10	ST30A
HECN 090408FN																	
090408SN																	
090408TN																	

Применяемые оправки

Обозначение	Оправка
DEH 5100R/L	NT*□□ (M/U)-FMA31.75-□□
5125R/L	NT*□□ (M/U)-FMA38.1-□□
5160R/L	NT*□□ (M/U)-FMA50.8-□□
5200R/L	- APR200
5250R/L	- APR250
5315R/L	- APR315
5355R/L	- APR355
5400R/L	- APR400
5450R/L	- APR450

Рекомендуемые режимы резания

Обрабатываемые материалы	Режимы резания		Марка сплава
	V _p , м/мин	S _z , мм/зуб	
K	100 ~ 200	0.05 ~ 0.30	PC6510 H01,G10
	80 ~ 150	0.10 ~ 0.30	

Комплектующие



Ø100-Ø200	WDEHR-1/L-1	DHA0821F	HW40
Ø250-Ø450	WDEHR/L		

Схема сборки

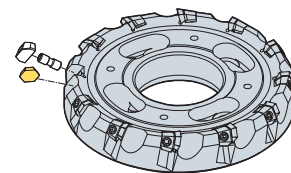

DPH5000



Рис. 1



Рис. 2

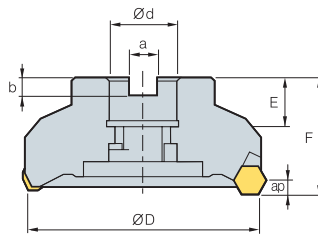

AA
60°

• AR : 5°
• RR : -3°

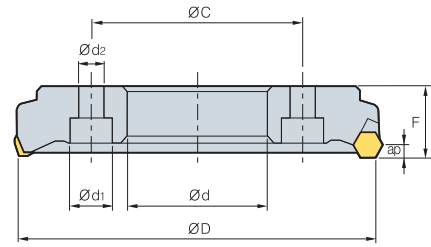
(мм)

Обозначение		$\varnothing D$	$\varnothing d$	$\varnothing d_1$	$\varnothing d_2$	a	b	E	F	$\varnothing C$	ap		Рис.
DPH 5100R/L	8	100	31.75	-	-	12.7	8	22	50	-	7	2.3	1
5125R/L	10	125	38.1	-	-	15.9	10	27	63	-	7	4.4	1
5160R/L	14	160	50.8	-	-	19.0	11	27	63	-	7	6.7	1
5200R/L	18	200	80	24	14	-	-	-	40	120	7	6.5	2
5250R/L	24	250	120	30	18	-	-	-	40	170	7	9	2
5315R/L	30	315	180	30	18	-	-	-	40	230	7	12	2
5355R/L	34	355	220	30	18	-	-	-	40	270	7	14.5	2
5400R/L	38	400	250	30	18	-	-	-	40	300	7	17.7	2
5450R/L	44	450	300	30	18	-	-	-	40	350	7	21	2

Применяемые СМП

HPEN



HPEN-WC



Обозначение	Тв. сплав с покрытием								Кермет			Тв. сплав				Стр.	
	NCM325	NCM335	NC5330	PC3500	PC5300	PC3545	PC9530	PC6510	PC219K	PD2000	CN2000	CN20	CN30	H01	G10		ST30A
HPEN 090408FN																	
090408SN																	
090408EN																	
090408-WC																	

E07

Применяемые оправки

Обозначение	Оправка	
DPH 5100R/L	NT*□□ (M/U)-FMA31.75-□□	-
5125R/L	NT*□□ (M/U)-FMA38.1-□□	-
5160R/L	NT*□□ (M/U)-FMA50.8-□□	-
5200R/L	-	APR200
5250R/L	-	APR250
5315R/L	-	APR315
5355R/L	-	APR355
5400R/L	-	APR400
5450R/L	-	APR450

Рекомендуемые режимы резания

Обрабатываемые материалы	Режимы резания		Марка сплава
	V _p , м/мин	S _z , мм/зуб	
К	100 ~ 200	0.05 ~ 0.30	PC6510 H01,G10
	80 ~ 150	0.10 ~ 0.30	

Комплектующие

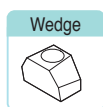

WDPH5R/L

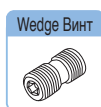

DHA0821F



HW40

Схема сборки

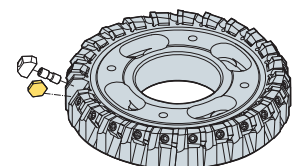

PNH4000/5000



Рис. 1



Рис. 2

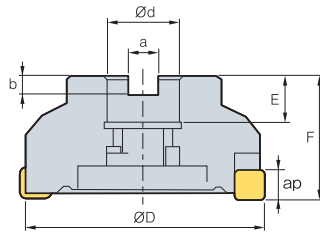

AA
90°
• AR : -5°
• RR : -6°

(мм)

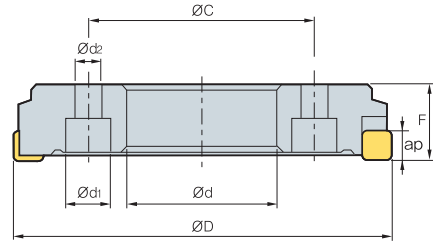
Обозначение		$\varnothing D$	$\varnothing d$	$\varnothing d_1$	$\varnothing d_2$	a	b	E	F	$\varnothing C$	ap		Рис.
PNH	4125R/L	10	125	38.1	-	15.9	10	27	63	-	Max 0.5	3.4	1
	4160R/L	14	160	50.8	-	19.0	11	27	63	-	Max 0.5	5.5	1
	4200R/L	18	200	80	24	14	-	-	40	120	Max 0.5	5.5	2
	4250R/L	24	250	120	30	18	-	-	40	170	Max 0.5	7.7	2
	4315R/L	30	315	180	30	18	-	-	40	230	Max 0.5	10.5	2
	4355R/L	34	355	220	30	18	-	-	40	270	Max 0.5	12.9	2
	4400R/L	38	400	250	30	18	-	-	40	300	Max 0.5	16.1	2
	4450R/L	44	450	300	30	18	-	-	40	350	Max 0.5	19.1	2
PNH	5125R/L	10	125	38.1	-	15.9	10	27	63	-	Max 0.5	3.4	1
	5160R/L	14	160	50.8	-	19.0	11	27	63	-	Max 0.5	5.3	1
	5200R/L	18	200	80	24	14	-	-	40	120	Max 0.5	5.4	2
	5250R/L	24	250	120	30	18	-	-	40	170	Max 0.5	7.6	2
	5315R/L	30	315	180	30	18	-	-	40	230	Max 0.5	10.4	2
	5355R/L	34	355	220	30	18	-	-	40	270	Max 0.5	12.8	2
	5400R/L	38	400	250	30	18	-	-	40	300	Max 0.5	15.9	2
	5450R/L	44	450	300	30	18	-	-	40	350	Max 0.5	18.9	2

Применяемые СМП

SNEF



Обозначение	Тв. сплав с покрытием								Кермет			Тв. сплав				Стр.		
	NCM325	NCM335	NC5330	PC3500	PC3300	PC3545	PC3530	PC6510	PC219K	PD2000	CN2000	CN20	CN30	H01	G10		ST30A	ST20
SNEF 435								●										E17

Применяемые оправки

Обозначение	Оправка	
PNH 125R/L	NT*□□(M/U)-FMA38.1-□□	-
160R/L	NT*□□(M/U)-FMA50.8-□□	-
200R/L	-	APR200
250R/L	-	APR250
315R/L	-	APR315
355R/L	-	APR355
400R/L	-	APR400
450R/L	-	APR450

Рекомендуемые режимы резания

Обрабатываемые материалы	Режимы резания		Марка сплава
	Vp, м/мин	Sz, мм/зуб	
K	100 ~ 200	0.05 ~ 0.30	PC6510 H01,G10
	80 ~ 150	0.10 ~ 0.30	

Комплектующие



4000 Тип	WPNH4N	DHA0821F	HW40
5000 Тип	WPNH5N		

Схема сборки

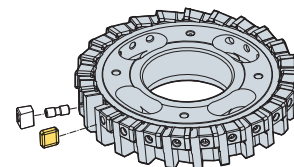

PPH4000



Рис. 1



Рис. 2

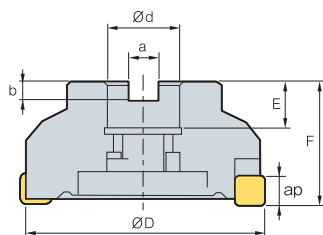

AA
90°
• AR : 5°
• RR : -6°

(мм)

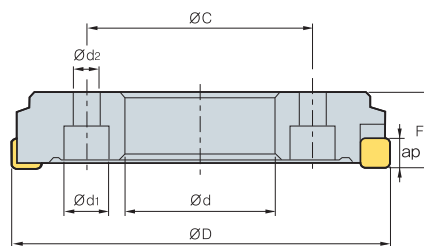
Обозначение		$\varnothing D$	$\varnothing d$	$\varnothing d_1$	$\varnothing d_2$	a	b	E	F	$\varnothing C$	ap		Рис.
PPH 4125R/L		10	125	38.1	-	15.9	10	27	63	-	Max 0.5	3.4	1
4160R/L		14	160	50.8	-	19.0	11	27	63	-	Max 0.5	5.3	1
4200R/L		18	200	80	24	14	-	-	40	120	Max 0.5	5.5	2
4250R/L		24	250	120	24	14	-	-	40	170	Max 0.5	7.7	2
4315R/L		30	315	180	30	18	-	-	40	230	Max 0.5	10.5	2
4355R/L		34	355	220	30	18	-	-	40	270	Max 0.5	13	2
4400R/L		38	400	250	30	18	-	-	40	300	Max 0.5	16	2
4450R/L		44	450	300	30	18	-	-	40	350	Max 0.5	19	2

Применяемые СМП

SPEN-WC

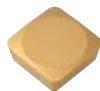

Обозначение	Тв. сплав с покрытием								Кермет			Тв. сплав				Стр.	
	NCM325	NCM335	NC5330	PC3500	PC5300	PC3545	PC9530	PC6510	PC215K	PD2000	CN2000	CN20	CN30	H01	G10		ST30A
SPEN 120416-WC																	E20

Применяемые оправки

Обозначение	Оправка	
PPH 4125R/L	NT*□□(M/U)-FMA38.1-□□	-
4160R/L	NT*□□(M/U)-FMA50.8-□□	-
4200R/L	-	APR200
4250R/L	-	APR250
4315R/L	-	APR315
4355R/L	-	APR355
4400R/L	-	APR400
4450R/L	-	APR450

Рекомендуемые режимы резания

Обрабатываемые материалы	Режимы резания		Марка сплава
	V _p , м/мин	S _z , мм/зуб	
K	100 ~ 200	0.05 ~ 0.30	PC6510 H01,G10
	80 ~ 150	0.10 ~ 0.30	

Комплектующие



WPPH4R/L



DHA0821F



HW40

Схема сборки

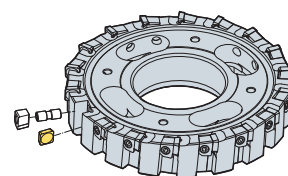

SVM(M)4000

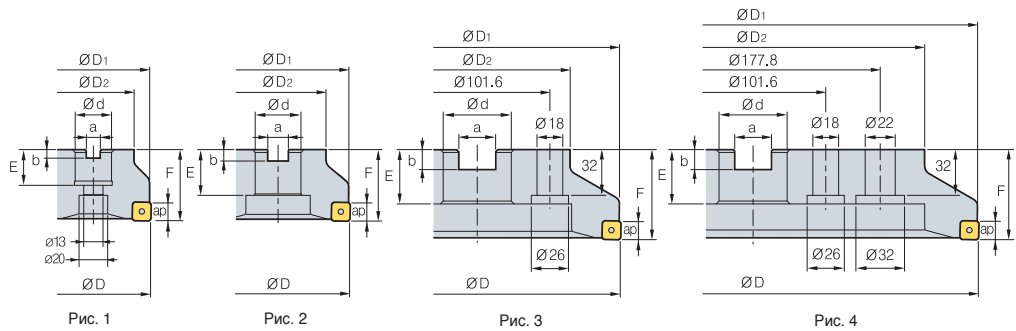

(мм)

Обозначение		ØD	ØD1	ØD2	Ød	a	b	E	F	ap		Рис.	
SVM	4080R/L-Z8	8	80	79	57	25.4	12.4	6	25	50	1.0	1.2	1
	4100R/L-Z12	12	100	99	67	31.75	14.4	8	32	63	1.0	2.3	1
	4125R/L-Z16	16	125	124	87	38.1	16.4	10	38	63	1.0	3.5	2
	4160R/L-Z20	20	160	159	107	50.8	16.4	11	38	63	1.0	5	2
	4200R/L-Z24	24	200	199	130	47.625	25.7	14	38	63	1.0	7.2	3
	4250R/L-Z30	30	250	249	180	47.625	25.7	14	38	63	1.0	12	3
4315R/L-Z36	36	315	314	240	47.625	25.7	14	38	63	1.0	19.5	4	
SVMM	4080R/L-Z8	8	80	79	57	27	12.4	7	22	50	1.0	1.2	1
	4100R/L-Z12	12	100	99	67	32	14.4	8	28	63	1.0	2.3	1
	4125R/L-Z16	16	125	124	87	40	16.4	9	30	63	1.0	3.5	2
	4160R/L-Z20	20	160	159	107	40	16.4	9	30	63	1.0	5	3
	4200R/L-Z24	24	200	199	130	60	25.7	14	38	63	1.0	7.2	3
	4250R/L-Z30	30	250	249	180	60	25.7	14	38	63	1.0	12	3
4315R/L-Z36	36	315	314	240	60	25.7	14	38	63	1.0	19.5	4	

Применяемые СМП

Обозначение	Тв. сплав с покрытием							cBN		Тв. сплав				Стр.			
	NCM325	NCM335	NC5330	PC3500	PC5300	PC3545	PC9530	PC6510	PC215K	PD2000	DBN700	DBN920	H01		G10	ST30A	ST20
SNEU 120420-MF																	E18
1204ANN-MF																	
1204-WMF																	
1204-TBW																	

Комплектующие



WKAJ3 DTA0619 ХТКА0412 TW15-100



SVUM6000



Рис. 1



Рис. 2

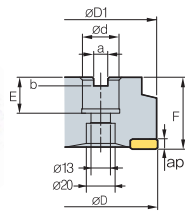

Рис. 3

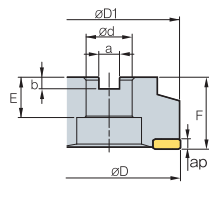

Рис. 4

											(мм)	
Обозначение		$\varnothing D$	$\varnothing D1$	$\varnothing D2$	$\varnothing d$	a	b	E	F	ap		Рис.
SVUM 6080R/L-Z4	4	80	79	57	27	12.4	7	22	50	0.5	1.2	1
6100R/L-Z4	4	100	100	67	32	14.4	8	28	63	0.5	2.3	1
6125R/L-Z4	4	125	125	87	40	16.4	9	30	63	0.5	3.5	2
6160R/L-Z4	4	160	160	107	40	16.4	9	30	63	0.5	5	3
6200R/L-Z6	6	200	200	130	60	25.7	14	38	63	0.5	7.2	3
6250R/L-Z6	6	250	250	180	60	25.7	14	38	63	0.5	12	3
6315R/L-Z8	8	315	315	240	60	25.7	14	38	63	0.5	19.5	4

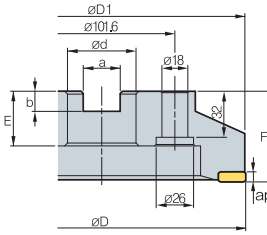
Применяемые СМП

LNCS(R3.0)

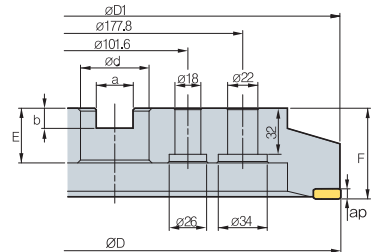
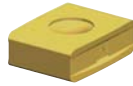

LNCS(C1.5)

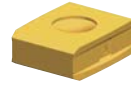

Обозначение	Тв. сплав с покрытием									Кермет			Тв. сплав				Стр.	
	NCM325	NCM335	NC5330	PC3500	PC5300	PC3545	PC9530	PC6510	PC215K	PD2000	CN2000	CN20	CN30	H01	G10	ST30A		ST20
LNCS 1907-R3.0-WC 1907-C1.5-WC																		E09

Комплектующие



FTNA0513



TW20-100

SVUM6000-B



Рис. 1



Рис. 2

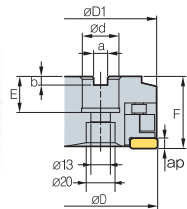

Рис. 3

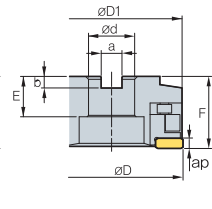

Рис. 4

(мм)

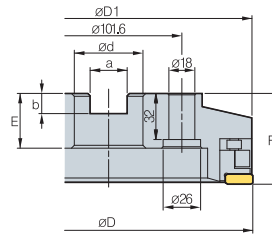
Обозначение		$\varnothing D$	$\varnothing D1$	$\varnothing D2$	$\varnothing d$	a	b	E	F	ap		Рис.
SVUM 6080R/L-Z4-B	4	80	79	57	27	12.4	7	22	50	0.5	1.2	1
6100R/L-Z4-B	4	100	99	67	32	14.4	8	28	63	0.5	2.3	1
6125R/L-Z4-B	4	125	124	87	40	16.4	9	30	63	0.5	3.5	2
6160R/L-Z4-B	4	160	160	107	40	16.4	9	30	63	0.5	5	3
6200R/L-Z6-B	6	200	200	130	60	25.7	14	38	63	0.5	7.2	3
6250R/L-Z6-B	6	250	250	180	60	25.7	14	38	63	0.5	12	3
6315R/L-Z8-B	8	315	315	240	60	25.7	14	38	63	0.5	19.5	4

Применяемые СМП

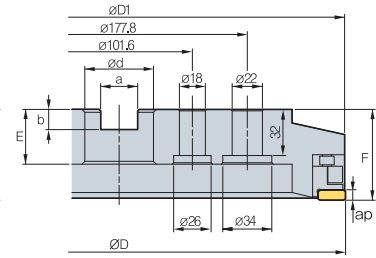
LNCS(R3.0)

LNCS(C1.5)

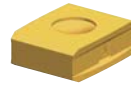
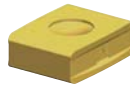

Обозначение	Тв. сплав с покрытием									Кермет			Тв. сплав				Стр.	
	NCM325	NCM335	NC5330	PC3500	PC5300	PC3545	PC9530	PC6510	PC215K	PD2000	CN2000	CN20	CN30	H01	G10	ST30A		ST20
LNCS 1907-R3.0-WC 1907-C1.5-WC																		E09

Комплектующие



LSH4R



WSH4



DHA0724F

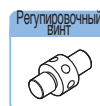

DHA0724F

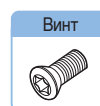

FTNA0512



TW20-100



Дюймовая система измерений

Присоединительные размеры фрез

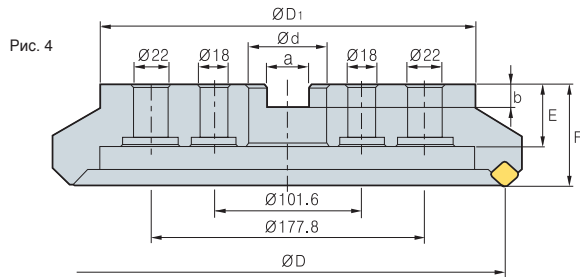
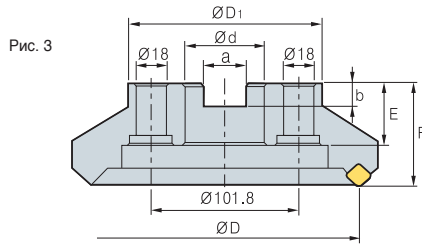
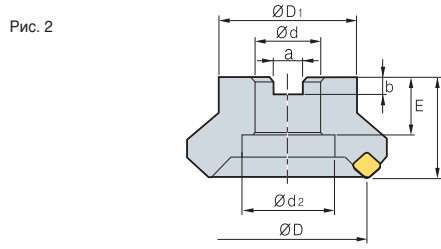
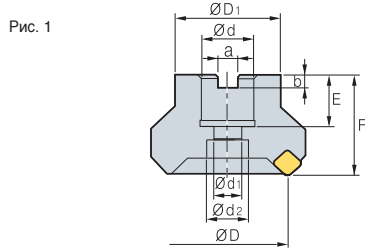

Размеры фрез (дюймовая система измерения)

Размеры, мм										Рис.	Оправки
ØD	Ød	a	b	E	F	ØD1	Ød1	Ød2			
40	16	8.4	5.6	18	40	34	9	14	1	FMC16, SMA16	
50	22	10.4	6.3	20	40	42	11	18	1	FMC22	
63	22	10.4	6.3	20	40	49	11	18	1	FMC22	
80	25.4	9.5	6	25	50	57	14	20	1	FMA25.4	
100	31.75	12.7	8	32	50	67	-	45	2	FMA31.75, SMB31.75	
125	38.1	15.9	10	38	63	87	-	56	2	FMA38.1	
160	50.8	19	11	38	63	107	-	-	2	FMA50.8	
200	47.625	25.4	14	38	63	130	-	-	3	FMA47.625	
250	47.625	25.4	14	38	63	180	-	-	3	FMA47.625	
315	47.625	25.4	14	38	63	240	-	-	4	-	

Крепежный винт (исполнение 1)

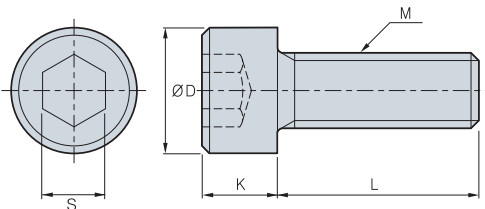

Обозначение	ØD	S	K	L	M	Диаметр фрезы
SB0825	13	6	8	25	M08 x 1.25	Ø40
SB1025	16	8	10	25	M10 x 1.50	Ø50, Ø63
SB1035	16	8	10	35	M10 x 1.50	Ø50, Ø63(HRM)
SB1230	18	10	12	30	M12 x 1.75	Ø80
SB1630	24	14	16	30	M16 x 2.0	Ø100
SB1645	24	14	16	45	M16 x 2.0	Ø80, Ø100(HRM)
SB2040	30	17	20	40	M20 x 2.5	Ø125

Крепежный винт (исполнение 2)

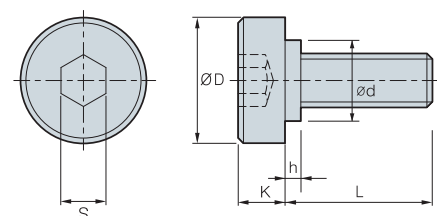

Обозначение	Размеры, дюйм						Диаметр фрезы
	D	L	K	S	h	d	
M8 X 1.25	20	20	7	6	-	-	Ø40
M10 X 1.5	28	24	9	8	-	-	Ø50, Ø63
M12 X 1.75	33	28	10	10	2	23	Ø80
M16 X 2	40	32	10	14	5	23	Ø100
M20 X 2.5	50	40	14	17	5	27	Ø125
M24 X 3	64	46	14	19	9	37	Ø160



Метрическая система измерений

Присоединительные размеры фрез

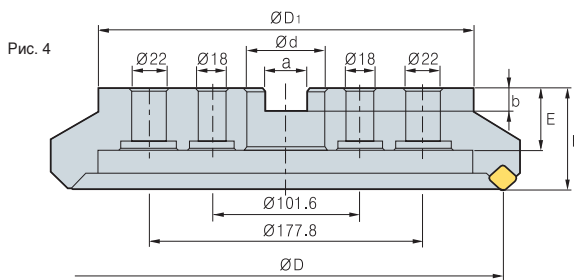
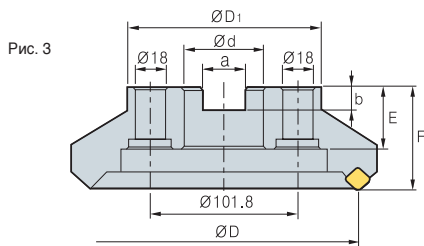
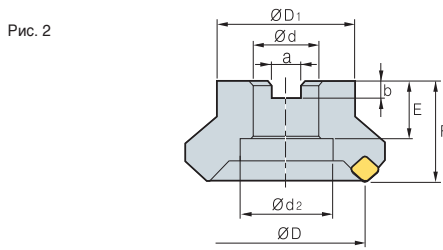
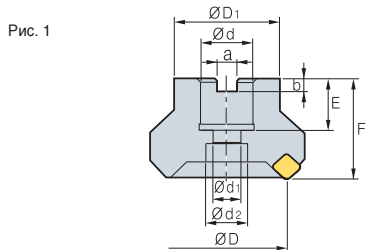

Размеры фрез (метрическая система измерения)

Размеры, мм										Рис.	Оправки
ØD	Ød	a	b	E	F	ØD ₁	Ød ₁	Ød ₂			
40	16	8.4	5.6	18	40	34	9	14	1	FMC16, SMA16	
50	22	10.4	6.3	20	40	42	11	18	1	FMC22	
63	22	10.4	6.3	20	40	49	11	18	1	FMC22	
80	27	12.4	7	22	50	57	14	20	1	FMC27	
100	32	14.4	8	28	50	67	-	45	2	FMC32	
125	40	16.4	9	32	63	87	-	56	2	FMB40	
160	40	16.4	9	32	63	107	-	-	2	FMB40	
200	60	25.7	14	38	63	130	-	-	3	FMB60	
250	60	25.7	14	38	63	180	-	-	3	FMB60	
315	60	25.7	14	38	63	240	-	-	4	-	

Крепежный винт (исполнение 1)

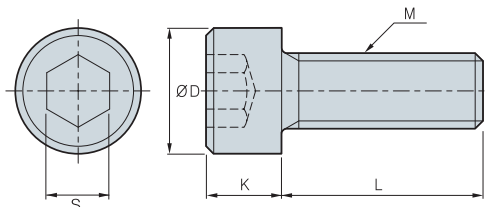

Обозначение	ØD	S	K	L	M	Диаметр фрезы
SB0825	13	6	8	25	M08 × 1.25	Ø40
SB1025	16	8	10	25	M10 × 1.50	Ø50, Ø63
SB1035	16	8	10	35	M10 × 1.50	Ø50, Ø63(HRM)
SB1230	18	10	12	30	M12 × 1.75	Ø80
SB1245	18	10	12	45	M12 × 1.75	Ø80(HRM)
SB1630	24	14	16	30	M16 × 2.0	Ø100
SB1645	24	14	16	45	M16 × 2.0	Ø100(HRM)
SB2040	30	17	20	40	M20 × 2.5	Ø125

Крепежный винт (исполнение 2)

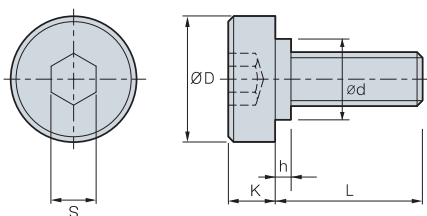

Обозначение	Размеры, мм						Диаметр фрезы
	D	L	K	S	h	d	
M12 X 1.75	33	28	10	10	2	23	Ø80
M16 X 2	40	32	10	14	5	23	Ø100
M20 X 2.5	50	40	14	17	5	27	Ø125, Ø160



Присоединительные размеры торцевых фрез (с отверстиями для подвода СОЖ)

Присоединительные размеры фрез

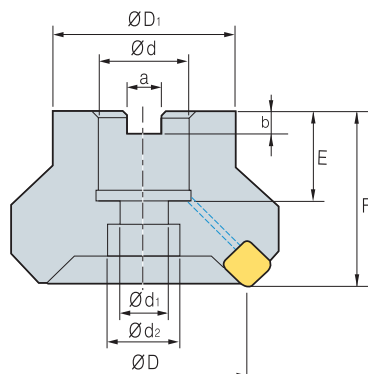

Размеры фрез (дюймовая система измерения)

Размеры, мм									Оправки
ØD	Ød	a	b	E	F	ØD ₁	Ød ₁	Ød ₂	
40	16	8.4	5.6	19	40	34	9	14	FMC16,SMA16
50	22	10.4	6.3	21	40	42	11	18	FMC22
63	22	10.4	6.3	21	40	49	11	18	FMC22
80	25.4	9.5	6	24	50	57	14	20	FMA25.4,FMB25.4
100	31.75	12.7	8	32	63	67	18	26	FMA31.75, SMB31.75
125	38.1	15.9	10	35	63	87	22	32	FMA38.1,FMB38.1,FMC38.1

Метрика Тип

Размеры, мм									Оправки
ØD	Ød	a	b	E	F	ØD ₁	Ød ₁	Ød ₂	
40	16	8.4	5.6	19	40	34	9	14	FMC16,SMA16
50	22	10.4	6.3	21	40	42	11	18	FMC22
63	22	10.4	6.3	21	40	49	11	18	FMC22
80	27	12.4	7.0	23	50	57	14	20	FMC27
100	32	14.4	8.0	25	50	67	18	26	FMC32
125	40	16.4	9.0	29	63	87	22	32	FMB40 / FMC40

Крепежный винт с каналами для подвода СОЖ

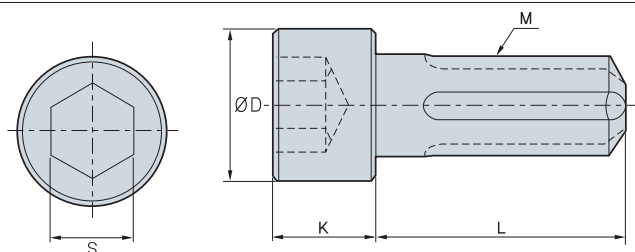

Обозначение	D	S	K	L	M	Диаметр фрезы
CB0825	13	6	8	25	M08x1.25	Ø40
CB1025	16	8	10	25	M10x1.50	Ø50, Ø63
CB1035	16	8	10	35	M10x1.50	Ø50, Ø63(HRM)
CB1230	18	10	12	30	M12x1.75	Ø80
CB1245	18	10	12	45	M12x1.75	Ø80(HRM)
CB1630	24	14	16	30	M16x2.0	Ø100
CB1645	24	14	16	45	M16x2.0	Ø100(HRM)
CB2040	30	17	20	40	M20x2.5	Ø125









Типовые конструкции фрез

Фрезы для нарезания наружных зубьев

Чистовая : M20	Получистовая	Черновая
 <ul style="list-style-type: none"> Диаметр фрезы : $\varnothing 400$ Число зубьев : 20 Наружная зубонарезание : Возможность получения высокой точности профиля зуба. возможность фрезерования пазов и фасок. 	 <ul style="list-style-type: none"> Cutter Dia : $\varnothing 280$ Число зубьев : 48 Чугуны Черновая обработка инвалютного профиля Возможность обработки ножки зуба оптимальным радиусом пластины. 	 <ul style="list-style-type: none"> Cutter Dia : $\varnothing 300$ Число зубьев : 60 Обеспечение высокая производительность благодаря применению высоких подач. Низкие силы резания за счет специальной V-образной геометрии пластины. Раздельное резание.
 <p>M20XZ130-EX</p>	 <p>M20-M22-ROU</p>	 <p>LNE333-02-1 LNE434-02-1 KEL1906-C0.6-MF</p>

Фрезы для нарезания внутренних зубьев

Чистовая : M16	Получистовая	Черновая
 <ul style="list-style-type: none"> Диаметр фрезы : $\varnothing 400$ Число зубьев : 20 Наружная зубонарезание : Возможность получения высокой точности профиля зуба. Возможность фрезерования пазов и фасок. 	 <ul style="list-style-type: none"> Диаметр фрезы : $\varnothing 280$ Число зубьев : 48 фреза разработана для обработки профиля наружной эвольвенты. 	 <ul style="list-style-type: none"> Диаметр фрезы : $\varnothing 560$ Число зубьев : 40 Тип фрез который применим для черновой обработки различных модулей.
 <p>M16XZ130</p>	 <p>M16-M18-ROU LNE433-R60</p>	 <p>KEL1906-C0.6-MF LNE434-02-1</p>

Типовые примеры использования фрез



Станок
Gleason PFAUTER CNC
Hobbing Machine
Мощность 52 kW

• **Режимы резания**
Vp=119,98 м/мин (n=86,8 об/мин)
Sz=0,518 мм/зуб (S мин=150 мм/мин)
t=36 мм, сухое резание

• **Обозначение фрезы**
M16 PT RACK KOR03 ($\varnothing 440 \times W90$)
Низкая скорость, низкие силы резания













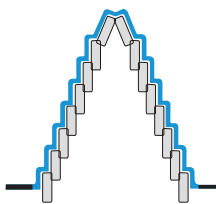

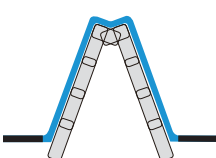

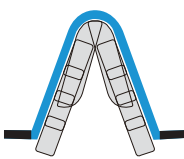
Станок
Gleason PFAUTER CNC
Hobbing Machine
Мощность 52 kW

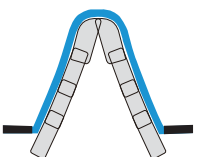
• **Режимы резания**
Vp=150 м/мин (n=119 об/мин)
Sz=0,09 мм/зуб (S мин=81,6 мм/мин)
t=45 мм, сухое резание

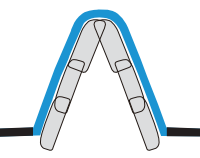
• **Обозначение фрезы**
M24 Semi finishing External тип
M40 ROU (Main), CPE 424 01

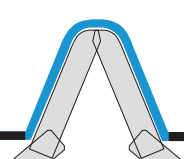

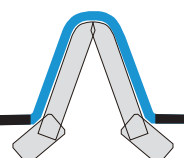
Стандартные типы модульных дисковых сборных фрез

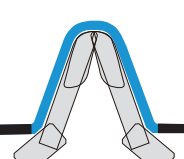
Тип	Эскиз	Профиль нарезаемого зуба	Тип	Характеристики
Черновая			Ступенчатый	<ol style="list-style-type: none"> 1. Обработка зубьев с крупным модулем. 2. Снижение сил резания за счет применения схемы раздельного (ступенчатого) резания.
			V образный профиль	<ol style="list-style-type: none"> 1. Снижение сил резания благодаря V образному профилю рабочей части. 2. Шахматное расположение пластин.
Получистовая			Сниженные силы резания	<ol style="list-style-type: none"> 1. Экономичность применения благодаря использованию СМП с 4 мя режущими кромками на ножках зубьев фрезы. 2. Наличие стружколома на передней поверхности СМП. 3. Снижение сил резания за счет применения схемы раздельного (ступенчатого) резания.
			Наружное нарезание зубьев. Повышенная жесткость корпуса	<ol style="list-style-type: none"> 1. Специальная геометрия пластин, формирующая профиль ножки зуба шестерни. 2. Высокая эффективность получистовой обработки благодаря высокой жесткости конструкции фрезы.
			Внутреннее нарезание зубьев. Повышенная жесткость корпуса	<ol style="list-style-type: none"> 1. Высокая эффективность получистовой обработки. 2. Оптимальное расположение пластин разделяющих полную ширину срезаемого слоя.
Чистовая			Наружное нарезание зубьев	<ol style="list-style-type: none"> 1. Высокая жесткость конструкции фрезы, высокая точность профиля благодаря схеме одинарного резания. 2. Оптимальная геометрия пластин проектируется согласно требованиям заказчика.
			Внутреннее нарезание зубьев.	<ol style="list-style-type: none"> 1. Универсальность применения профильных двухвершинных пластин на правую и левую сторону фрезы 2. Возможность оптимальной установки фасочных пластин благодаря регулируемым кассетам.
			Двухступенчатый тип	<ol style="list-style-type: none"> 1. Высокая точность фрезерования ножек зубьев 2. Экономичность за счет применения четырехгранных СМП



Черновая обработка (ступенчатый тип расположения зубьев)

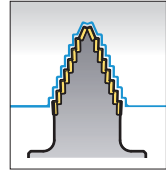
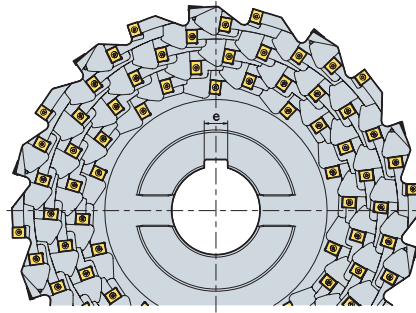
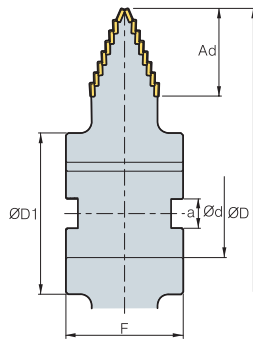

									(мм)
m		ØD	Ad	Ød	ØD1	a	e	F	
30	96	450	90	100	180	25	14	140	
	108	500	90	100	180	25	14	140	
	120	560	90	120	220	40	32	160	
40	112	450	105	100	180	25	14	140	
	126	500	105	100	180	25	14	140	
	140	560	105	120	220	40	32	160	
50	160	560	119	120	220	40	32	160	

Применяемые СМП

Форма	Обозначение	Тв. сплав с покрытием				Тв. сплав		Геометрические размеры					Геометрия		
		NC5330	PC9530	PC3500	PC5300	H01	G10	l	d	t	d _t	c			
 Упрочненная режущая кромка	LNE 434-02-1			○	◎			19.05	14.29	6.35	5.4	0.6			
 Сниженные силы резания	KEL 1906-C0.6-MF 190610-MR			○	◎			19.05	14.29	6.35	5.4	0.6			
				○	◎			19.05	14.29	6.35	5.4	-			

* Возможны изменения геометрических размеров фрезы согласно требованиям заказчика

◎ : Первичный выбор ○ : Вторичный выбор



Черновая обработка (V-образный профиль)

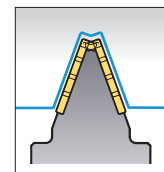
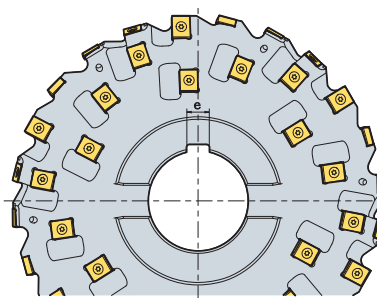
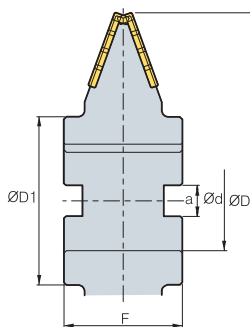

									(мм)
m	Тип		$\varnothing D$	$\varnothing d$	$\varnothing D_1$	a	e	F	
20	rack	48	280	80	135	25	18	95	
22	rack	48	280	80	135	25	18	95	
24	rack	48	320	80	145	25	18	105	
26	rack	60	320	80	145	25	18	105	
28	rack	96	400	100	180	25	24	130	
30	rack	96	400	100	180	25	24	130	
32	rack	96	400	100	180	25	24	130	
34	rack	112	400	100	180	25	24	130	
36	rack	112	450	100	180	25	24	130	
38	rack	112	450	100	180	25	24	130	
40	rack	128	450	100	180	25	24	160	
42	rack	128	450	100	180	25	24	160	
44	rack	128	560	120	220	32	32	160	
46	rack	144	560	120	220	32	32	160	
48	rack	144	560	120	220	32	32	160	
50	rack	144	560	120	220	32	32	160	

Применяемые СМП

(мм)

Форма	Обозначение	Тв. сплав с покрытием						Тв. сплав		Геометрические размеры					Геометрия
		NC5330	PC9530	PC3500	PC5300	NCM325	PC6510	H01	G10	l	d	t	d ₁	c	
	LNE 434-02-1			○	◎					19.05	14.29	6.35	5.4	0.6	
Упрочненная режущая кромка															
	KEL 1906-C0.6-MF 190610-MR			○	◎					19.05	14.29	6.35	5.4	0.6	
Сниженные силы резания				○	◎					19.05	14.29	6.35	5.4	-	
	LNE 333-02-1			○	◎					14.3	12.7	6.35	5.8	0.8	
Упрочненная режущая кромка															
	CNHQ 1005-C0.5									10	10	5.4	-	-	

* Возможны изменения геометрических размеров фрезы согласно требованиям заказчика

◎ : Первичный выбор ○ : Вторичный выбор

Получистовая обработка (Сниженные силы резания)

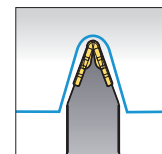
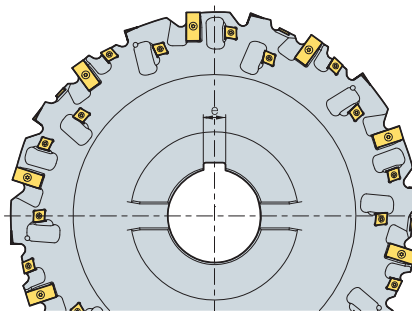
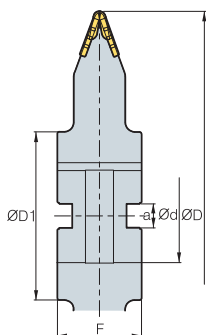

(мм)								
m	Количество зубьев		$\varnothing D$	$\varnothing d$	$\varnothing D_1$	a	e	F
6	30,60,120	18	250	60	100	25	14	70
8	30,60,120	18	250	60	100	25	14	80
10	30,60,120	24	250	60	100	25	14	80
12	30,60,120	24	250	60	100	25	14	90
14	30,60,120	24	280	80	135	25	18	95
16	30,60,120	32	280	80	135	25	18	100
18	30,60,120	32	320	80	145	25	18	105
20	30,60,120	64	400	100	180	25	24	110
22	30,60,120	64	400	100	180	25	24	110
24	30,60,120	64	400	100	180	25	24	120

Применяемые СМП

Форма	Обозначение	Тв. сплав с покрытием				Тв. сплав		Геометрические размеры					Геометрия	
		NC5330	PC9530	PC3500	PC5300	H01	G10	l	d	t	d ₁	R		
	M6-2ST			○	◎			19.05	11.6	3.8	4.4	2.25		
	M8-2ST			○	◎			19.05	11.6	4	4.4	3		
	M10-2ST			○	◎			19.05	11.6	4.76	4.4	3.75		
	M12-2ST			○	◎			19.05	14.3	6.35	5.5	4.5		
	M14-2ST			○	◎			25.4	14.3	6.35	5.5	5.25		
	M16-2ST			○	◎			31.8	14.3	7.14	5.5	6		
	M18-2ST			○	◎			31.8	14.3	7.14	5.5	6.75		
	M20-2ST			○	◎			31.8	14.3	9.52	5.5	7.5		
	M22-2ST			○	◎			31.8	14.3	9.52	5.5	8.25		
M24-2ST			○	◎			31.8	14.3	9.52	5.5	9			
	KEC 120606-MX			○	◎			12	12.7	6.35	4.5	-		
	150708-MX			○	◎			15.15	15	7.6	5.8	-		

* Возможны изменения геометрических размеров фрезы согласно требованиям заказчика

◎ : Первичный выбор ○ : Вторичный выбор

Получистовая обработка (Наружное нарезание зубьев, повышенная жесткость корпуса)

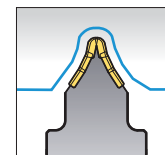
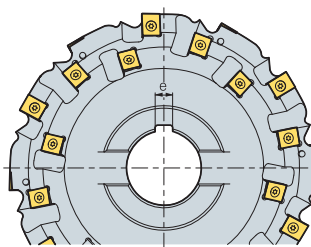
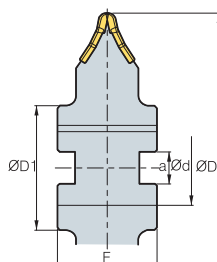

									(мм)
m	Количество зубьев		$\varnothing D$	$\varnothing d$	$\varnothing D_1$	a	e	F	
12	30,60,120	24	250	60	100	25	14	70	
14	30,60,120	36	250	60	100	25	14	80	
16	30,60,120	36	250	60	100	25	14	80	
18	30,60,120	36	250	60	100	25	14	90	
20	30,60,120	48	280	80	135	25	18	95	
22	30,60,120	48	280	80	135	25	18	100	
24	30,60,120	48	320	80	145	25	18	105	
26	30,60,120	72	400	100	180	25	24	110	
28	30,60,120	72	400	100	180	25	24	110	
30	30,60,120	72	400	100	180	25	24	120	
32	30,60,120	84	400	100	180	25	24	130	
34	30,60,120	84	400	100	180	25	24	130	

Применяемые СМП

Форма	Обозначение	Тв. сплав с покрытием				Тв. сплав		Геометрические размеры					Геометрия	
		NC5330	PC9530	PC3500	PC5300	H01	G10	l	d	t	d ₁	R		c
	M8-ROU			○	◎			15.875	11	4.76	4.6	4.6	-	
	M12-M14-ROU			○	◎			19.05	14.29	6.35	5.4	5.4	-	
	M16-M18-ROU			○	◎			19.05	14.29	7	5.4	5.4	-	
	M20-M22-ROU			○	◎			19.05	14.29	7.94	5.4	5.4	-	
	M40-ROU			○	◎			25.4	14.29	9.52	5.4	5.4	-	
	LNE434-02-1			○	◎			19.05	14.29	6.35	5.4	-	0.6	
	KEL 1906-CO.6-MF			○	◎			19.05	14.29	6.35	5.4	-	0.6	
	190610-MR			○	◎			19.05	14.29	6.35	5.4	-	-	

* Возможны изменения геометрических размеров фрезы согласно требованиям заказчика

◎ : Первичный выбор ○ : Вторичный выбор

Чистовая обработка (Одинарное резание, наружное нарезание зубьев)

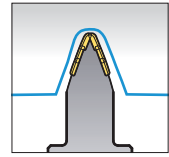
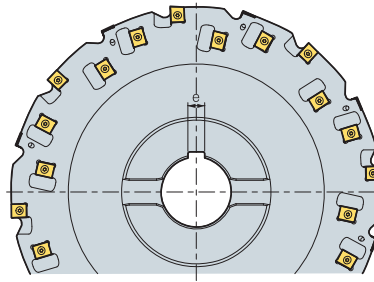
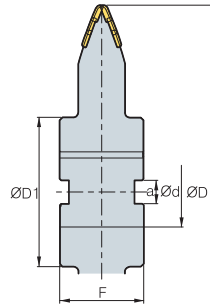

(мм)								
m	Количество зубьев		$\varnothing D$	$\varnothing d$	$\varnothing D_1$	a	e	F
12	30,60,120	24	250	60	100	25	14	70
14	30,60,120	36	250	60	100	25	14	80
16	30,60,120	36	250	60	100	25	14	80
18	30,60,120	36	250	60	100	25	14	90
20	30,60,120	48	280	80	135	25	18	95
22	30,60,120	48	280	80	135	25	18	100
24	30,60,120	48	320	80	145	25	18	105
26	30,60,120	72	400	100	180	25	24	110
28	30,60,120	72	400	100	180	25	24	110
30	30,60,120	72	400	100	180	25	24	120
32	30,60,120	84	400	100	180	25	24	130
34	30,60,120	84	400	100	180	25	24	130

Применяемые СМП

Форма	Обозначение	Тв. сплав с покрытием				Тв. сплав		Геометрические размеры					Геометрия
		NC5330	PC9530	PC3500	PC5300	H01	G10	l	d	t	d ₁	R	
	M8-ROU			○	◎			15.875	11	4.76	4.6	2	
	M12-M14-ROU			○	◎			19.05	14.29	6.35	5.4	3	
	M16-M18-ROU			○	◎			19.05	14.29	7	5.4	5	
	M20-M22-ROU			○	◎			19.05	14.29	7.94	5.4	7	
	M40-ROU			○	◎			25.4	14.29	9.52	5.4	10	
	LNE433-R80			○	◎			19.05	14.29	5.56	5.4	2.5	

* Возможны изменения геометрических размеров фрезы согласно требованиям заказчика

◎ : Первичный выбор ○ : Вторичный выбор

Чистовая обработка (Одинарное резание, наружное нарезание зубьев)

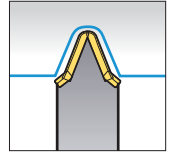
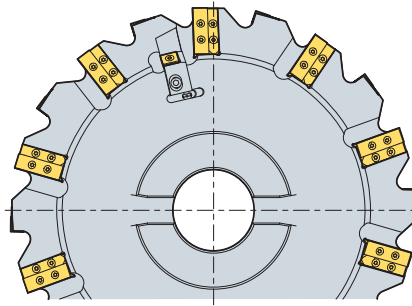
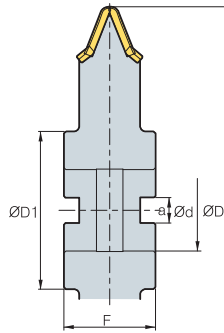

(мм)

m		$\varnothing D$	$\varnothing d$	$\varnothing D_1$	a	F
6	20	400	80	155	25	90
8	20	400	80	155	25	90
10	20	400	80	155	25	90
12	20	400	80	155	25	90
14	20	400	80	155	25	90
16	20	400	80	155	25	90
18	20	400	80	155	25	90
20	20	400	80	155	25	90
22	20	400	80	155	25	90
24	20	400	80	155	25	90

Применяемые СМП

(мм)

Форма	Обозначение	Тв. сплав с покрытием				Тв. сплав		Геометрические размеры					Геометрия
		NC5330	PC9530	PC3500	PC5300	H01	G10	l	d	t	d ₁	R	
	M6			○	◎			19	14.3	5	5.5	2.25	
	M8			○	◎			27	14.3	5.4	5.5	3	
	M10			○	◎			29	14.3	6.35	5.5	3.75	
	M12			○	◎			33	14.3	6.35	5.5	4.5	
	M14			○	◎			39	14.3	6.35	5.5	5.25	
	M16			○	◎			43	14.3	7.94	5.5	6	
	M18			○	◎			50	14.3	7.94	5.5	6.75	
	M20			○	◎			54	14.3	9.53	5.5	7.5	
	M22			○	◎			57	14.3	9.53	5.5	8.25	
	M24			○	◎			64	14.3	9.53	5.5	9	
	SNEQ1507-C0.8			○	◎			15.875	15.875	7.94	-	-	

* Возможны изменения геометрических размеров фрезы согласно требованиям заказчика

◎ : Первичный выбор ○ : Вторичный выбор

Чистовая обработка (Внутреннее нарезание зубьев)

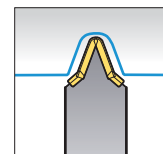
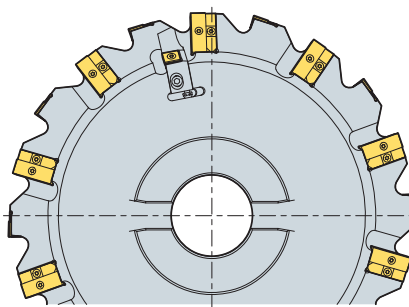
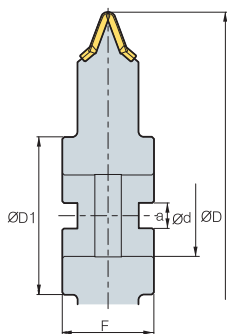

								(мм)
m		$\varnothing D$	$\varnothing d$	$\varnothing D_1$	a	F		
6	20	400	80	155	25	90		
8	20	400	80	155	25	90		
10	20	400	80	155	25	90		
12	20	400	80	155	25	90		
14	20	400	80	155	25	90		
16	20	400	80	155	25	90		
18	20	400	80	155	25	90		
20	20	400	80	155	25	90		
22	20	400	80	155	25	90		
24	20	400	80	155	25	90		

Применяемые СМП

Форма	Обозначение	Тв. сплав с покрытием				Тв. сплав		Геометрические размеры					Геометрия
		NC5330	PC9530	PC3500	PC5300	H01	G10	l	d	t	d ₁	R	
	M6			○	◎			19	14.3	5	5.5	2.25	
	M8			○	◎			27	14.3	5.4	5.5	3	
	M10			○	◎			29	14.3	6.35	5.5	3.75	
	M12			○	◎			33	14.3	6.35	5.5	4.5	
	M14			○	◎			39	14.3	6.35	5.5	5.25	
	M16			○	◎			43	14.3	7.94	5.5	6	
	M18			○	◎			50	14.3	7.94	5.5	6.75	
	M20			○	◎			54	14.3	9.53	5.5	7.5	
	M22			○	◎			57	14.3	9.53	5.5	8.25	
	M24			○	◎			64	14.3	9.53	5.5	9	
	SNEQ1507-C0.8			○	◎			15.875	15.875	7.94	-	-	

* Возможны изменения геометрических размеров фрезы согласно требованиям заказчика

◎ : Первичный выбор ○ : Вторичный выбор

Чистовая обработка (2 Шаг типа, внутренний / наружный передач)

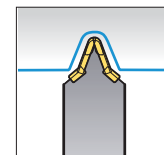
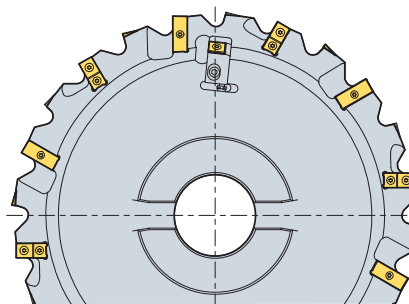
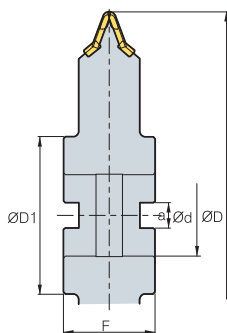

								(мм)
m		$\varnothing D$	$\varnothing d$	$\varnothing D_1$	a	F		
6	24	400	80	155	25	90		
8	24	400	80	155	25	90		
10	24	400	80	155	25	90		
12	24	400	80	155	25	90		
14	24	400	80	155	25	90		
16	24	400	80	155	25	90		
18	24	400	80	155	25	90		
20	24	400	80	155	25	90		
22	24	400	80	155	25	90		
24	24	400	80	155	25	90		

Применяемые СМП

(мм)

Форма	Обозначение	Тв. сплав с покрытием				Тв. сплав		Геометрические размеры					Геометрия
		NC5330	PC9630	PC3500	PC5300	H01	G10	l	d	t	d ₁	R	
	M6		○		◎			19	14.3	5	5.5	2.25	
	M8		○		◎			27	14.3	5.4	5.5	3	
	M10		○		◎			29	14.3	6.35	5.5	3.75	
	M12		○		◎			33	14.3	6.35	5.5	4.5	
	M14		○		◎			39	14.3	6.35	5.5	5.25	
	M16		○		◎			43	14.3	7.94	5.5	6	
	M18		○		◎			50	14.3	7.94	5.5	6.75	
	M20		○		◎			54	14.3	9.53	5.5	7.5	
	M22		○		◎			57	14.3	9.53	5.5	8.25	
M24		○		◎			64	14.3	9.53	5.5	9		
	SNEQ1507-C0.8		○		◎			15.875	15.875	7.94	-	-	
	M6-2ST							19.05	11.6	3.8	4.4	2.25	
	M8-2ST							19.05	11.6	4	4.4	3	
	M10-2ST							19.05	11.6	4.76	4.4	3.75	
	M12-2ST							19.05	14.3	6.35	5.5	4.5	
	M14-2ST							25.4	14.3	6.35	5.5	5.25	
	M16-2ST							31.8	14.3	7.14	5.5	6	
	M18-2ST							31.8	14.3	7.14	5.5	6.75	
	M20-2ST							31.8	14.3	9.52	5.5	7.5	
	M22-2ST							31.8	14.3	9.52	5.5	8.25	
M24-2ST							31.8	14.3	9.52	5.5	9		

* Возможны изменения геометрических размеров фрезы согласно требованиям заказчика

◎ : Первичный выбор ○ : Вторичный выбор

Характеристики фрезы

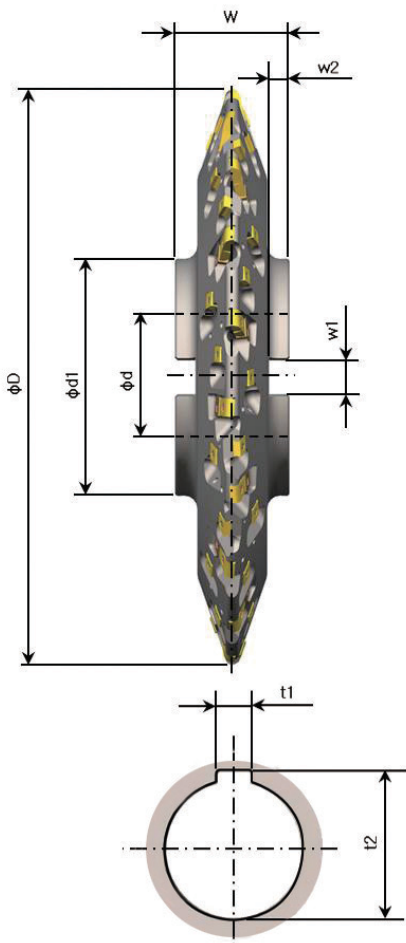

Вид обработки, тип расположения зубьев и особенности фрез

- | | | |
|---|---|--|
| <input type="checkbox"/> Черновая | <input type="checkbox"/> Полуцистовая | <input type="checkbox"/> Чистовая |
| <input type="checkbox"/> Ступенчатый | <input type="checkbox"/> Сниженные силы резания | <input type="checkbox"/> Одинарное резание |
| <input type="checkbox"/> V образный профиль | <input type="checkbox"/> Повышенная жесткость корпуса | <input type="checkbox"/> Групповое резание |

• Величина припуска на сторону, мм

• Наружный диаметр, мм

• Диаметр отверстия, мм

• Диаметр фланца, мм

• Ширина фрезы, мм

• Ширина шпоночного паза, мм

• Ширина шпоночного паза, мм

• Высота шпоночного паза, мм

Характеристики эвольвентного профиля обрабатываемых зубьев

- | | | |
|--|--|--------------------------------|
| <input type="checkbox"/> Наружные зубья шестерни | <input type="checkbox"/> Внутренние зубья шестерни | <input type="checkbox"/> Рейка |
|--|--|--------------------------------|

• Модуль, m , мм

Диаметр окружности впадин d_1 , мм

• Число зубьев Z , мм

Радиус переходного участка ножки и впадины r_p , мм

• Угол давления в полюсе зацепления (угол зацепления) α (°), мм

Длина общей нормали W_k , мм

• Угол наклона зубьев β (°), мм

Количество измеряемых зубьев K

• Коэффициент высоты зуба x

Диаметр, измеренный по роликам (метод проволоочек) M_a , мм

• Диаметр окружности выступов d_a , мм

Диаметр роликов D_m , мм

Класс точности (DIN, JIS)



Сменные НОВ *Новш*

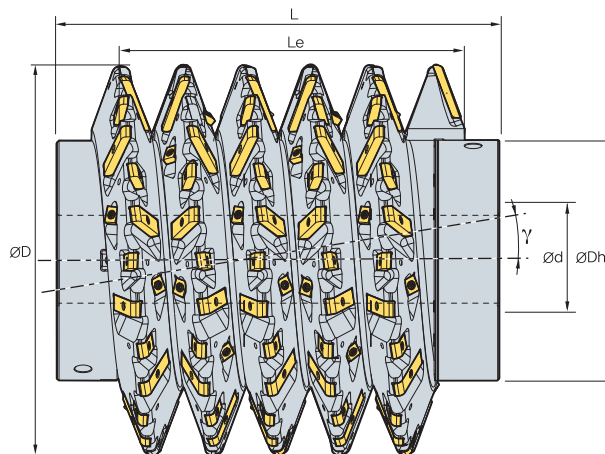

Модуль зубчатой передачи	øD	øDh	ød	Число сегментов (шаг)	Le	Количество СМП на сегменте	Общее количество СМП	γ (Угол подъема)	(мм)
6	180	125	40	6	(113)	15	90	2.084	
	210	125	50	6	(113)	17	102	1.763	
	240	160	60	6	(113)	19	114	1.528	
7	180	125	40	6	(132)	15	90	2.469	
	210	125	50	6	(132)	17	102	2.084	
	240	160	60	6	(132)	19	114	1.803	
8	210	125	50	6	(151)	17	102	2.413	
	240	160	60	6	(151)	19	114	2.084	
	270	180	80	6	(151)	21	126	1.834	
9	210	125	50	6	(169)	17	102	2.751	
	240	160	60	6	(169)	19	114	2.372	
	270	180	80	6	(169)	21	126	2.084	
10	210	125	50	6	(189)	17	102	3.099	
	240	160	60	6	(189)	19	114	2.666	
	270	180	80	6	(189)	21	126	2.339	
12	240	140	60	6	(226)	18	108	3.276	
	270	180	80	6	(226)	22	132	2.866	
	350	215	80	6	(226)	26	156	2.149	
14	270	180	80	6	(264)	22	132	3.415	
	350	215	80	6	(264)	26	156	2.547	
16	270	160	80	6	(302)	22	132	3.989	
	350	215	80	6	(302)	26	156	2.959	
18	270	145	80	5	(283)	22	110	4.589	
	350	215	80	5	(283)	26	130	3.383	
20	350	215	80	5	(314)	26	130	3.823	
	450	265	100	5	(314)	34	170	2.866	



Сменные НОВ

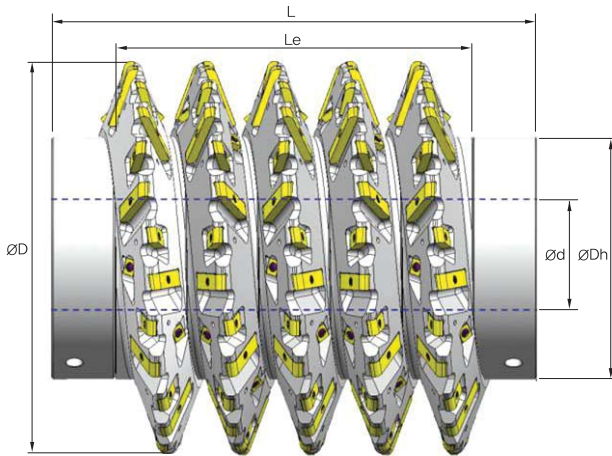

Инструмент SPEC.

- Наружный диаметр ØD (мм) : _____
- Посадочное отверстие Ød (мм) : _____
- Диаметр ступицы ØDh (мм) : _____
- Общая длина L (мм) : _____
- Длина резания L_e (мм) : _____
- Направление спирали правостор./левостор.: _____
- Класс точности по DIN 3968 : _____

Профиль червячной фрезы [Модуль $m_6 \sim$]

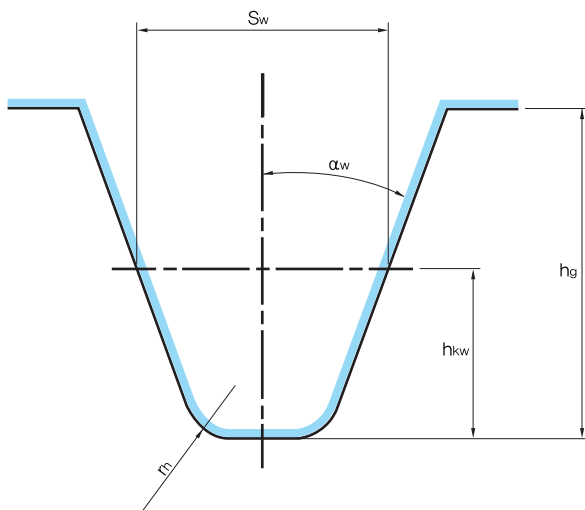

- Модуль M (мм) : _____
- Высота головки h_{kw} (мм) : _____
- Толщина зуба S_w (мм) : _____
- Глубина зуба h_g (мм) : _____

Профиль черновой червячной фрезы [Модуль $m_8 \sim$]

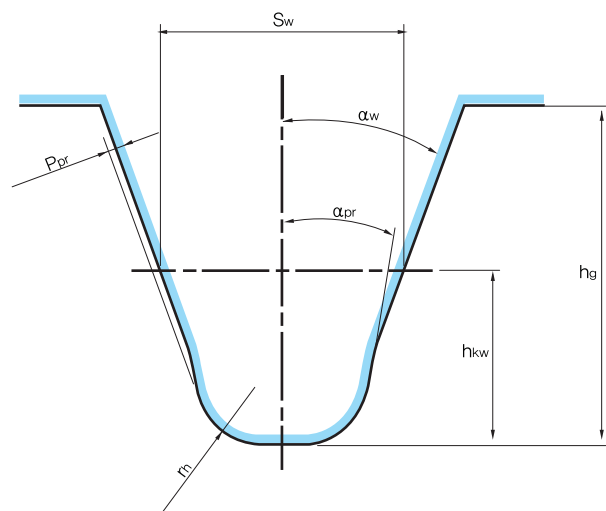

- Угол зацепления α_w (мм) : _____
- Величина выступа P_{pr} (мм) : _____
- Угол выступа α_{pr} (мм) : _____
- Угол выступа α_{pr} r_h (мм) : _____

