





D VHM Hochleistungsfräser

E Solid carbide high performance end mills

I Frese MDI ad alto rendimento



Speedcut 4.0

D Übersicht
VHM-Fräser

E Overview
Solid carbide milling cutters

I Sommario
Frese in metallo duro integrale

D Die Schnittwerte für alle Werkzeuge entnehmen Sie bitte unserem separaten Zerspanungshandbuch.

E You will find the cutting conditions for all tools in our separate cutting manual.

I Per i parametri di lavorazione per tutti gli utensili richiedete il nostro manuale tecnico.

	Speedcut		Speedcut 4.0		Speedcut	
						
	Uni	Uni	Uni	Uni	Uni	Uni
Norm / Standard	DIN 6527K	DIN 6527L	DIN 6527K			
Typ / Type / Tipo	N	N	N	N	N	N
Länge / Length / Lunghezza	kurz-freigestellt	lang-freigestellt	kurz / short	kurz / short	kurz / short	kurz / short
Schneidenanzahl / No. of flutes / Nr. denti	3	3	4	4	4	4
Kopfform / Head type / Tipo di testa						
Drallwinkel / Spiral angle / Angolo elica	34-36°	34-36°	35-38°	35-38°	35-38°	35-38°
Schaftform / Shank type / Forma codolo	DIN 6535-HA	DIN 6535-HA	DIN 6535-HA	DIN 6535-HB	DIN 6535-HA	DIN 6535-HB
Kühlkanäle / Coolant supply / Fori lubrificazione						
Beschichtung / Coating / Rivestimento	ALUNIT-S*	ALUNIT-S*	TWINOUR	TWINOUR	ALUNIT-S*	ALUNIT-S*
Ø mm	2-10	3-10	3-20	3-20	3-20	3-20
Code / Codice	7367	7377	8207	8707	7207	7707
Seite / Page / Pagina	094	095	096	096	097	097
Geeignet für / Suitable for / Adatte per						
 Stähle < 400 N/mm² Steels < 400 N/mm ² Acciai < 400 N/mm ²						
 Stähle < 850 N/mm² Steels < 850 N/mm ² Acciai < 850 N/mm ²						
 Stähle < 1.100 N/mm² Steels < 1.100 N/mm ² Acciai < 1.100 N/mm ²						
 Stähle < 1.300 N/mm² Steels < 1.300 N/mm ² Acciai < 1.300 N/mm ²						
 Stähle > 45 HRC Steels > 45 HRC Acciai > 45 HRC						
 Rostfreie Stähle < 850 N/mm² Stainless steels < 850 N/mm ² Acciai inossidabili < 850 N/mm ²						
 Rostfreie Stähle > 850 N/mm² Stainless steels > 850 N/mm ² Acciai inossidabili > 850 N/mm ²						
 Grauguss, Temperguss Cast iron, malleable cast iron Ghisa grigia, ghisa malleabile						
 Titan- und Titanlegierung Titanium and titanium alloys Titanio e leghe di Titanio						
 Kupfer, Messing Copper, brass Rame, ottone						
 Aluminium Aluminium Alluminio						
 Kunststoffe Plastics Materie plastiche						

D **Übersicht**
VHM-Fräser

E **Overview**
Solid carbide milling cutters

I **Sommario**
Frese in metallo duro integrale

Speedcut		Speedcut 4.0				Speedcut		Speedcut 4.0	
NEW	NEW	NEW	NEW	NEW	NEW			NEW	NEW
Uni	Uni	Uni	Uni	Uni	Uni	Uni	Uni	Uni	Uni
DIN 6527K		DIN 6527L							
N	N	N	N	N	N	N	N	N	N
kurz-freigestellt	kurz-freigestellt	lang / long	lang / long	lang / long	lang / long	lang / long	lang / long	lang-freigestellt	lang-freigestellt
4	4	4	4	3-4	4	3-4	4	4	4
35-38°	35-38°	35-38°	35-38°	35-38°	35-38°	35-38°	35-38°	35-38°	35-38°
DIN 6535-HA	DIN 6535-HB	DIN 6535-HA	DIN 6535-HB	DIN 6535-HA	DIN 6535-HB	DIN 6535-HA	DIN 6535-HB	DIN 6535-HA	DIN 6535-HB
		ja / yes / si	ja / yes / si					ja / yes / si	ja / yes / si
ALUNIT-S®	ALUNIT-S®	TWINDUR	TWINDUR	TWINDUR	TWINDUR	ALUNIT-S®	ALUNIT-S®	TWINDUR	TWINDUR
3-20	3-20	6-20	6-20	2-20	3-20	2-20	3-20	6-20	6-20
7387	7487	8507	8517	8217	8717	7217	7717	8527	8537
098	098	099	099	100	100	101	101	102	102



D Übersicht
VHM-Fräser

E Overview
Solid carbide milling cutters

I Sommario
Frese in metallo duro integrale

D Die Schnittwerte für alle Werkzeuge entnehmen Sie bitte unserem separaten Zerspanungshandbuch.
E You will find the cutting conditions for all tools in our separate cutting manual.
I Per i parametri di lavorazione per tutti gli utensili richiedete il nostro manuale tecnico.

















































Norm / Standard	DIN 6527L				WN	
Typ / Type / Tipo	N	N	N	N	N	N
Länge / Length / Lunghezza	lang-freigestellt	lang-freigestellt	lang-freigestellt	lang-freigestellt	XL-freigestellt	XL-freigestellt
Schneidenanzahl / No. of flutes / Nr. denti	4	4	4	4	4	4
Kopfform / Head type / Tipo di testa						
Drallwinkel / Spiral angle / Angolo elica	35-38°	35-38°	35-38°	35-38°	35-38°	35-38°
Schaftform / Shank type / Forma codolo	DIN 6535-HA	DIN 6535-HB	DIN 6535-HA	DIN 6535-HB	DIN 6535-HA	DIN 6535-HB
Kühlkanäle / Coolant supply / Fori lubrificazione						
Beschichtung / Coating / Rivestimento	TWINDUR	TWINDUR	ALUNIT-S®	ALUNIT-S®	TWINDUR	TWINDUR
Ø mm	3-20	3-20	3-25	3-25	5-20	5-20
Code / Codice	8317	8417	7317	7417	8237	8737
Seite / Page / Pagina	103	103	104	104	105	105

Geeignet für / Suitable for / Adatte per						
Stähle < 400 N/mm² Steels < 400 N/mm² Acciai < 400 N/mm²						
Stähle < 850 N/mm² Steels < 850 N/mm² Acciai < 850 N/mm²						
Stähle < 1.100 N/mm² Steels < 1.100 N/mm² Acciai < 1.100 N/mm²						
Stähle < 1.300 N/mm² Steels < 1.300 N/mm² Acciai < 1.300 N/mm²						
Stähle > 45 HRC Steels > 45 HRC Acciai > 45 HRC						
Rostfreie Stähle < 850 N/mm² Stainless steels < 850 N/mm² Acciai inossidabili < 850 N/mm²						
Rostfreie Stähle > 850 N/mm² Stainless steels > 850 N/mm² Acciai inossidabili > 850 N/mm²						
Grauguss, Temperguss Cast iron, malleable cast iron Ghisa grigia, ghisa malleabile						
Titan- und Titanlegierung Titanium and titanium alloys Titanio e leghe di Titanio						
Kupfer, Messing Copper, brass Rame, ottone						
Aluminium Aluminium Alluminio						
Kunststoffe Plastics Materie plastiche						

D **Übersicht**
VHM-Fräser

E **Overview**
Solid carbide milling cutters

I **Sommario**
Frese in metallo duro integrale

Speedcut				Speedcut 4.0	Speedcut			
								
Uni	Uni	Uni	Uni	Uni	Uni	Uni	Uni	
WN		DIN 6527L	WN	DIN 6527L		DIN 6527L	WN	
N	N	N	N	N	N	N	N	
XL-freigestellt	XL-freigestellt	lang / long	XL	lang-freigestellt	lang-freigestellt	lang-freigestellt	XXL-freigestellt	
4	4	6-8	6-8	4	3-4	4	4	
								
35-38°	35-38°	45°	45°	35-38°	35-38°	35-38°	35-38°	
DIN 6535-HA	DIN 6535-HB	DIN 6535-HA	DIN 6535-HA	DIN 6535-HA	DIN 6535-HA	DIN 6535-HA	DIN 6535-HA	
ALUNIT-S*	ALUNIT-S*	ALUNIT-S*	ALUNIT-S*	TWINDUR	ALUNIT-S*	ALUNIT-S*	ALUNIT-S*	
5-20	5-20	4-20	4-20	6-12	2-20	4-20	3-16	
7237	7737	7327	7337	8547	6447	7357	7857	
106	106	107	108	109	110	112	113	
								
								
								
								
								
								
								
								
								
								
								
								



D Übersicht
VHM-Fräser

E Overview
Solid carbide milling cutters

I Sommario
Frese in metallo duro integrale

D Die Schnittwerte für alle Werkzeuge entnehmen Sie bitte unserem separaten Zerspanungshandbuch.

E You will find the cutting conditions for all tools in our separate cutting manual.

I Per i parametri di lavorazione per tutti gli utensili richiedete il nostro manuale tecnico.

	Speedcut 4.0		Speedcut		Speedcut 4.0	
	Inox	Inox	Inox	Inox	Inox	Inox
Norm / Standard	DIN 6527K				DIN 6527L	
Typ / Type / Tipo	N	N	N	N	N	N
Länge / Length / Lunghezza	kurz-freigestellt	kurz-freigestellt	kurz-freigestellt	kurz-freigestellt	lang / long	lang / long
Schneidenanzahl / No. of flutes / Nr. denti	4	4	4	4	4	4
Kopfform / Head type / Tipo di testa						
Drallwinkel / Spiral angle / Angolo elica	39-42°	39-42°	39-42°	39-42°	39-42°	39-42°
Schaftform / Shank type / Forma codolo	DIN 6535-HA	DIN 6535-HB	DIN 6535-HA	DIN 6535-HB	DIN 6535-HA	DIN 6535-HB
Kühlkanäle / Coolant supply / Fori lubrificazione					ja / yes / si	ja / yes / si
Beschichtung / Coating / Rivestimento	ULTRADUR	ULTRADUR	ALUNIT-S®	ALUNIT-S®	ULTRADUR	ULTRADUR
Ø mm	3-16	3-16	3-16	3-16	6-20	6-20
Code / Codice	8397	8497	7397	7497	8557	8567
Seite / Page / Pagina	114	114	115	115	116	116

































































































































































Geeignet für / Suitable for / Adatte per	Speedcut 4.0 (N)	Speedcut 4.0 (N)	Speedcut (N)	Speedcut (N)	Speedcut 4.0 (N)	Speedcut 4.0 (N)
Stähle < 400 N/mm ² Steels < 400 N/mm ² Acciai < 400 N/mm ²						
Stähle < 850 N/mm ² Steels < 850 N/mm ² Acciai < 850 N/mm ²						
Stähle < 1.100 N/mm ² Steels < 1.100 N/mm ² Acciai < 1.100 N/mm ²						
Stähle < 1.300 N/mm ² Steels < 1.300 N/mm ² Acciai < 1.300 N/mm ²						
Stähle > 45 HRC Steels > 45 HRC Acciai > 45 HRC						
Rostfreie Stähle < 850 N/mm ² Stainless steels < 850 N/mm ² Acciai inossidabili < 850 N/mm ²						
Rostfreie Stähle > 850 N/mm ² Stainless steels > 850 N/mm ² Acciai inossidabili > 850 N/mm ²						
Grauguss, Temperguss Cast iron, malleable cast iron Ghisa grigia, ghisa malleabile						
Titan- und Titanlegierung Titanium and titanium alloys Titanio e leghe di Titanio						
Kupfer, Messing Copper, brass Rame, ottone						
Aluminium Aluminium Alluminio						
Kunststoffe Plastics Materie plastiche	⁽¹⁾	⁽¹⁾	⁽¹⁾	⁽¹⁾	⁽¹⁾	⁽¹⁾

⁽¹⁾ GFK: glasfaser-verstärkte Kunststoffe | GRP: glass-fibre reinforced plastics | FRP: plastica rinforzata con fibra di vetro

D Übersicht
VHM-Fräser

E Overview
Solid carbide milling cutters

I Sommario
Fresa in metallo duro integrale

Speedcut 4.0		Speedcut		Speedcut 4.0				Speedcut	
									
Inox	Inox	Inox	Inox	Inox	Inox	Inox	Inox	Inox	Inox
DIN 6527L									
N	N	N	N	N	N	N	N	N	N
lang / long	lang / long	lang / long	lang / long	lang-freigestellt	lang-freigestellt	lang-freigestellt	lang-freigestellt	lang-freigestellt	lang-freigestellt
3-4	4	3-4	4	4	4	4	4	4	4
									
39-42°	39-42°	39-42°	39-42°	39-42°	39-42°	39-42°	39-42°	39-42°	39-42°
DIN 6535-HA	DIN 6535-HB	DIN 6535-HA	DIN 6535-HB	DIN 6535-HA	DIN 6535-HB	DIN 6535-HA	DIN 6535-HB	DIN 6535-HA	DIN 6535-HB
				ja / yes / si	ja / yes / si				
ULTRADUR	ULTRADUR	ALLUNIT-S*	ALLUNIT-S*	ULTRADUR	ULTRADUR	ULTRADUR	ULTRADUR	ALLUNIT-S*	ALLUNIT-S*
2-20	3-20	2-20	3-20	6-20	6-20	3-20	3-20	3-20	3-20
8247	8747	7247	7747	8587	8597	8347	8447	7347	7447
117	117	118	118	119	119	120	120	121	121
									
									
									
									
									
									
									
									
									
									
									
									
									
									

Speedcut 4.0

⁽¹⁾ GFK: glasfaser-verstärkte Kunststoffe | GRP: glass-fibre reinforced plastics | FRP: plastica rinforzata con fibra di vetro

D Übersicht
VHM-Fräser













E Overview
Solid carbide milling cutters

I Sommario
Frese in metallo duro integrale

D Die Schnittwerte für alle Werkzeuge entnehmen Sie bitte unserem separaten Zerspanungshandbuch.

E You will find the cutting conditions for all tools in our separate cutting manual.

I Per i parametri di lavorazione per tutti gli utensili richiedete il nostro manuale tecnico.

	Speedcut 4.0		Speedcut		Speedcut 4.0	Speedcut
						
	NEW	NEW			NEW	
	Inox	Inox	Inox	Inox	Inox	Inox
Norm / Standard	WN				DIN 6527L	
Typ / Type / Tipo	N	N	N	N	N	N
Länge / Length / Lunghezza	XL-freigestellt	XL-freigestellt	XL-freigestellt	XL-freigestellt	lang-freigestellt	lang-freigestellt
Schneidenanzahl / No. of flutes / Nr. denti	4	4	4	4	4	3-4
Kopfform / Head type / Tipo di testa						
Drallwinkel / Spiral angle / Angolo elica	39-42°	39-42°	39-42°	39-42°	39-42°	39-42°
Schaftform / Shank type / Forma codolo	DIN 6535-HA	DIN 6535-HB	DIN 6535-HA	DIN 6535-HB	DIN 6535-HA	DIN 6535-HA
Kühlkanäle / Coolant supply / Fori lubrificazione						
Beschichtung / Coating / Rivestimento	ULTRADUR	ULTRADUR	ALUNIT-S®	ALUNIT-S®	ULTRADUR	ALUNIT-S®
Ø mm	5-20	5-20	5-20	5-20	5-16	2-20
Code / Codice	8267	8767	7267	7767	8647	6547
Seite / Page / Pagina	122	122	123	123	124	125

































































Geeignet für / Suitable for / Adatte per	Speedcut 4.0 (1)	Speedcut 4.0 (2)	Speedcut (1)	Speedcut (2)	Speedcut 4.0 (1)	Speedcut (1)
 Stähle < 400 N/mm² Steels < 400 N/mm ² Acciai < 400 N/mm ²						
 Stähle < 850 N/mm² Steels < 850 N/mm ² Acciai < 850 N/mm ²						
 Stähle < 1.100 N/mm² Steels < 1.100 N/mm ² Acciai < 1.100 N/mm ²						
 Stähle < 1.300 N/mm² Steels < 1.300 N/mm ² Acciai < 1.300 N/mm ²						
 Stähle > 45 HRC Steels > 45 HRC Acciai > 45 HRC						
 INOX < 850 N/mm² Stainless steels < 850 N/mm ² Acciai inossidabili < 850 N/mm ²						
 INOX > 850 N/mm² Stainless steels > 850 N/mm ² Acciai inossidabili > 850 N/mm ²						
 Grauguss, Temperguss Cast iron, malleable cast iron Ghisa grigia, ghisa malleabile						
 Ti Titanium and titanium alloys Titanio e leghe di Titanio						
 Cu, Ms Copper, brass Rame, ottone						
 Al Aluminium Alluminio						
 Kunststoffe Plastics Materie plastiche	 (1)	 (1)	 (1)	 (1)	 (1)	 (1)

(1) GFK: glasfaser-verstärkte Kunststoffe | GRP: glass-fibre reinforced plastics | FRP: plastica rinforzata con fibra di vetro

D Übersicht
VHM-Fräser

E Overview
Solid carbide milling cutters

I Sommario
Frese in metallo duro integrale

Speedcut											
											
HRC	HRC	HRC	HRC	Alu	Alu	Alu	Alu	Alu	Alu	Alu	Alu
DIN 6527L	WN			DIN 6527L				WN			
H	H	H	H	W	W	W	W	W	W	W	W
lang / long	XL-freigestellt	XL	lang-freigestellt	lang-freigestellt	lang-freigestellt	lang-freigestellt	lang-freigestellt	XL-freigestellt	XL-freigestellt	XXL-freigestellt	XXL-freigestellt
6-10	6-10	6-8	6-10	2	2	3-4	3-4	3	3	3	3
											
50°	50°	50°	50°	43-45°	43-45°	34-38°	34-38°	34-38°	34-38°	34-38°	34-38°
DIN 6535-HA	DIN 6535-HA	DIN 6535-HA	DIN 6535-HA	DIN 6535-HA	DIN 6535-HB	DIN 6535-HA	DIN 6535-HB	DIN 6535-HA	DIN 6535-HB	DIN 6535-HA	DIN 6535-HB
ALUNIT-S*	ALUNIT-S*	ALUNIT-S*	ALUNIT-S*								
4-20	4-20	12-16	4-20	3-20	3-20	3-25	3-25	3-20	3-20	3-20	3-20
7277	7287	7287	6647	7035	7135	7250	7950	7220	7920	7290	7990
126	127	127	128	129	129	130	130	131	131	132	132
											
											
											
<68 HRC	<68 HRC	<68 HRC	<68 HRC								
											
											
											
											



D Übersicht
VHM-Fräser

E Overview
Solid carbide milling cutters

I Sommario
Frese in metallo duro integrale

D Die Schnittwerte für alle Werkzeuge entnehmen Sie bitte unserem separaten Zerspanungshandbuch.

E You will find the cutting conditions for all tools in our separate cutting manual.

I Per i parametri di lavorazione per tutti gli utensili richiedete il nostro manuale tecnico.

















































Norm / Standard	DIN 6527L		WN					
Typ / Type / Tipo	W	W	W	W	WR	WR	WR	WR
Länge / Length / Lunghezza	lang-freigestellt	XL-freigestellt	lang-freigestellt	XXL-freigestellt	lang-freigestellt	lang-freigestellt	XL-freigestellt	XL-freigestellt
Schneidenanzahl / No. of flutes / Nr. denti	3	3	2	2	3	3	3	3
Kopfform / Head type / Tipo di testa								
Drallwinkel / Spiral angle / Angolo elica	34-38°	34-38°	43-45°	43-45°	35°	35°	35°	35°
Schaftform / Shank type / Forma codolo	DIN 6535-HA	DIN 6535-HA	DIN 6535-HA	DIN 6535-HA	DIN 6535-HA	DIN 6535-HB	DIN 6535-HA	DIN 6535-HB
Kühlkanäle / Coolant supply / Fori lubrificazione								
Beschichtung / Coating / Rivestimento								
Ø mm	3-16	3-20	3-20	3-20	6-20	6-20	6-20	6-20
Code / Codice	7230	7090	7240	7260	7015	7115	7055	7155
Seite / Page / Pagina	133	134	135	136	137	137	138	138

Geeignet für / Suitable for / Adatte per	1	2	3	4	5	6	7	8
Stähle < 400 N/mm² Steels < 400 N/mm ² Acciai < 400 N/mm ²								
Stähle < 850 N/mm² Steels < 850 N/mm ² Acciai < 850 N/mm ²								
Stähle < 1.100 N/mm² Steels < 1.100 N/mm ² Acciai < 1.100 N/mm ²								
Stähle < 1.300 N/mm² Steels < 1.300 N/mm ² Acciai < 1.300 N/mm ²								
Stähle > 45 HRC Steels > 45 HRC Acciai > 45 HRC								
Rostfreie Stähle < 850 N/mm² Stainless steels < 850 N/mm ² Acciai inossidabili < 850 N/mm ²								
Rostfreie Stähle > 850 N/mm² Stainless steels > 850 N/mm ² Acciai inossidabili > 850 N/mm ²								
Grauguss, Temperguss Cast iron, malleable cast iron Ghisa grigia, ghisa malleabile								
Titan- und Titanlegierung Titanium and titanium alloys Titanio e leghe di Titanio								
Kupfer, Messing Copper, brass Rame, ottone								
Aluminium Aluminium Alluminio								
Kunststoffe Plastics Materie plastiche								

D **Übersicht**
VHM-Fräser

E **Overview**
Solid carbide milling cutters

I **Sommario**
Frese in metallo duro integrale

eco Speedcut		Speedtwister				HSC end mills						
												
Uni	Uni	Uni	Uni	Inox	Inox							
N	N	N	N	N	N	H	H	H	H	H	H	H
kurz-freigestellt	kurz / short	lang-freigestellt	XL	lang-freigestellt	XL	kurz / short	lang / long	kurz / short	lang / long	kurz & lang	kurz & lang	kurz & lang
4	4	5	5	5	5	3-4	3-4	2	2	4	4	2-3
												
35-38°	35-38°	45° VARIO	45° VARIO	45° VARIO	45° VARIO	30°	30°	30°	30°	30°	30°	30°
DIN 6535-HA	DIN 6535-HB	DIN 6535-HB	DIN 6535-HB	DIN 6535-HB	DIN 6535-HB	DIN 6535-HA	DIN 6535-HA	DIN 6535-HA	DIN 6535-HA	DIN 6535-HA	DIN 6535-HA	DIN 6535-HA
ALUNIT-S*	ALUNIT-S*	TWINDUR	TWINDUR	ULTRADUR	ULTRADUR	KUPRADUR	KUPRADUR	KUPRADUR	KUPRADUR	KUPRADUR	KUPRADUR	KUPRADUR
4-12	4-12	3-20	6-16	3-20	6-16	2-16	2-16	3-16	3-12	4-16	4-16	4-16
7627	7127	6117	6137	6107	6197	7110	7210	7060	7160	7030	7010	7010
139	139	140	141	142	143	144	145	146	147	148	149	149
												
												
												
												
												
												
												
												
												
												
												
												
												
												



Speedcut 4.0

D VHM-Schaftfräser Speedcut-Universal,
kurz, freigestellt,
Dreischneider, ungleiche
Drallsteigung

Einsatzbereich:

VHM-Hochleistungsfräser für universellen Einsatz, besonders geeignet zum Nutfräsen und Taschenschruppen. Große Spanräume, aggressiver Schnitt und dynamischer Stirnspanraum zum verbesserten Spanabfluss. Ungleiche Drallsteigung bewirkt ruhigen, vibrationsarmen Lauf. Durch geringere Leistungsaufnahme auch sehr gut geeignet für angetriebene Werkzeuge.

E Solid carbide end mill Speedcut-Universal,
short series, neck, three
flutes, different spiral angles

Range of application:

High performance carbide end mill for universal applications, superbly suitable for slot milling and roughing pockets. High chip space, aggressive cut and dynamic front chip space for optimized chip transportation. Different spiral angles effect smooth, vibrationless running. Due to less power consumption also suitable for driven tools on CNC lathes [MTC].

I Frese frontali MDI Speedcut-Universali,
serie corta, libero, 3 taglianti,
angolo elica disuguale

Impiego:

Frese in MD ad alto rendimento per applicazioni universali, raccomandate per fresatura di scanalature e sgrossatura tasche. Elevato spazio per truciolo, taglio aggressivo e spazio frontale dinamico per ottimizzare l'evacuazione truciolo. Gli angoli di spirale differenziati garantiscono un funzionamento silenzioso e senza vibrazioni.

Speedcut

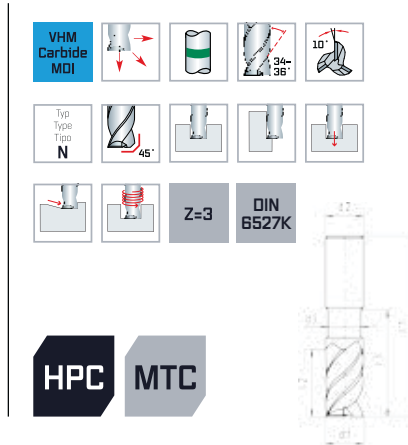
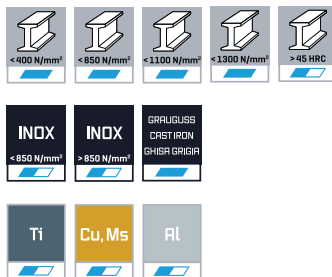

ALLUNIT-S®

d1 _{h10} mm	d2 _{h6} mm	d3 mm	l1 mm	l2 mm	l3 mm		Z	Code 7367 Art.-Nr.
2	4	1,95	40	3	10	0,06	3	0 7367002001 00
3	6	2,8	50	4	11	0,10	3	0 7367003001 00
4	6	3,8	54	5	12	0,10	3	0 7367004001 00
5	6	4,7	54	6	14	0,10	3	0 7367005001 00
6	6	5,6	54	7	16	0,20	3	0 7367006001 00
8	8	7,5	58	9	20	0,20	3	0 7367008001 00
10	10	9,5	66	11	24	0,20	3	0 7367010001 00

Optional ohne Aufpreis auch mit Weldon-Schaft [DIN 6535-HB] lieferbar. | Also available with Weldon-shank [DIN 6535-HB] without extra charge. | Anche disponibili con attacco Weldon [DIN 6535-HB] senza prezzo aggiuntivo.

D VHM-Schafffräser
Speedcut-Universal,
 lang, freigestellt,
 Dreischneider, ungleiche
 Drallsteigung

Einsatzbereich:

VHM-Hochleistungsfräser für universellen Einsatz, besonders geeignet zum Nutfräsen und Taschenschruppen. Große Spanräume, aggressiver Schnitt und dynamischer Stirnspanraum zum verbesserten Spanabfluss. Ungleiche Drallsteigung bewirkt ruhigen, vibrationsarmen Lauf. Durch geringere Leistungsaufnahme auch sehr gut geeignet für angetriebene Werkzeuge.

E Solid carbide end mill
Speedcut-Universal,
 long series, neck, three
 flutes, different spiral angles

Range of application:

High performance carbide end mill for universal applications, superbly suitable for slot milling and roughing pockets. High chip space, aggressive cut and dynamic front chip space for optimized chip transportation. Different spiral angles effect smooth, vibrationless running. Due to less power consumption also suitable for driven tools on CNC lathes [MTC].

I Frese frontali MDI
Speedcut-Universali,
 serie lunga, libero, 3 taglienti,
 angolo elica disuguale

Impiego:

Frese in MD ad alto rendimento per applicazioni universali, raccomandate per fresatura di scanalature e sgrossatura tasche. Elevato spazio per truciolo, taglio aggressivo e spazio frontale dinamico per ottimizzare l'evacuazione truciolo. Gli angoli di spirale differenzia-ti garantiscono un funzionamento silenzioso e senza vibrazioni.

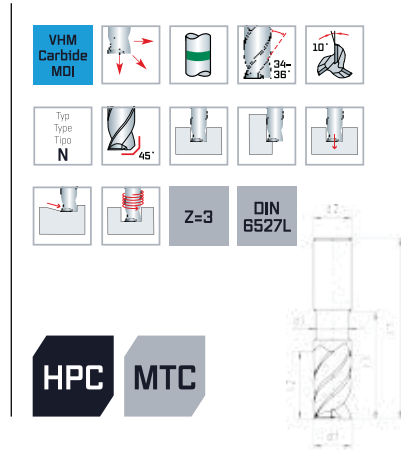
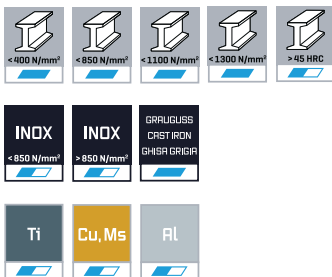

d1 _{h10} mm	d2 _{h6} mm	d3 mm	l1 mm	l2 mm	l3 mm		Z	Code 7377 Art.-Nr.
3	6	2,8	57	7	17	0,10	3	0 7377003001 00
4	6	3,8	57	8	20	0,10	3	0 7377004001 00
5	6	4,7	57	10	22	0,10	3	0 7377005001 00
6	6	5,6	57	13	23	0,20	3	0 7377006001 00
8	8	7,5	63	19	29	0,20	3	0 7377008001 00
10	10	9,5	72	22	34	0,20	3	0 7377010001 00

Optional ohne Aufpreis auch mit Weldon-Schaft [DIN 6535-HB] lieferbar. | Also available with Weldon-shank [DIN 6535-HB] without extra charge. |
 Anche disponibili con attacco Weldon [DIN 6535-HB] senza prezzo aggiuntivo.

D HPC-Schaftfräser
Speedcut 4.0-Universal,
 kurz, Vierschneider,
 ungleiche Drillsteigung

Einsatzbereich:
 VHM-Hochleistungsfräser für universellen Einsatz: Schlichten, Schrupp-Schlichten und Schruppen mit einem Werkzeug. Ungleiche Drillsteigung bewirkt ruhigen, vibrationsarmen Lauf und sehr gute Oberflächengüte. Die Generation 4.0 setzt neue Maßstäbe in der Zerspanungsleistung.

E HPC end mill
Speedcut 4.0-Universal,
 short series, four flutes,
 different spiral angles

Range of application:
 High performance carbide end mill for universal applications. Finishing, rough finishing and roughing with the same tool. Different spiral angles effect smooth, vibrationless running and excellent surface. The Generation 4.0 sets new standards in cutting performance.

I Frese frontali HPC
Speedcut 4.0-Universali,
 serie corta, 4 taglienti,
 angolo elica disuguale

Impiego:
 Frese frontale MDI ad alto rendimento per applicazioni universali. In un solo utensile finitura, semi-finitura e sgrossatura, l'angolo dell'elica disuguale permette una lavorazione silenziosa senza vibrazioni, con un'ottima finitura della superficie. La generazione 4.0 stabilisce nuovi standard in rendimento.

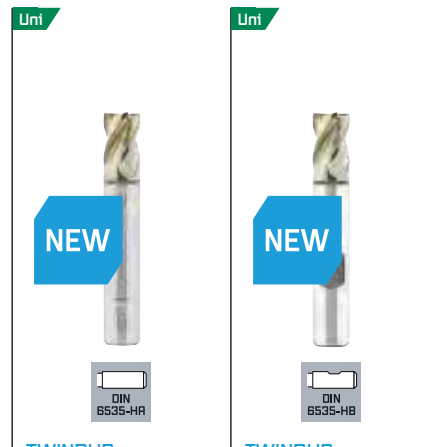
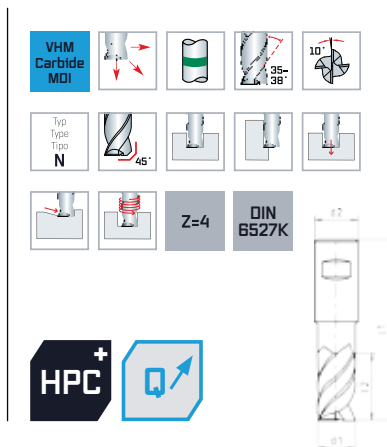
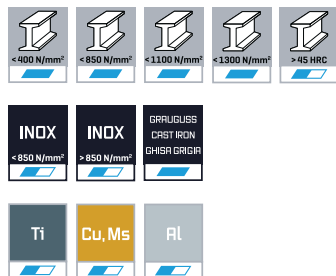

d1 _{h10} mm	d2 _{h6} mm	l1 mm	l2 mm		Z	Code 8207 Art.-Nr.	Code 8707 Art.-Nr.
3	6	50	5	0,15	4	0 8207003001 00	0 8707003001 00
4	6	54	8	0,15	4	0 8207004001 00	0 8707004001 00
5	6	54	9	0,25	4	0 8207005001 00	0 8707005001 00
6	6	54	10	0,25	4	0 8207006001 00	0 8707006001 00
8	8	57	12	0,25	4	0 8207008001 00	0 8707008001 00
10	10	66	14	0,25	4	0 8207010001 00	0 8707010001 00
12	12	73	16	0,25	4	0 8207012001 00	0 8707012001 00
16	16	82	22	0,35	4	0 8207016001 00	0 8707016001 00
20	20	92	26	0,35	4	0 8207020001 00	0 8707020001 00

D VHM-Schafffräser Speedcut-Universal, kurz, Vierschneider, ungleiche Drallsteigung

Einsatzbereich:
VHM-Hochleistungsfräser für universellen Einsatz: Schlichten, Schrupp-Schlichten und Schruppen mit einem Werkzeug. Ungleiche Drallsteigung bewirkt ruhigen, vibrationsarmen Lauf und sehr gute Oberflächengüte. Hohe Zerspansungsleistung.

E Solid carbide end mill Speedcut-Universal, short series, four flutes, different spiral angles

Range of application:
High performance carbide end mill for universal applications. Finishing, rough finishing and roughing with the same tool. Different spiral angles effect smooth, vibrationless running and excellent surface. High cutting performance.

I Frese frontali MDI Speedcut-Universali, serie corta, 4 taglienti, angolo elica disuguale

Impiego:
Frese frontale MDI ad alto rendimento per applicazioni universali. In un solo utensile finitura, semi-finitura e sgrossatura, l'angolo dell'elica disuguale permette una lavorazione silenziosa senza vibrazioni, con un'ottima finitura della superficie. Con un elevato rendimento.

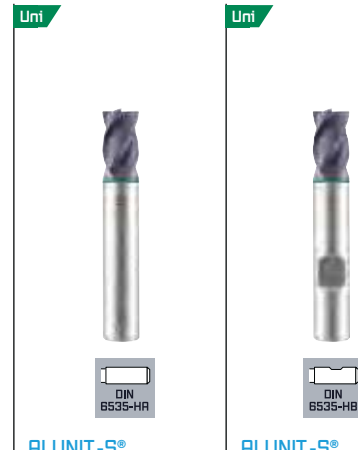
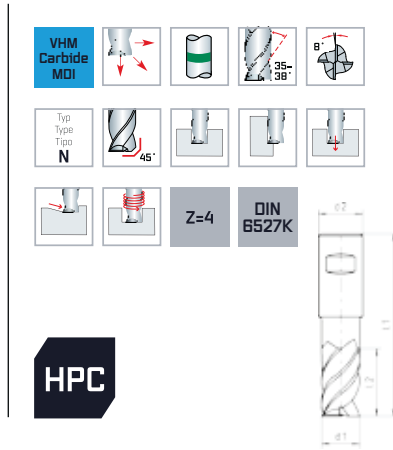

d1 _{h10} mm	d2 _{h6} mm	l1 mm	l2 mm		Z	Code 7207 Art.-Nr.	Code 7707 Art.-Nr.
3	6	50	5	0,15	4	0 7207003001 00	0 7707003001 00
4	6	54	8	0,15	4	0 7207004001 00	0 7707004001 00
5	6	54	9	0,25	4	0 7207005001 00	0 7707005001 00
6	6	54	10	0,25	4	0 7207006001 00	0 7707006001 00
8	8	58	12	0,25	4	0 7207008001 00	0 7707008001 00
10	10	66	14	0,25	4	0 7207010001 00	0 7707010001 00
12	12	73	16	0,25	4	0 7207012001 00	0 7707012001 00
16	16	82	22	0,35	4	0 7207016001 00	0 7707016001 00
20	20	92	26	0,35	4	0 7207020001 00	0 7707020001 00



D VHM-Schaftfräser
Speedcut-Universal,
kurz, freigestellt,
Vierschneider, ungleiche
Drallsteigung

Einsatzbereich:
VHM-Hochleistungsfräser für universellen Einsatz: Schlichten, Schrupp-Schlichten und Schruppen mit einem Werkzeug. Ungleiche Drallsteigung bewirkt ruhigen, vibrationsarmen Lauf und sehr gute Oberflächengüte. Hohe Zerspanungsleistung.

E Solid carbide end mill
Speedcut-Universal,
short series, neck, four
flutes, different spiral angles

Range of application:
High performance carbide end mill for universal applications. Finishing, rough finishing and roughing with the same tool. Different spiral angles effect smooth, vibrationless running and excellent surface. High cutting performance.

I Frese frontali MDI
Speedcut-Universali,
serie corta, libero, 4 taglianti,
angolo elica disuguale

Impiego:
Frese frontale MDI ad alto rendimento per applicazioni universali. In un solo utensile finitura, semi-finitura e sgrossatura, l'angolo dell'elica disuguale permette una lavorazione silenziosa senza vibrazioni, con un'ottima finitura della superficie. Con un elevato rendimento.

Speedcut

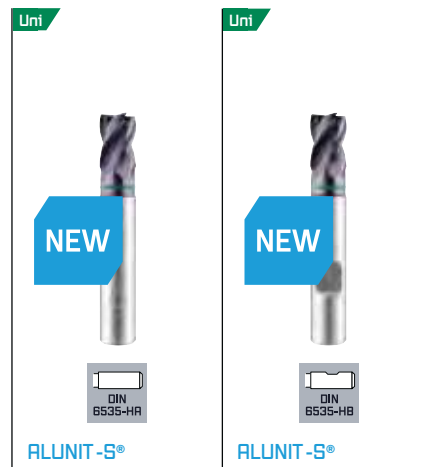
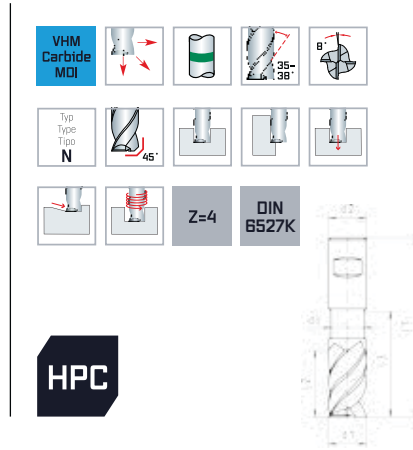
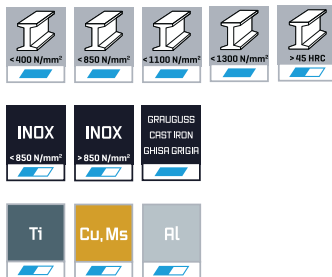

d1 _{h10} mm	d2 _{h6} mm	d3 mm	l1 mm	l2 mm	l3 mm		Z	Code 7387 Art.-Nr.	Code 7487 Art.-Nr.
3	6	2,9	50	5	8	0,15	4	0 7387003001 00	0 7487003001 00
4	6	3,8	54	8	11	0,15	4	0 7387004001 00	0 7487004001 00
5	6	4,7	54	9	13	0,25	4	0 7387005001 00	0 7487005001 00
6	6	5,6	54	10	13	0,25	4	0 7387006001 00	0 7487006001 00
8	8	7,5	57	12	19	0,25	4	0 7387008001 00	0 7487008001 00
10	10	9,5	66	14	22	0,25	4	0 7387010001 00	0 7487010001 00
12	12	11,5	73	16	26	0,25	4	0 7387012001 00	0 7487012001 00
16	16	15,5	82	22	32	0,35	4	0 7387016001 00	0 7487016001 00
20	20	19,5	92	26	38	0,35	4	0 7387020001 00	0 7487020001 00

D HPC-Schaftfräser
Speedcut 4.0-Universal,
 lang, Vierschneider,
 ungleiche Drallsteigung,
 mit Innenkühlung

Einsatzbereich:
 VHM-Hochleistungsfräser für universellen Einsatz: Schlichten, Schrapp-Schlichten und Schruppen mit einem Werkzeug. Ungleiche Drallsteigung bewirkt ruhigen, vibrationsarmen Lauf und sehr gute Oberflächengüte. Die Generation 4.0 setzt neue Maßstäbe in der Zerspanungsleistung.

E HPC end mill
Speedcut 4.0-Universal,
 long series, four flutes,
 different spiral angles, **with**
internal coolant supply

Range of application:
 High performance carbide end mill for universal applications. Finishing, rough finishing and roughing with the same tool. Different spiral angles effect smooth, vibrationless running and excellent surface. The Generation 4.0 sets new standards in cutting performance.

I Frese frontali HPC
Speedcut 4.0-Universali,
 serie lunga, 4 taglienti,
 angolo elica disuguale,
 con fori lubrificazione

Impiego:
 Frese frontale MDI ad alto rendimento per applicazioni universali. In un solo utensile finitura, semi-finitura e sgrossatura, l'angolo dell'elica disuguale permette una lavorazione silenziosa senza vibrazioni, con un'ottima finitura della superficie. La generazione 4.0 stabilisce nuovi standard in rendimento.

Speedcut 4.0

Material compatibility icons showing various materials and their corresponding hardness ranges:

- <math><400\text{ N/mm}^2</math>
- <math><850\text{ N/mm}^2</math>
- <math><1100\text{ N/mm}^2</math>
- <math><1300\text{ N/mm}^2</math>
- >45 HRC
- INOX <math><850\text{ N/mm}^2</math>
- INOX >850 N/mm²
- GRUGUSS CASTIRON GHSA GRIGIR
- Ti
- Cu, Ms
- Al

Technical diagrams and specifications for the HPC end mill:

- VHM Carbide MDI
- Typ Type Tip N
- 45°
- Z=4
- DIN 6527L
- HPC + Q

Product images of TWINDUR end mills, labeled as 'NEW' and 'Uni'. The left image shows a drill with a diameter of 6 mm (DIN 6535-HR), and the right image shows a drill with a diameter of 8 mm (DIN 6535-HB).

d1 h10 mm	d2 h6 mm	l1 mm	l2 mm		Z	Code 8507 Art.-Nr.	Code 8517 Art.-Nr.
6	6	57	13	0,25	4	08507006001 00	08517006001 00
8	8	63	19	0,25	4	08507008001 00	08517008001 00
10	10	72	22	0,25	4	08507010001 00	08517010001 00
12	12	83	26	0,25	4	08507012001 00	08517012001 00
14	14	83	26	0,35	4	08507014001 00	08517014001 00
16	16	92	32	0,35	4	08507016001 00	08517016001 00
20	20	104	38	0,35	4	08507020001 00	08517020001 00

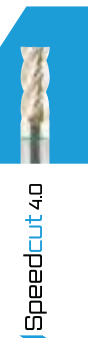

D HPC-Schaftfräser
Speedcut 4.0-Universal,
lang, Vierschneider,
ungleiche Drillsteigung

Einsatzbereich:

VHM-Hochleistungsfräser für universellen Einsatz: Schlichten, Schrupp-Schlichten und Schruppen mit einem Werkzeug. Ungleiche Drillsteigung bewirkt ruhigen, vibrationsarmen Lauf und sehr gute Oberflächengüte. Die Generation 4.0 setzt neue Maßstäbe in der Zerspanungsleistung.

E HPC end mill
Speedcut 4.0-Universal,
long series, four flutes,
different spiral angles

Range of application:

High performance carbide end mill for universal applications. Finishing, rough finishing and roughing with the same tool. Different spiral angles effect smooth, vibrationless running and excellent surface. The Generation 4.0 sets new standards in cutting performance.

I Frese frontali HPC
Speedcut 4.0-Universali,
serie lunga, 4 taglienti,
angolo elica disuguale

Impiego:

Frese frontale MDI ad alto rendimento per applicazioni universali. In un solo utensile finitura, semi-finitura e sgrossatura, l'angolo dell'elica disuguale permette una lavorazione silenziosa senza vibrazioni, con un'ottima finitura della superficie. La generazione 4.0 stabilisce nuovi standard in rendimento.

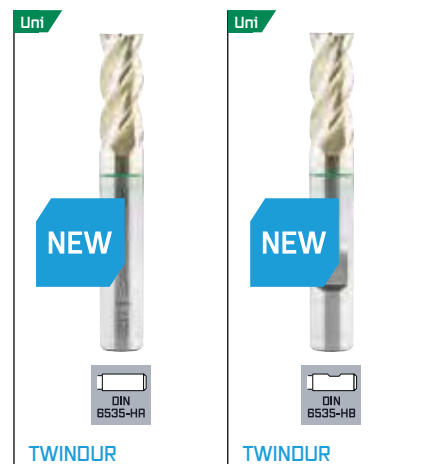
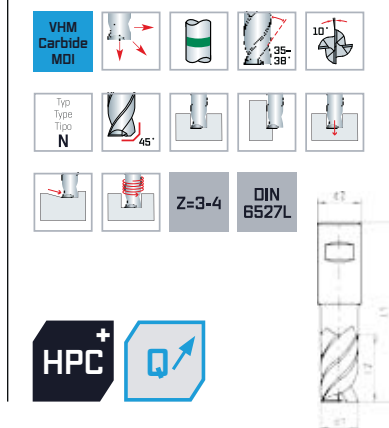
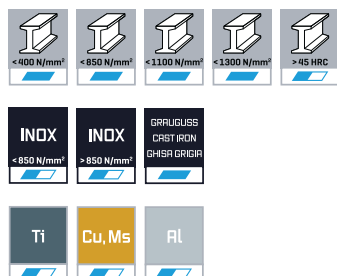

d1 h10 mm	d2 h6 mm	l1 mm	l2 mm		Z	Code 8217 Art.-Nr.	Code 8717 Art.-Nr.
2	4	40	5	0,06	3	0 8217002001 00	
3	6	57	8	0,15	4	0 8217003001 00	0 8717003001 00
4	6	57	11	0,15	4	0 8217004001 00	0 8717004001 00
5	6	57	13	0,25	4	0 8217005001 00	0 8717005001 00
6	6	57	13	0,25	4	0 8217006001 00	0 8717006001 00
7	8	63	16	0,25	4	0 8217007001 00	0 8717007001 00
8	8	63	19	0,25	4	0 8217008001 00	0 8717008001 00
9	10	72	19	0,25	4	0 8217009001 00	0 8717009001 00
10	10	72	22	0,25	4	0 8217010001 00	0 8717010001 00
11	12	83	26	0,25	4	0 8217011001 00	0 8717011001 00
12	12	83	26	0,25	4	0 8217012001 00	0 8717012001 00
16	16	92	32	0,35	4	0 8217016001 00	0 8717016001 00
20	20	104	38	0,35	4	0 8217020001 00	0 8717020001 00

D VHM-Schafffräser
Speedcut-Universal,
 lang, Vierschneider,
 ungleiche Drallsteigung

Einsatzbereich:

VHM-Hochleistungsfräser für universellen Einsatz: Schlichten, Schrapp-Schlichten und Schruppen mit einem Werkzeug. Ungleiche Drallsteigung bewirkt ruhigen, vibrationsarmen Lauf und sehr gute Oberflächengüte. Hohe Zerspanungsleistung.

E Solid carbide end mill
Speedcut-Universal,
 long series, four flutes,
 different spiral angles

Range of application:

High performance carbide end mill for universal applications. Finishing, rough finishing and roughing with the same tool. Different spiral angles effect smooth, vibrationless running and excellent surface. High cutting performance.

I Frese frontali MDI
Speedcut-Universali,
 serie lunga, 4 taglienti,
 angolo elica disuguale

Impiego:

Frese frontale MDI ad alto rendimento per applicazioni universali. In un solo utensile finitura, semi-finitura e sgrossatura, l'angolo dell'elica disuguale permette una lavorazione silenziosa senza vibrazioni, con un'ottima finitura della superficie. Con un elevato rendimento.

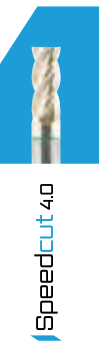
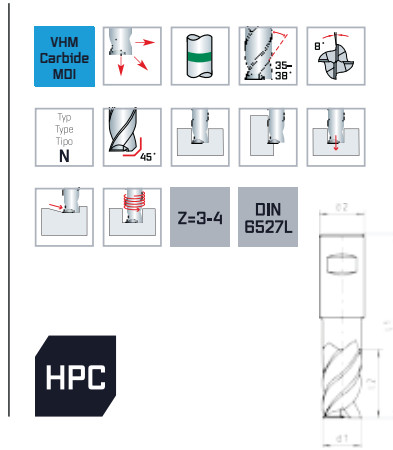
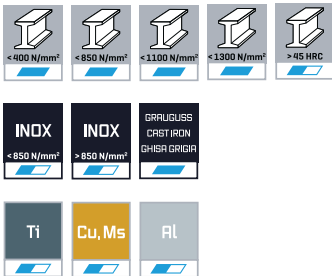

d1 _{h10} mm	d2 _{h6} mm	l1 mm	l2 mm		Z	Code 7217 Art.-Nr.	Code 7717 Art.-Nr.
2	4	40	5	0,06	3	0 7217002001 00	
3	6	57	8	0,15	4	0 7217003001 00	0 7717003001 00
4	6	57	11	0,15	4	0 7217004001 00	0 7717004001 00
5	6	57	13	0,25	4	0 7217005001 00	0 7717005001 00
6	6	57	13	0,25	4	0 7217006001 00	0 7717006001 00
8	8	63	19	0,25	4	0 7217008001 00	0 7717008001 00
10	10	72	22	0,25	4	0 7217010001 00	0 7717010001 00
12	12	83	26	0,25	4	0 7217012001 00	0 7717012001 00
16	16	92	32	0,35	4	0 7217016001 00	0 7717016001 00
20	20	104	38	0,35	4	0 7217020001 00	0 7717020001 00

D HPC-Schaftfräser
Speedcut 4.0-Universal,
 lang, freigestellt, Vierschneider,
 ungleiche Drallsteigung,
 mit Innenkühlung

Einsatzbereich:
 VHM-Hochleistungsfräser für universellen Einsatz: Schlichten, Schrupp-Schlichten und Schruppen mit einem Werkzeug. Ungleiche Drallsteigung bewirkt ruhigen, vibrationsarmen Lauf und sehr gute Oberflächengüte. Die Generation 4.0 setzt neue Maßstäbe in der Zerspanungsleistung.

E HPC end mill
Speedcut 4.0-Universal,
 long series, neck, four flutes,
 different spiral angles, **with**
internal coolant supply

Range of application:
 High performance carbide end mill for universal applications. Finishing, rough finishing and roughing with the same tool. Different spiral angles effect smooth, vibrationless running and excellent surface. The Generation 4.0 sets new standards in cutting performance.

I Frese frontali HPC
Speedcut 4.0-Universali,
 serie lunga, libero, 4 taglianti,
 angolo elica disuguale,
 con fori lubrificazione

Impiego:
 Frese frontale MDI ad alto rendimento per applicazioni universali. In un solo utensile finitura, semi-finitura e sgrossatura, l'angolo dell'elica disuguale permette una lavorazione silenziosa senza vibrazioni, con un'ottima finitura della superficie. La generazione 4.0 stabilisce nuovi standard in rendimento.

Speedcut 4.0

Material compatibility icons:
 <math>< 400 \text{ N/mm}^2</math>
 <math>< 850 \text{ N/mm}^2</math>
 <math>< 1100 \text{ N/mm}^2</math>
 <math>< 1300 \text{ N/mm}^2</math>
 > NS HRC
 INOX <math>< 850 \text{ N/mm}^2</math>
 INOX > 850 N/mm²
 GRANULISS CASTIRON
 GHISA GRIGIA
 Ti, Cu, Ms, Al

Technical diagrams:
 VHM Carbide MDI
 Type T100 N
 45°
 Z=4
 DIN 6527L
 HPC + Q

NEW
 NEW
 TWIN DUR
 TWIN DUR
 DIN 6535-HR
 DIN 6535-HB

d1 _{h10} mm	d2 _{h6} mm	d3 mm	l1 mm	l2 mm	l3 mm		Z	Code 8527 Art.-Nr.	Code 8537 Art.-Nr.
6	6	5,60	57	13	23	0,25	4	0 8527006001 00	0 8537006001 00
8	8	7,50	63	19	29	0,25	4	0 8527008001 00	0 8537008001 00
10	10	9,50	72	22	34	0,25	4	0 8527010001 00	0 8537010001 00
12	12	11,50	83	26	40	0,25	4	0 8527012001 00	0 8537012001 00
14	14	13,50	83	26	40	0,35	4	0 8527014001 00	0 8537014001 00
16	16	15,50	92	32	46	0,35	4	0 8527016001 00	0 8537016001 00
20	20	19,50	104	38	56	0,35	4	0 8527020001 00	0 8537020001 00

D HPC-Schaftfräser
Speedcut 4.0-Universal,
 lang, freigestellt, Vierschneider,
 ungleiche Drallsteigung

E HPC end mill
Speedcut 4.0-Universal,
 long series, neck, four flutes,
 different spiral angles

I Frese frontali HPC
Speedcut 4.0-Universali,
 serie lunga, libero, 4 taglienti,
 angolo elica disuguale

Einsatzbereich:

VHM-Hochleistungsfräser für universellen Einsatz: Schlichten, Schrump-Schlichten und Schruppen mit einem Werkzeug. Ungleiche Drallsteigung bewirkt ruhigen, vibrationsarmen Lauf und sehr gute Oberflächengüte. Die Generation 4.0 setzt neue Maßstäbe in der Zerspanungsleistung.

Range of application:

High performance carbide end mill for universal applications. Finishing, rough finishing and roughing with the same tool. Different spiral angles effect smooth, vibrationless running and excellent surface. The Generation 4.0 sets new standards in cutting performance.

Impiego:

Frese frontale MDI ad alto rendimento per applicazioni universali. In un solo utensile finitura, semi-finitura e sgrossatura, l'angolo dell'elica disuguale permette una lavorazione silenziosa senza vibrazioni, con un'ottima finitura della superficie. La generazione 4.0 stabilisce nuovi standard in rendimento.

Speedcut 4.0

<math><400\text{ N/mm}^2</math>
 <math><850\text{ N/mm}^2</math>
 <math><1100\text{ N/mm}^2</math>
 <math><1300\text{ N/mm}^2</math>
 >45 HRC
 INOX <math><850\text{ N/mm}^2</math>
 INOX >850 N/mm²
 GRAFUGUSS
 CAST IRON
 GHSA GRIGIA
 Ti Cu, Ms Al

VHM Carbide MDI
 Tip Type N
 Z=4
 DIN 6527L
 HPC

Uni
 NEW
 DIN 6535-HR
 TWINDUR
 Uni
 NEW
 DIN 6535-HB
 TWINDUR

d1 _{h10} mm	d2 _{h6} mm	d3 mm	l1 mm	l2 mm	l3 mm		Z	Code 8317 Art.-Nr.	Code 8417 Art.-Nr.
3	6	2,8	57	8	17	0,15	4	0 8317003001 00	0 8417003001 00
4	6	3,8	57	11	20	0,15	4	0 8317004001 00	0 8417004001 00
5	6	4,7	57	13	22	0,25	4	0 8317005001 00	0 8417005001 00
6	6	5,6	57	13	23	0,25	4	0 8317006001 00	0 8417016001 00
8	8	7,5	63	19	29	0,25	4	0 8317008001 00	0 8417018001 00
10	10	9,5	72	22	34	0,25	4	0 8317010001 00	0 8417010001 00
12	12	11,5	83	26	40	0,25	4	0 8317012001 00	0 8417012001 00
14	14	13,5	83	26	40	0,35	4	0 8317014001 00	0 8417014001 00
16	16	15,5	92	32	46	0,35	4	0 8317016001 00	0 8417016001 00
20	20	19,5	104	38	56	0,35	4	0 8317020001 00	0 8417020001 00



D VHM-Schaftfräser Speedcut-Universal,
lang, freigestellt,
Vierschneider, ungleiche
Drallsteigung

Einsatzbereich:
VHM-Hochleistungsfräser für universellen Einsatz: Schlichten, Schrupp-Schlichten und Schruppen mit einem Werkzeug. Ungleiche Drallsteigung bewirkt ruhigen, vibrationsarmen Lauf und sehr gute Oberflächengüte. Hohe Zerspanungsleistung.

E Solid carbide end mill Speedcut-Universal,
long series, neck, four flutes,
different spiral angles

Range of application:
High performance carbide end mill for universal applications. Finishing, rough finishing and roughing with the same tool. Different spiral angles effect smooth, vibrationless running and excellent surface. High cutting performance.

I Frese frontali MDI Speedcut-Universali,
serie lunga, libero, 4 taglienti,
angolo elica disuguale

Impiego:
Frese frontale MDI ad alto rendimento per applicazioni universali. In un solo utensile finitura, semi-finitura e sgrossatura, l'angolo dell'elica disuguale permette una lavorazione silenziosa senza vibrazioni, con un'ottima finitura della superficie. Con un elevato rendimento.

Speedcut

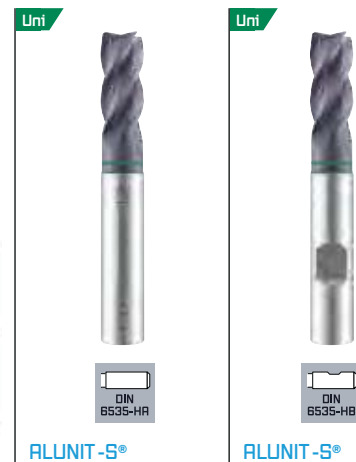
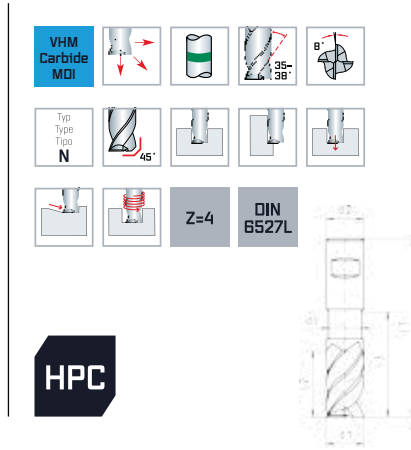
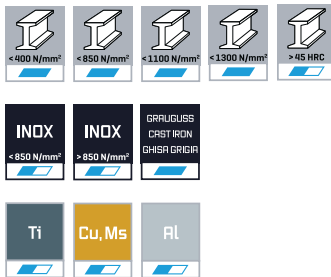

d1 _{h10} mm	d2 _{h6} mm	d3 mm	l1 mm	l2 mm	l3 mm		Z	Code 7317 Art.-Nr.	Code 7417 Art.-Nr.
3	6	2,8	57	8	20	0,15	4	0 7317003001 00	0 7417003001 00
4	6	3,8	57	11	21	0,15	4	0 7317004001 00	0 7417004001 00
5	6	4,7	57	13	22	0,25	4	0 7317005001 00	0 7417005001 00
6	6	5,6	57	13	23	0,25	4	0 7317006001 00	0 7417006001 00
8	8	7,5	63	19	29	0,25	4	0 7317008001 00	0 7417008001 00
10	10	9,5	72	22	34	0,25	4	0 7317010001 00	0 7417010001 00
12	12	11,5	83	26	40	0,25	4	0 7317012001 00	0 7417012001 00
16	16	15,5	92	32	46	0,35	4	0 7317016001 00	0 7417016001 00
20	20	19,5	104	38	56	0,35	4	0 7317020001 00	0 7417020001 00
25	25	24,5	120	45	66	0,35	4	0 7317025001 00	0 7417025001 00

D HPC-Schaftfräser
Speedcut 4.0-Universal,
 extra lang XL, freigestellt,
 Vierschneider, ungleiche
 Drallsteigung

Einsatzbereich:
 VHM-Hochleistungsfräser für universellen Einsatz: Schlichten, Schrapp-Schlichten und Schruppen mit einem Werkzeug. Ungleiche Drallsteigung bewirkt ruhigen, vibrationsarmen Lauf und sehr gute Oberflächengüte. Die Generation 4.0 setzt neue Maßstäbe in der Zerspanungsleistung.

E HPC end mill
Speedcut 4.0-Universal,
 extra long series XL, neck,
 four flutes, different spiral
 angles

Range of application:
 High performance carbide end mill for universal applications. Finishing, rough finishing and roughing with the same tool. Different spiral angles effect smooth, vibrationless running and excellent surface. The Generation 4.0 sets new standards in cutting performance.

I Frese frontali HPC
Speedcut 4.0-Universali,
 serie extra lunga XL, libero,
 4 taglienti, angolo elica
 disuguale

Impiego:
 Frese frontale MDI ad alto rendimento per applicazioni universali. In un solo utensile finitura, semi-finitura e sgrossatura, l'angolo dell'elica disuguale permette una lavorazione silenziosa senza vibrazioni, con un'ottima finitura della superficie. La generazione 4.0 stabilisce nuovi standard in rendimento.

Speedcut 4.0

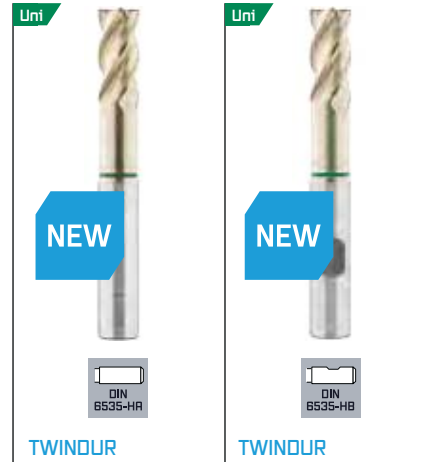
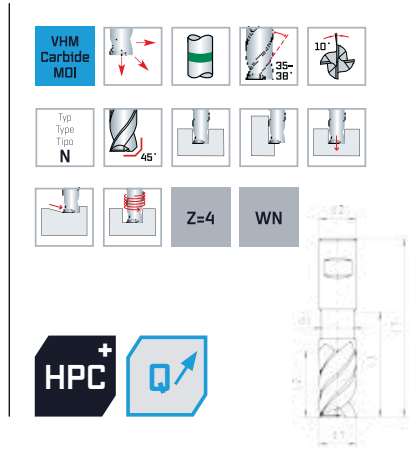
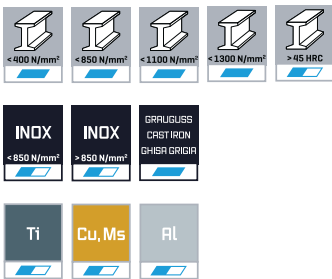

d1 _{h10} mm	d2 _{h6} mm	d3 mm	l1 mm	l2 mm	l3 mm		Z	Code 8237 Art.-Nr.	Code 8737 Art.-Nr.
5	6	4,7	62	13	26	0,25	4	0 8237005001 00	0 8737005001 00
6	6	5,6	62	13	26	0,25	4	0 8237006001 00	0 8737006001 00
8	8	7,5	70	19	34	0,25	4	0 8237008001 00	0 8737008001 00
10	10	9,5	80	22	40	0,25	4	0 8237010001 00	0 8737010001 00
12	12	11,5	95	26	50	0,25	4	0 8237012001 00	0 8737012001 00
16	16	15,5	105	32	57	0,35	4	0 8237016001 00	0 8737016001 00
20	18	19,5	124	38	71	0,35	4	0 8237020001 00	0 8737020001 00



D VHM-Schaftfräser
Speedcut-Universal,
 extra lang XL, freigestellt,
 Vierschneider, ungleiche
 Drallsteigung

Einsatzbereich:
 VHM-Hochleistungsfräser für universellen
 Einsatz: Schlichten, Schrupp-Schlichten und
 Schruppen mit einem Werkzeug. Ungleiche Drall-
 steigung bewirkt ruhigen, vibrationsarmen Lauf
 und sehr gute Oberflächengüte. Hohe Zerspa-
 nungsleistung.

E Solid carbide end mill
Speedcut-Universal,
 extra long series XL, neck,
 four flutes, different spiral
 angles

Range of application:
 High performance carbide end mill for universal
 applications. Finishing, rough finishing and
 roughing with the same tool. Different spiral
 angles effect smooth, vibrationless running and
 excellent surface. High cutting performance.

I Frese frontali MDI
Speedcut-Universali,
 serie extra lunga XL, libero,
 4 taglienti, angolo elica
 disuguale

Impiego:
 Frese frontale MDI ad alto rendimento per applicazio-
 ni universali. In un solo utensile finitura, semi-finitura
 e sgrossatura, l'angolo dell'elica disuguale permette
 una lavorazione silenziosa senza vibrazioni, con
 un'ottima finitura della superficie. Con un elevato
 rendimento.

Speedcut

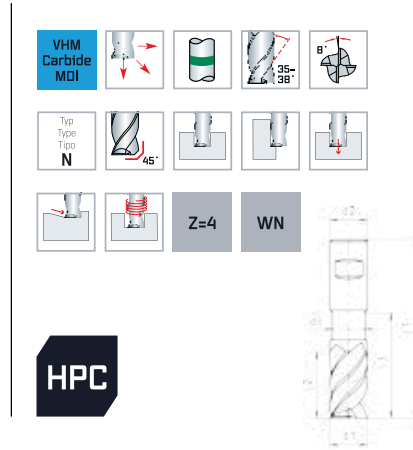
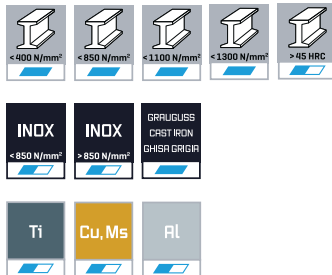

d1 _{h10} mm	d2 _{h6} mm	d3 mm	l1 mm	l2 mm	l3 mm		Z	Code 7237 Art.-Nr.	Code 7737 Art.-Nr.
5	6	4,7	62	13	26	0,25	4	0 7237005001 00	0 7737005001 00
6	6	5,6	62	13	26	0,25	4	0 7237006001 00	0 7737006001 00
8	8	7,5	70	19	34	0,25	4	0 7237008001 00	0 7737008001 00
10	10	9,5	80	22	40	0,25	4	0 7237010001 00	0 7737010001 00
12	12	11,5	95	26	50	0,25	4	0 7237012001 00	0 7737012001 00
14	14	13,5	95	26	50	0,35	4	0 7237014001 00	0 7737014001 00
16	16	15,5	105	32	57	0,35	4	0 7237016001 00	0 7737016001 00
20	20	19,5	124	38	71	0,35	4	0 7237020001 00	0 7737020001 00

**D VHM-Mehrzahl
Schlichtfräser
Speedcut-Universal,
lang**

Einsatzbereich:

VHM-Hochleistungsschlichtfräser für universellen Einsatz in Baustähle, Werkzeugstähle, Vergütungsstähle, aber auch rostfreien Stählen und Titanlegierungen bis 50 HRC.

Durch einen sehr starken Fräserkern und modifiziertem Stirnschliff mit kleiner Eckenschutzfase werden sehr hohe Zerspanungsleistungen mit exzellenter Oberflächengüte erzielt.

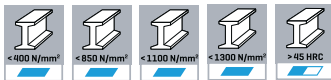

**E Solid carbide multi flute
finishing end mill
Speedcut-Universal,
long series**

Range of application:

High performance carbide finishing end mill for universal applications into structural steels, tool steels, treatable steels but also for stainless steels and titanium alloys up to 50 HRC.

Due to a very strong core and an improved face grinding with small cutting edge chamfer, very high cutting performances with excellent surface quality will be achieved.

**I Fresa in metallo duro
multitagliente per finitura
Speedcut-Universale,
serie lunga**

Impiego:

Fresa a finire in Metallo Duro ad alto rendimento per applicazioni universali idonea per acciai strutturali, acciai da utensili, acciai da tempra ma anche per acciai inossidabili e leghe di titanio fino a 50 HRC. Grazie al nocciolo rinforzato e ad una migliorata superficie rettificata con piccoli smussi di protezione e' possibile raggiungere rendimenti di taglio molto elevati ed eccellenti qualità di finitura.

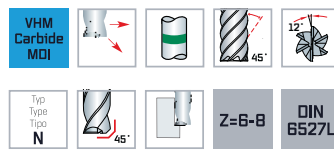

Uni



ALLUNIT-S®

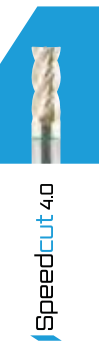

d1 e8 mm	d2 h6 mm	l1 mm	l2 mm		Z	Code 7327 Art.-Nr.
4	6	57	11	0,05	6	0 7327004001 00
5	6	57	13	0,05	6	0 7327005001 00
6	6	57	15	0,05	6	0 7327006001 00
8	8	63	21	0,05	6	0 7327008001 00
10	10	72	25	0,05	6	0 7327010001 00
12	12	83	30	0,05	6	0 7327012001 00
16	16	92	36	0,10	8	0 7327016001 00
20	20	104	45	0,10	8	0 7327020001 00

Optional ohne Aufpreis auch mit Weldon-Schaft [DIN 6535-HB] lieferbar. | Also available with Weldon-shank [DIN 6535-HB] without extra charge. | Anche disponibili con attacco Weldon [DIN 6535-HB] senza prezzo aggiuntivo.

**D VHM-Mehrzahn
Schlichtfräser
Speedcut-Universal,
extra lang XL**

Einsatzbereich:

VHM-Hochleistungsschlichtfräser für universellen Einsatz in Baustählen, Werkzeugstählen, Vergütungsstählen, aber auch rostfreien Stählen und Titanlegierungen bis 50 HRC.

Durch einen sehr starken Fräserkern und modifiziertem Stirnschliff mit kleiner Eckenschutzfase werden sehr hohe Zerspanungsleistungen mit exzellenter Oberflächengüte erzielt.

Speedcut

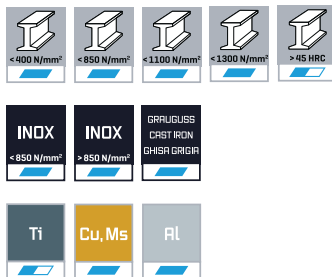

**E Solid carbide multi flute
finishing end mill
Speedcut-Universal,
extra long series XL**

Range of application:

High performance carbide finishing end mill for universal applications into structural steels, tool steels, treatable steels but also for stainless steels and titanium alloys up to 50 HRC.

Due to a very strong core and an improved face grinding with small cutting edge chamfer, very high cutting performances with excellent surface quality will be achieved.



**I Fresa in metallo duro
multitagliente per finitura
Speedcut-Universale,
extra serie lunga XL**

Impiego:

Fresa a finire in Metallo Duro ad alto rendimento per applicazioni universali idonea per acciai strutturali, acciai da utensili, acciai da tempra ma anche per acciai inossidabili e leghe di titanio fino a 50 HRC. Grazie al nocciolo rinforzato e ad una migliorata superficie rettificata con piccoli smussi di protezione e' possibile raggiungere rendimenti di taglio molto elevati ed eccellenti qualita' di finitura.



d1 e8 mm	d2 h6 mm	l1 mm	l2 mm		Z	Code 7337 Art.-Nr.
4	6	57	14	0,05	6	0 7337004001 00
5	6	62	17	0,05	6	0 7337005001 00
6	6	62	20	0,05	6	0 7337006001 00
8	8	70	26	0,05	6	0 7337008001 00
10	10	80	32	0,05	6	0 7337010001 00
12	12	95	38	0,05	6	0 7337012001 00
16	16	105	50	0,10	8	0 7337016001 00
20	20	124	62	0,10	8	0 7337020001 00

Optional ohne Aufpreis auch mit Weldon-Schaft [DIN 6535-HB] lieferbar. | Also available with Weldon-shank [DIN 6535-HB] without extra charge. | Anche disponibili con attacco Weldon [DIN 6535-HB] senza prezzo aggiuntivo.

D HPC-Schaftfräser mit Eckenradius Speedcut 4.0-Universal, lang, freigestellt, Vierschneider, ungleiche Drillsteigung

Einsatzbereich:
VHM-Hochleistungsfräser für universellen Einsatz: Schlichten, Schrupp-Schlichten und Schruppen mit einem Werkzeug. Ungleiche Drillsteigung bewirkt ruhigen, vibrationsarmen Lauf und sehr gute Oberflächengüte. Die Generation 4.0 setzt neue Maßstäbe in der Zerspanungsleistung.

E HPC corner radius end mill Speedcut 4.0-Universal, long series, neck, four flutes, different spiral angles

Range of application:
High performance carbide end mill for universal applications. Finishing, rough finishing and roughing with the same tool. Different spiral angles effect smooth, vibrationless running and excellent surface. The Generation 4.0 sets new standards in cutting performance.

I Frese frontali HPC con spigolo raggato Speedcut 4.0-Universali, serie lunga, libero, 4 taglienti, angolo elica disuguale

Impiego:
Frese frontale MDI ad alto rendimento per applicazioni universali. In un solo utensile finitura, semi-finitura e sgrossatura, l'angolo dell'elica disuguale permette una lavorazione silenziosa senza vibrazioni, con un'ottima finitura della superficie. La generazione 4.0 stabilisce nuovi standard in rendimento.

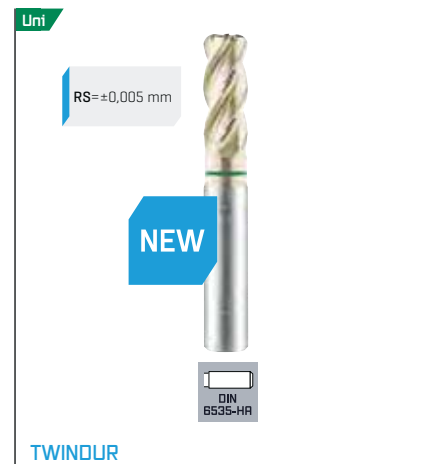
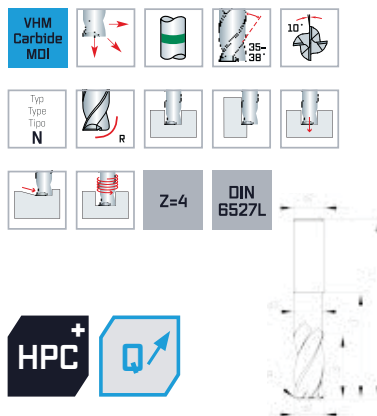
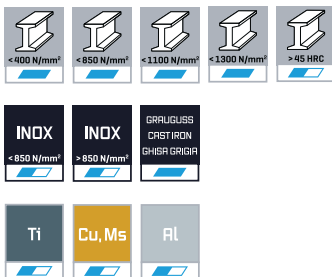

d1 h10 mm	R	d2 h6 mm	d3 mm	l1 mm	l2 mm	l3 mm	Z	Code 8547 Art.-Nr.
6	0,5	6	5,6	57	13	23	4	0 8547006 051 00
	1	6	5,6	57	13	23	4	0 8547006 101 00
	1,5	6	5,6	57	13	23	4	0 8547006 151 00
	2	6	5,6	57	13	23	4	0 8547006 201 00
8	0,5	8	7,5	63	19	29	4	0 8547008 051 00
	1	8	7,5	63	19	29	4	0 8547008 101 00
	1,5	8	7,5	63	19	29	4	0 8547008 151 00
	2	8	7,5	63	19	29	4	0 8547008 201 00
10	0,5	10	9,5	72	22	34	4	0 8547010 051 00
	1	10	9,5	72	22	34	4	0 8547010 101 00
	1,5	10	9,5	72	22	34	4	0 8547010 151 00
	2	10	9,5	72	22	34	4	0 8547010 201 00
12	0,5	12	11,5	83	26	40	4	0 8547012 051 00
	1	12	11,5	83	26	40	4	0 8547012 101 00
	1,5	12	11,5	83	26	40	4	0 8547012 151 00
	2	12	11,5	83	26	40	4	0 8547012 201 00
	2,5	12	11,5	83	26	40	4	0 8547012 251 00
	3	12	11,5	83	26	40	4	0 8547012 301 00

Optional ohne Aufpreis auch mit Weldon-Schaft (DIN 6535-HB) lieferbar. | Also available with Weldon-shank (DIN 6535-HB) without extra charge. | Anche disponibili con attacco Weldon (DIN 6535-HB) senza prezzo aggiuntivo.

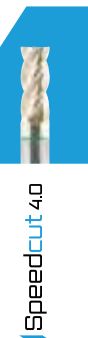

D VHM-Schaftfräser mit Eckenradius Speedcut-Universal, lang, freigestellt, Vierschneider, ungleiche Drallsteigung

Einsatzbereich:
VHM-Hochleistungsfräser für universellen Einsatz: Schlichten, Schrupp-Schlichten und Schruppen mit einem Werkzeug. Ungleiche Drallsteigung bewirkt ruhigen, vibrationsarmen Lauf und sehr gute Oberflächengüte. Hohe Zerspansungsleistung.

Speedcut

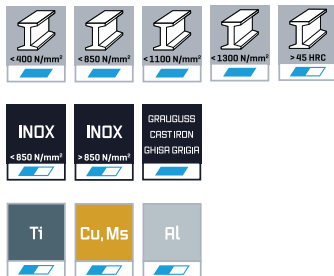

E Solid carbide corner radius end mill Speedcut-Universal, long series, neck, four flutes, different spiral angles

Range of application:
High performance carbide end mill for universal applications. Finishing, rough finishing and roughing with the same tool. Different spiral angles effect smooth, vibrationless running and excellent surface. High cutting performance.

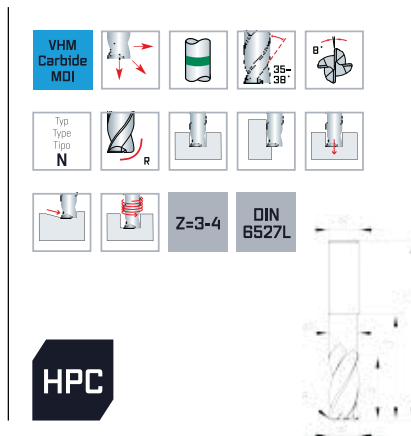

I Frese frontali MDI con spigolo raggaiato Speedcut-Universali, serie lunga, libero, 4 taglienti, angolo elica disuguale

Impiego:
Frese frontale MDI ad alto rendimento per applicazioni universali. In un solo utensile finitura, semi-finitura e sgrossatura, l'angolo dell'elica disuguale permette una lavorazione silenziosa senza vibrazioni, con un'ottima finitura della superficie. Con un elevato rendimento.



ALUNIT-S®

d1 _{h10} mm		d2 _{h6} mm	d3 mm	l1 mm	l2 mm	l3 mm	Z	Code 6447 Art.-Nr.
2	0,2	4	1,95	40	5	10	3	0 6447002021 00
	0,3	4	1,95	40	5	10	3	0 6447002031 00
3	0,3	6	2,9	57	8	20	4	0 6447003031 00
	0,5	6	2,9	57	8	20	4	0 6447003051 00
4	0,5	6	3,8	57	11	20	4	0 6447004051 00
	1	6	3,8	57	11	20	4	0 6447004101 00
5	0,5	6	4,7	57	13	22	4	0 6447005051 00
	1	6	4,7	57	13	22	4	0 6447005101 00
	1,5	6	4,7	57	13	22	4	0 6447005151 00
6	0,5	6	5,6	57	13	23	4	0 6447006051 00
	1	6	5,6	57	13	23	4	0 6447006101 00
	1,5	6	5,6	57	13	23	4	0 6447006151 00
	2	6	5,6	57	13	23	4	0 6447006201 00
8	0,5	8	7,5	63	19	29	4	0 6447008051 00
	1	8	7,5	63	19	29	4	0 6447008101 00
	1,5	8	7,5	63	19	29	4	0 6447008151 00
	2	8	7,5	63	19	29	4	0 6447008201 00
10	0,5	10	9,5	72	22	34	4	0 6447010051 00
	1	10	9,5	72	22	34	4	0 6447010101 00
	1,5	10	9,5	72	22	34	4	0 6447010151 00
	2	10	9,5	72	22	34	4	0 6447010201 00
12	0,5	12	11,5	83	26	40	4	0 6447012051 00
	1	12	11,5	83	26	40	4	0 6447012101 00
	1,5	12	11,5	83	26	40	4	0 6447012151 00
	2	12	11,5	83	26	40	4	0 6447012201 00
	2,5	12	11,5	83	26	40	4	0 6447012251 00
	3	12	11,5	83	26	40	4	0 6447012301 00
16	1	16	15,5	92	32	46	4	0 6447016101 00
	1,5	16	15,5	92	32	46	4	0 6447016151 00
	2	16	15,5	92	32	46	4	0 6447016201 00
	3	16	15,5	92	32	46	4	0 6447016301 00

ALLUNIT-S®

d1 _{h10} mm	 R	d2 _{h6} mm	d3 mm	l1 mm	l2 mm	l3 mm	Z	Code 6447 Art.-Nr.
20	1	20	19,5	104	38	56	4	0 6447020101.00
	1,5	20	19,5	104	38	56	4	0 6447020151.00
	2	20	19,5	104	38	56	4	0 6447020201.00
	2,5	20	19,5	104	38	56	4	0 6447020251.00
	4	20	19,5	104	38	56	4	0 6447020401.00

Optional ohne Aufpreis auch mit Weldon-Schaft [DIN 6535-HB] lieferbar. | Also available with Weldon-shank [DIN 6535-HB] without extra charge. |
Anche disponibili con attacco Weldon [DIN 6535-HB] senza prezzo aggiuntivo.



D VHM-Vollradiusfräser Speedcut-Universal, lang, freigestellt, Vierschneider, ungleiche Drallsteigung

E Solid carbide ballnose end mill Speedcut-Universal, long series, neck, four flutes, different spiral angles

I Frese cilindrica raggiata in metallo duro Speedcut-Universali, serie lunga, libero, 4 taglienti, angolo dell'elica disuguale

Einsatzbereich:
VHM-Hochleistungsfräser für universellen Einsatz: Fein-Schlichten, Schlichten, Schrapp-Schlichten und Schruppen mit einem Werkzeug. Ungleiche Drallsteigung bewirkt ruhigen, vibrationsarmen Lauf und sehr gute Oberflächengüte. Hohe Zerspanungsleistung.

Range of application:
High performance carbide end mill for universal applications. Fine-finishing, finishing, rough finishing and roughing with the same tool. Different spiral angles effect smooth, vibrationless running and excellent surface. High cutting performance.

Impiego:
Frese frontale MDI ad alto rendimento per applicazioni universali. In un solo utensile super finitura, finitura, semi-finitura e sgrossatura, l'angolo dell'elica disuguale permette una lavorazione silenziosa senza vibrazioni, con un'ottima finitura della superficie. Con un elevato rendimento.

Speedcut

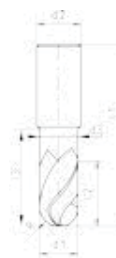
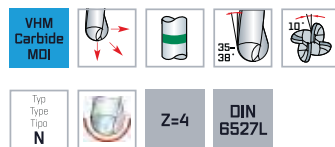
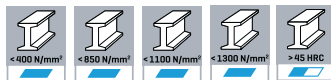

Uni

RS=±0,01 mm



ALUNIT-S®

d1 _{f8} mm	d2 _{h6} mm	d3 mm	l1 mm	l2 mm	l3 mm	R mm	Z	Code 7357 Art.-Nr.
4	6	3,8	57	6	13	2	4	0 7357004001 00
5	6	4,7	57	8	21	2,5	4	0 7357005001 00
6	6	5,6	57	10	21	3	4	0 7357006001 00
8	8	7,5	63	12	27	4	4	0 7357008001 00
10	10	9,5	72	15	32	5	4	0 7357010001 00
12	12	11,5	83	18	38	6	4	0 7357012001 00
16	16	15,5	92	24	44	8	4	0 7357016001 00
20	20	19,5	104	30	54	10	4	0 7357020001 00

Optional ohne Aufpreis auch mit Weldon-Schaft [DIN 6535-HB] lieferbar. | Also available with Weldon-shank [DIN 6535-HB] without extra charge. | Anche disponibili con attacco Weldon [DIN 6535-HB] senza prezzo aggiuntivo.

**D VHM-Vollradiusfräser
Speedcut-Universal,**
extra lang XXL, freigestellt,
Vierschneider, ungleiche
Drallsteigung

Einsatzbereich:

VHM-Hochleistungsfräser für universellen Einsatz: Fein-Schlichten, Schlichten, Schrupp-Schlichten und Schruppen mit einem Werkzeug. Ungleiche Drallsteigung bewirkt ruhigen, vibrationsarmen Lauf und sehr gute Oberflächengüte. Hohe Zerspanungsleistung.

**E Solid carbide
ballnose end mill
Speedcut-Universal,**
extra long series XXL, neck,
four flutes, different spiral
angles

Range of application:

High performance carbide end mill for universal applications. Fine-finishing, finishing, rough finishing and roughing with the same tool. Different spiral angles effect smooth, vibrationless running and excellent surface. High cutting performance.

**I Frese cilindrica raggiata
in metallo duro
Speedcut-Universali,**
serie extra lunga XXL, libero,
4 taglianti, angolo dell'elica
disuguale

Impiego:

Frese frontale MDI ad alto rendimento per applicazioni universali. In un solo utensile super finitura, finitura, semi-finitura e sgrassatura, l'angolo dell'elica disuguale permette una lavorazione silenziosa senza vibrazioni, con un'ottima finitura della superficie. Con un elevato rendimento.

Speedcut

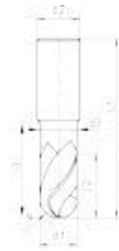
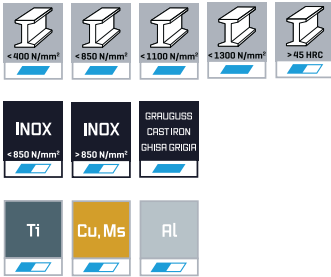

ALUNIT-S®

d1 _{f8} mm	d2 _{h6} mm	d3 mm	l1 mm	l2 mm	l3 mm	R mm	Z	Code 7857 Art.-Nr.
3	6	2,9	59	5	15	1,5	4	0 7857003001 00
4	6	3,9	59	6	20	2	4	0 7857004001 00
5	6	4,9	69	8	25	2,5	4	0 7857005001 00
6	6	5,9	79	10	30	3	4	0 7857006001 00
8	8	7,9	79	12	36	4	4	0 7857008001 00
10	10	9,8	99	15	45	5	4	0 7857010001 00
12	12	11,8	99	18	48	6	4	0 7857012001 00
16	16	15,8	125	24	64	8	4	0 7857016001 00

Optional ohne Aufpreis auch mit Weldon-Schaft [DIN 6535-HB] lieferbar. | Also available with Weldon-shank [DIN 6535-HB] without extra charge. |
Anche disponibili con attacco Weldon [DIN 6535-HB] senza prezzo aggiuntivo.



Speedcut 4.0

D HPC-Schaftfräser
Speedcut 4.0-Inox,
 kurz, freigestellt,
 Vierschneider, ungleiche
 Drallsteigung

Einsatzbereich:
 VHM-Hochleistungsfräser besonders geeignet zur Bearbeitung von austenitischen rostfreien Stählen: Schlichten, Schrupp-Schlichten und Schruppen mit einem Werkzeug. Ungleiche Drallsteigung bewirkt ruhigen, vibrationsarmen Lauf und sehr gute Oberflächengüte. Die Generation 4.0 setzt neue Maßstäbe in der Zerspanungsleistung.

E HPC end mill
Speedcut 4.0-Inox,
 short series, neck, four
 flutes, different spiral angles

Range of application:
 High performance carbide end mill especially suitable for cutting in austenitic stainless steels: Finishing, rough finishing and roughing with the same tool. Different spiral angles effects smooth, vibrationless running and excellent surface. The Generation 4.0 sets new standards in cutting performance.

I Frese frontali HPC
Speedcut 4.0-Inox,
 serie corta, libero, 4 taglianti,
 angolo elica disuguale

Impiego:
 Frese MDI ad alto rendimento, particolarmente adatte per la lavorazione di acciai austenitici inossidabili: Fresatura di finitura, sgrossatura-finitura e sgrossatura con una sola fresa. L'angolo dell'elica disuguale permette una lavorazione silenziosa senza vibrazioni, con un'ottima finitura della superficie. La generazione 4.0 stabilisce nuovi standard in rendimento.

Speedcut 4.0

d1 _{h10} mm	d2 _{h6} mm	d3 mm	l1 mm	l2 mm	l3 mm		Z	Code 8397 Art.-Nr.	Code 8497 Art.-Nr.
3	6	2,9	50	5	8	0,15	4	0 8397003001 00	0 8497003001 00
4	6	3,8	54	8	11	0,15	4	0 8397004001 00	0 8497004001 00
5	6	4,7	54	9	13	0,25	4	0 8397005001 00	0 8497005001 00
6	6	5,6	54	10	13	0,25	4	0 8397006001 00	0 8497006001 00
8	8	7,5	57	12	19	0,25	4	0 8397008001 00	0 8497008001 00
10	10	9,5	66	14	22	0,25	4	0 8397010001 00	0 8497010001 00
12	12	11,5	73	16	26	0,25	4	0 8397012001 00	0 8497012001 00
16	16	15,5	82	22	32	0,35	4	0 8397016001 00	0 8497016001 00

¹⁾ GFK: glasfaser-verstärkte Kunststoffe | GRP: glass-fibre reinforced plastics | FRP: plastica rinforzata con fibra di vetro

D VHM-Schafffräser
Speedcut-Inox,
 kurz, freigestellt, Vier-
 schneider, ungleiche
 Drallsteigung

Einsatzbereich:
 VHM-Hochleistungsfräser besonders geeignet zur Bearbeitung von austenitischen rostfreien Stählen: Schlichten, Schrupp-Schlichten und Schruppen mit einem Werkzeug. Ungleiche Drallsteigung bewirkt ruhigen, vibrationsarmen Lauf und sehr gute Oberflächengüte. Hohe Zerspansungsleistung.

E Solid carbide end mill
Speedcut-Inox,
 short series, neck, four
 flutes, different spiral angles

Range of application:
 High performance carbide end mill especially suitable for cutting in austenitic stainless steels: Finishing, rough finishing and roughing with the same tool. Different spiral angles effects smooth, vibrationless running and excellent surface. High cutting performance.

I Frese frontali MDI
Speedcut-Inox,
 serie corta, libero, 4 taglienti,
 angolo elica disuguale

Impiego:
 Frese MDI ad alto rendimento, particolarmente adatte per la lavorazione di acciai austenitici inossidabili: Fresatura di finitura, sgrossatura-finitura e sgrossatura con una sola fresa. L'angolo dell'elica disuguale permette una lavorazione silenziosa senza vibrazioni, con un'ottima finitura della superficie. Con un elevato rendimento.

Speedcut

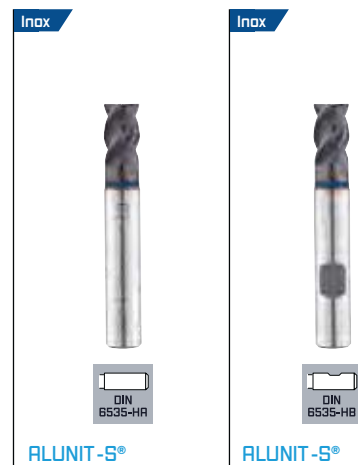
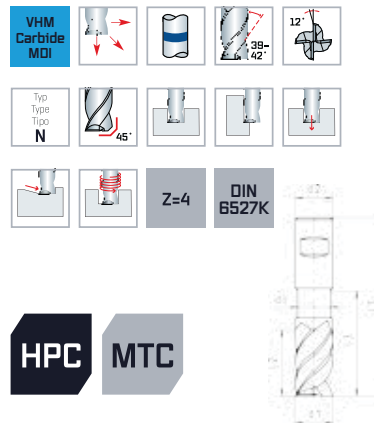
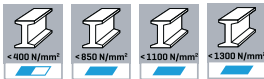

ALUNIT-S®

ALUNIT-S®

d1 _{h10} mm	d2 _{h6} mm	d3 mm	l1 mm	l2 mm	l3 mm		Z	Code 7397 Art.-Nr.	Code 7497 Art.-Nr.
3	6	2,9	50	5	8	0,15	4	0 7397003001 00	0 7497003001 00
4	6	3,8	54	8	11	0,15	4	0 7397004001 00	0 7497004001 00
5	6	4,7	54	9	13	0,25	4	0 7397005001 00	0 7497005001 00
6	6	5,6	54	10	13	0,25	4	0 7397006001 00	0 7497006001 00
8	8	7,5	57	12	19	0,25	4	0 7397008001 00	0 7497008001 00
10	10	9,5	66	14	22	0,25	4	0 7397010001 00	0 7497010001 00
12	12	11,5	73	16	26	0,25	4	0 7397012001 00	0 7497012001 00
16	16	15,5	82	22	32	0,35	4	0 7397016001 00	0 7497016001 00

⁽¹⁾ GFK: glasfaser-verstärkte Kunststoffe | GRP: glass-fibre reinforced plastics | FRP: plastica rinforzata con fibra di vetro

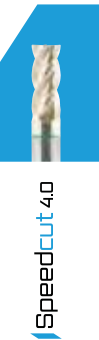

D HPC-Schaftfräser Speedcut 4.0-Inox, lang, Vierschneider, ungleiche Drallsteigung, mit Innenkühlung

Einsatzbereich:
VHM-Hochleistungsfräser besonders geeignet zur Bearbeitung von austenitischen rostfreien Stählen: Schlichten, Schrupp-Schlichten und Schruppen mit einem Werkzeug. Ungleiche Drallsteigung bewirkt ruhigen, vibrationsarmen Lauf und sehr gute Oberflächengüte. Die Generation 4.0 setzt neue Maßstäbe in der Zerspanungsleistung.

E HPC end mill Speedcut 4.0-Inox, long series, four flutes, different spiral angles, with internal coolant supply

Range of application:
High performance carbide end mill especially suitable for cutting in austenitic stainless steels: Finishing, rough finishing and roughing with the same tool. Different spiral angles effects smooth, vibrationless running and excellent surface. The Generation 4.0 sets new standards in cutting performance.

I Frese frontali HPC Speedcut 4.0-Inox, serie lunga, 4 taglienti, angolo elica disuguale, con fori lubrificazione

Impiego:
Frese MDI ad alto rendimento, particolarmente adatte per la lavorazione di acciai austenitici inossidabili: Fresatura di finitura, sgrossatura-finitura e sgrossatura con una sola frese. L'angolo dell'elica disuguale permette una lavorazione silenziosa senza vibrazioni, con un'ottima finitura della superficie. La generazione 4.0 stabilisce nuovi standard in rendimento.

Speedcut 4.0

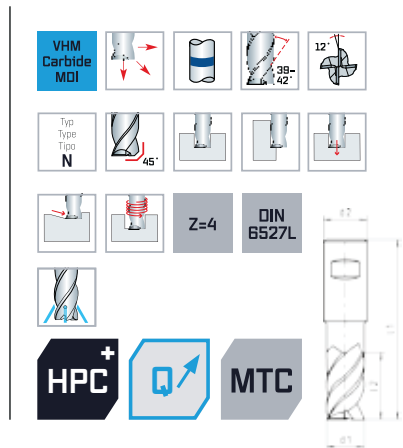

d1 _{h10} mm	d2 _{h6} mm	l1 mm	l2 mm		Z	Code 8557 Art.-Nr.	Code 8567 Art.-Nr.
6	6	57	13	0,25	4	0 8557006001 00	0 8567006001 00
8	8	63	19	0,25	4	0 8557008001 00	0 8567008001 00
10	10	72	22	0,25	4	0 8557010001 00	0 8567010001 00
12	12	83	26	0,25	4	0 8557012001 00	0 8567012001 00
14	14	83	26	0,35	4	0 8557014001 00	0 8567014001 00
16	16	92	32	0,35	4	0 8557016001 00	0 8567016001 00
20	20	104	38	0,35	4	0 8557020001 00	0 8567020001 00

(*) GFK: glasfaser-verstärkte Kunststoffe | GRP: glass-fibre reinforced plastics | FRP: plastica rinforzata con fibra di vetro

D HPC-Schaftfräser
Speedcut 4.0-Inox,
 lang, Vierschneider,
 ungleiche Drallsteigung

E HPC end mill
Speedcut 4.0-Inox,
 long series, four flutes,
 different spiral angles

I Frese frontali HPC
Speedcut 4.0-Inox,
 serie lunga, 4 taglienti, angolo
 elica disuguale

Einsatzbereich:
 VHM-Hochleistungsfräser besonders geeignet zur Bearbeitung von austenitischen rostfreien Stählen: Schlichten, Schrupp-Schlichten und Schruppen mit einem Werkzeug. Ungleiche Drallsteigung bewirkt ruhigen, vibrationsarmen Lauf und sehr gute Oberflächengüte. Die Generation 4.0 setzt neue Maßstäbe in der Zerspanungsleistung.

Range of application:
 High performance carbide end mill especially suitable for cutting in austenitic stainless steels: Finishing, rough finishing and roughing with the same tool. Different spiral angles effects smooth, vibrationless running and excellent surface. The Generation 4.0 sets new standards in cutting performance.

Impiego:
 Frese MDI ad alto rendimento, particolarmente adatte per la lavorazione di acciai austenitici inossidabili: Fresatura di finitura, sgrossatura-finitura e sgrossatura con una sola fresa. L'angolo dell'elica disuguale permette una lavorazione silenziosa senza vibrazioni, con un'ottima finitura della superficie. La generazione 4.0 stabilisce nuovi standard in rendimento.

Speedcut 4.0

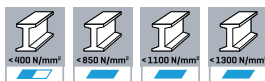

d1 _{h10} mm	d2 _{h6} mm	l1 mm	l2 mm		Z	Code 8247 Art.-Nr.	Code 8747 Art.-Nr.
2	4	40	5	0,06	3	0 8247002001 00	
3	6	57	8	0,15	4	0 8247003001 00	0 8747003001 00
4	6	57	11	0,15	4	0 8247004001 00	0 8747004001 00
5	6	57	13	0,25	4	0 8247005001 00	0 8747005001 00
6	6	57	13	0,25	4	0 8247006001 00	0 8747006001 00
7	8	63	16	0,25	4	0 8247007001 00	0 8747007001 00
8	8	63	19	0,25	4	0 8247008001 00	0 8747008001 00
9	10	72	19	0,25	4	0 8247009001 00	0 8747009001 00
10	10	72	22	0,25	4	0 8247010001 00	0 8747010001 00
11	12	83	26	0,25	4	0 8247011001 00	0 8747011001 00
12	12	83	26	0,25	4	0 8247012001 00	0 8747012001 00
16	16	92	32	0,35	4	0 8247016001 00	0 8747016001 00
20	20	104	38	0,35	4	0 8247020001 00	0 8747020001 00

⁽¹⁾ GFK: glasfaser-verstärkte Kunststoffe | GRP: glass-fibre reinforced plastics | FRP: plastica rinforzata con fibra di vetro



D VHM-Schaftfräser Speedcut-Inox,
lang, Vierschneider,
ungleiche Drallsteigung

E Solid carbide end mill Speedcut-Inox,
long series, four flutes,
different spiral angles

I Frese frontali MDI Speedcut-Inox,
serie lunga, 4 taglienti, angolo
elica disuguale

Einsatzbereich:

VHM-Hochleistungsfräser besonders geeignet zur Bearbeitung von austenitischen rostfreien Stählen: Schlichten, Schrupp-Schlichten und Schruppen mit einem Werkzeug. Ungleiche Drallsteigung bewirkt ruhigen, vibrationsarmen Lauf und sehr gute Oberflächengüte. Hohe Zerspanungsleistung.

Range of application:

High performance carbide end mill especially suitable for cutting in austenitic stainless steels: Finishing, rough finishing and roughing with the same tool. Different spiral angles effects smooth, vibrationless running and excellent surface. High cutting performance.

Impiego:

Frese MDI ad alto rendimento, particolarmente adatte per la lavorazione di acciai austenitici inossidabili: Fresatura di finitura, sgrassatura-finitura e sgrassatura con una sola fresa. L'angolo dell'elica disuguale permette una lavorazione silenziosa senza vibrazioni, con un'ottima finitura della superficie. Con un elevato rendimento.

Speedcut

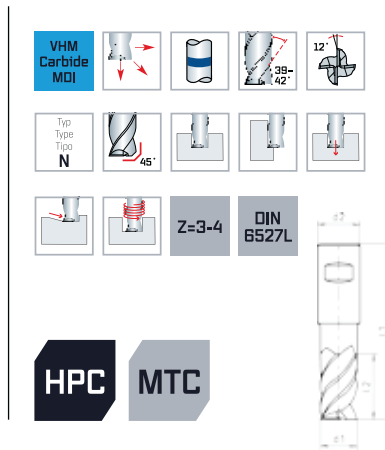
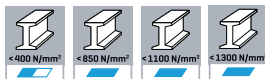

d1 _{h10} mm	d2 _{h6} mm	l1 mm	l2 mm		Z	Code 7247 Art.-Nr.	Code 7747 Art.-Nr.
2	4	40	5	0,06	3	0 7247002001 00	
3	6	57	8	0,15	4	0 7247003001 00	0 7747003001 00
4	6	57	11	0,15	4	0 7247004001 00	0 7747004001 00
5	6	57	13	0,25	4	0 7247005001 00	0 7747005001 00
6	6	57	13	0,25	4	0 7247006001 00	0 7747006001 00
8	8	63	19	0,25	4	0 7247008001 00	0 7747008001 00
10	10	72	22	0,25	4	0 7247010001 00	0 7747010001 00
12	12	83	26	0,25	4	0 7247012001 00	0 7747012001 00
16	16	92	32	0,35	4	0 7247016001 00	0 7747016001 00
20	20	104	38	0,35	4	0 7247020001 00	0 7747020001 00

⁽¹⁾ GFK: glasfaser-verstärkte Kunststoffe | GRP: glass-fibre reinforced plastics | FRP: plastica rinforzata con fibra di vetro

D HPC-Schaftfräser
Speedcut 4.0-Inox,
 lang, freigestellt, Vier-
 schneider, ungleiche Drall-
 steigung, **mit Innenkühlung**

E HPC end mill
Speedcut 4.0-Inox,
 long series, neck, four flutes,
 different spiral angles, **with**
internal coolant supply

I Frese frontali HPC
Speedcut 4.0-Inox,
 serie lunga, libero, 4 taglienti,
 angolo elica disuguale, **con fori**
lubrificazione

Einsatzbereich:

VHM-Hochleistungsfräser besonders geeignet zur Bearbeitung von austenitischen rostfreien Stählen: Schlichten, Schrupp-Schlichten und Schruppen mit einem Werkzeug. Ungleiche Drallsteigung bewirkt ruhigen, vibrationsarmen Lauf und sehr gute Oberflächengüte. Die Generation 4.0 setzt neue Maßstäbe in der Zerspanungsleistung.

Range of application:

High performance carbide end mill especially suitable for cutting in austenitic stainless steels: Finishing, rough finishing and roughing with the same tool. Different spiral angles effects smooth, vibrationless running and excellent surface. The Generation 4.0 sets new standards in cutting performance.

Impiego:

Frese MDI ad alto rendimento, particolarmente adatte per la lavorazione di acciai austenitici inossidabili: Fresatura di finitura, sgrossatura-finitura e sgrossatura con una sola fresa. L'angolo dell'elica disuguale permette una lavorazione silenziosa senza vibrazioni, con un'ottima finitura della superficie. La generazione 4.0 stabilisce nuovi standard in rendimento.

Speedcut 4.0

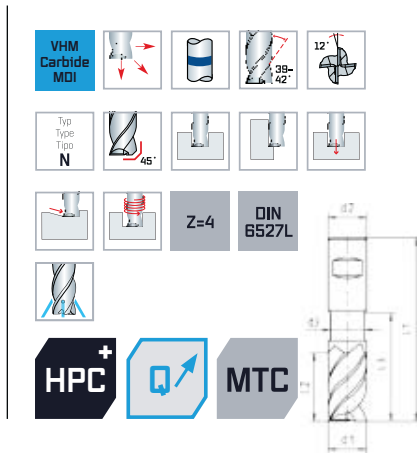
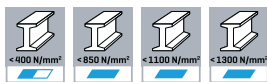

d1 _{h10} mm	d2 _{h6} mm	d3 mm	l1 mm	l2 mm	l3 mm		Z	Code 8587 Art.-Nr.	Code 8597 Art.-Nr.
6	6	5,60	57	13	23	0,25	4	0 8587006001 00	08597006001 00
8	8	7,50	63	19	29	0,25	4	0 8587008001 00	08597008001 00
10	10	9,50	72	22	34	0,25	4	0 8587010001 00	08597010001 00
12	12	11,50	83	26	40	0,25	4	0 8587012001 00	08597012001 00
14	14	13,50	83	26	40	0,35	4	0 8587014001 00	08597014001 00
16	16	15,50	92	32	46	0,35	4	0 8587016001 00	08597016001 00
20	20	19,50	104	38	56	0,35	4	0 8587020001 00	08597020001 00

⁽¹⁾ GFK: glasfaser-verstärkte Kunststoffe | GRP: glass-fibre reinforced plastics | FRP: plastica rinforzata con fibra di vetro

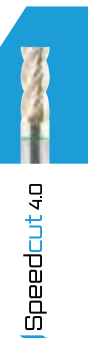

D HPC-Schaftfräser Speedcut 4.0-Inox,
lang, freigestellt, Vier-
schneider, ungleiche
Drallsteigung

Einsatzbereich:

VHM-Hochleistungsfräser besonders geeignet zur Bearbeitung von austenitischen rostfreien Stählen: Schlichten, Schrupp-Schlichten und Schruppen mit einem Werkzeug. Ungleiche Drallsteigung bewirkt ruhigen, vibrationsarmen Lauf und sehr gute Oberflächengüte. Die Generation 4.0 setzt neue Maßstäbe in der Zerspanungsleistung.

E HPC end mill Speedcut 4.0-Inox,
long series, neck, four flutes,
different spiral angles

Range of application:

High performance carbide end mill especially suitable for cutting in austenitic stainless steels: Finishing, rough finishing and roughing with the same tool. Different spiral angles effects smooth, vibrationless running and excellent surface. The Generation 4.0 sets new standards in cutting performance.

I Frese frontali HPC Speedcut 4.0-Inox,
serie lunga, libero, 4 taglienti,
angolo elica disuguale

Impiego:

Frese MDI ad alto rendimento, particolarmente adatte per la lavorazione di acciai austenitici inossidabili: Fresatura di finitura, sgrossatura-finitura e sgrossatura con una sola fresa. L'angolo dell'elica disuguale permette una lavorazione silenziosa senza vibrazioni, con un'ottima finitura della superficie. La generazione 4.0 stabilisce nuovi standard in rendimento.

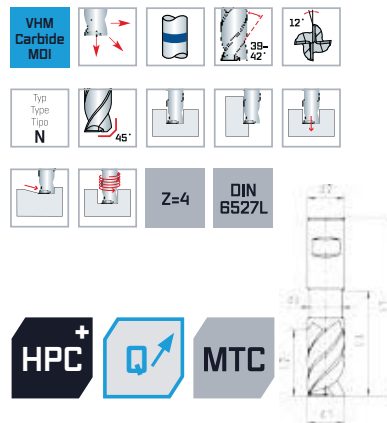
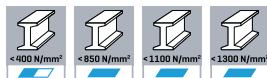

ULTRADUR



ULTRADUR

d1 _{h10} mm	d2 _{h6} mm	d3 mm	l1 mm	l2 mm	l3 mm		Z	Code 8347 Art.-Nr.	Code 8447 Art.-Nr.
3	6	2,8	57	8	20	0,15	4	0 8347003001 00	0 8447003001 00
4	6	3,8	57	11	21	0,15	4	0 8347004001 00	0 8447004001 00
5	6	4,7	57	13	22	0,25	4	0 8347005001 00	0 8447005001 00
6	6	5,6	57	13	23	0,25	4	0 8347006001 00	0 8447006001 00
8	8	7,5	63	19	29	0,25	4	0 8347008001 00	0 8447008001 00
10	10	9,5	72	22	34	0,25	4	0 8347010001 00	0 8447010001 00
12	12	11,5	83	26	40	0,25	4	0 8347012001 00	0 8447012001 00
16	16	15,5	92	32	46	0,35	4	0 8347016001 00	0 8447016001 00
20	20	19,5	104	38	56	0,35	4	0 8347020001 00	0 8447020001 00

⁽¹⁾ GFK: glasfaser-verstärkte Kunststoffe | GRP: glass-fibre reinforced plastics | FRP: plastica rinforzata con fibra di vetro

D VHM-Schafffräser
Speedcut-Inox,
 lang, freigestellt, Vier-
 schneider, ungleiche
 Drallsteigung

Einsatzbereich:

VHM-Hochleistungsfräser besonders geeignet zur Bearbeitung von austenitischen rostfreien Stählen: Schlichten, Schrupp-Schlichten und Schruppen mit einem Werkzeug. Ungleiche Drallsteigung bewirkt ruhigen, vibrationsarmen Lauf und sehr gute Oberflächengüte. Hohe Zerspanungsleistung.

E Solid carbide end mill
Speedcut-Inox,
 long series, neck, four flutes,
 different spiral angles

Range of application:

High performance carbide end mill especially suitable for cutting in austenitic stainless steels: Finishing, rough finishing and roughing with the same tool. Different spiral angles effects smooth, vibrationless running and excellent surface. High cutting performance.

I Frese frontali MDI
Speedcut-Inox,
 serie lunga, libero, 4 taglienti,
 angolo elica disuguale

Impiego:

Frese MDI ad alto rendimento, particolarmente adatte per la lavorazione di acciai austenitici inossidabili: Fresatura di finitura, sgrossatura-finitura e sgrossatura con una sola fresa. L'angolo dell'elica disuguale permette una lavorazione silenziosa senza vibrazioni, con un'ottima finitura della superficie. Con un elevato rendimento.

Speedcut

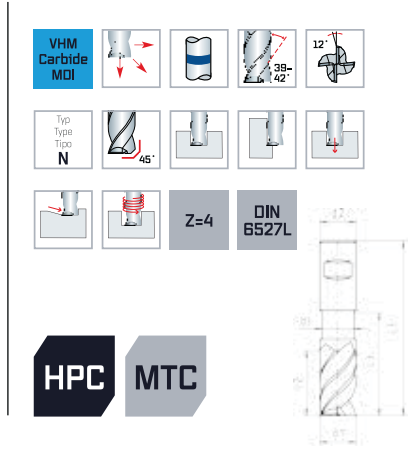

d1 _{h10} mm	d2 _{h6} mm	d3 mm	l1 mm	l2 mm	l3 mm		Z	Code 7347 Art.-Nr.	Code 7447 Art.-Nr.
3	6	2,8	57	8	20	0,15	4	0 7347003001 00	0 7447003001 00
4	6	3,8	57	11	21	0,15	4	0 7347004001 00	0 7447004001 00
5	6	4,7	57	13	22	0,25	4	0 7347005001 00	0 7447005001 00
6	6	5,6	57	13	23	0,25	4	0 7347006001 00	0 7447006001 00
8	8	7,5	63	19	29	0,25	4	0 7347008001 00	0 7447008001 00
10	10	9,5	72	22	34	0,25	4	0 7347010001 00	0 7447010001 00
12	12	11,5	83	26	40	0,25	4	0 7347012001 00	0 7447012001 00
16	16	15,5	92	32	46	0,35	4	0 7347016001 00	0 7447016001 00
20	20	19,5	104	38	56	0,35	4	0 7347020001 00	0 7447020001 00

⁽¹⁾ GFK: glasfaser-verstärkte Kunststoffe | GRP: glass-fibre reinforced plastics | FRP: plastica rinforzata con fibra di vetro

D HPC-Schaftfräser Speedcut 4.0-Inox,
extra lang XL, freigestellt,
Vierschneider, ungleiche
Drallsteigung

Einsatzbereich:
VHM-Hochleistungsfräser besonders geeignet zur Bearbeitung von austenitischen rostfreien Stählen: Schlichten, Schrupp-Schlichten und Schruppen mit einem Werkzeug. Ungleiche Drallsteigung bewirkt ruhigen, vibrationsarmen Lauf und sehr gute Oberflächengüte. Die Generation 4.0 setzt neue Maßstäbe in der Zerspanungsleistung.

E HPC end mill Speedcut 4.0-Inox,
extra long series XL, neck,
four flutes, different spiral
angles

Range of application:
High performance carbide end mill especially suitable for cutting in austenitic stainless steels: Finishing, rough finishing and roughing with the same tool. Different spiral angles effects smooth, vibrationless running and excellent surface. The Generation 4.0 sets new standards in cutting performance.

I Frese frontali HPC Speedcut 4.0-Inox,
serie extra lunga XL, libero,
4 taglienti, angolo elica
disuguale

Impiego:
Frese MDI ad alto rendimento, particolarmente adatte per la lavorazione di acciai austenitici inossidabili: Fresatura di finitura, sgrossatura-finitura e sgrossatura con una sola fresa. L'angolo dell'elica disuguale permette una lavorazione silenziosa senza vibrazioni, con un'ottima finitura della superficie. La generazione 4.0 stabilisce nuovi standard in rendimento.

Speedcut 4.0

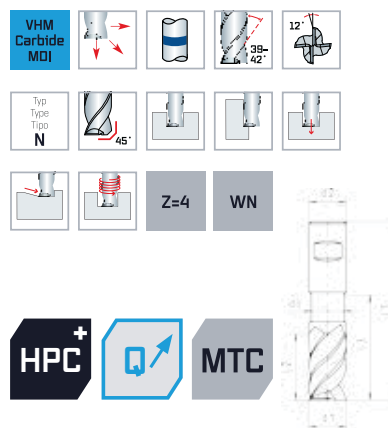

d1 _{h10} mm	d2 _{h6} mm	d3 mm	l1 mm	l2 mm	l3 mm		Z	Code 8267 Art.-Nr.	Code 8767 Art.-Nr.
5	6	4,7	62	13	26	0,25	4	0 8267005001 00	0 8767005001 00
6	6	5,6	62	13	26	0,25	4	0 8267006001 00	0 8767006001 00
8	8	7,5	70	19	34	0,25	4	0 8267008001 00	0 8767008001 00
10	10	9,5	80	22	40	0,25	4	0 8267010001 00	0 8767010001 00
12	12	11,5	95	26	50	0,25	4	0 8267012001 00	0 8767012001 00
16	16	15,5	105	32	57	0,35	4	0 8267016001 00	0 8767016001 00
20	18	19,5	124	38	71	0,35	4	0 8267020001 00	0 8767020001 00

⁽¹⁾ GFRK: glasfaser-verstärkte Kunststoffe | GRP: glass-fibre reinforced plastics | FRP: plastica rinforzata con fibra di vetro

D VHM-Schaftfräser
Speedcut-Inox,
extra lang XL, freigestellt,
Vierschneider, ungleiche
Drallsteigung

Einsatzbereich:
VHM-Hochleistungsfräser besonders geeignet zur Bearbeitung von austenitischen rostfreien Stählen: Schlichten, Schrupp-Schlichten und Schruppen mit einem Werkzeug. Ungleiche Drallsteigung bewirkt ruhigen, vibrationsarmen Lauf und sehr gute Oberflächengüte. Hohe Zerspanungsleistung.

E Solid carbide end mill
Speedcut-Inox,
extra long series XL, neck,
four flutes, different spiral
angles

Range of application:
High performance carbide end mill especially suitable for cutting in austenitic stainless steels: Finishing, rough finishing and roughing with the same tool. Different spiral angles effects smooth, vibrationless running and excellent surface. High cutting performance.

I Frese frontali MDI
Speedcut-Inox,
serie extra lunga XL, libero,
4 taglienti, angolo elica
disuguale

Impiego:
Frese MDI ad alto rendimento, particolarmente adatte per la lavorazione di acciai austenitici inossidabili: Fresatura di finitura, sgrossatura-finitura e sgrossatura con una sola fresa. L'angolo dell'elica disuguale permette una lavorazione silenziosa senza vibrazioni, con un'ottima finitura della superficie. Con un elevato rendimento.

Speedcut

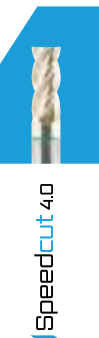
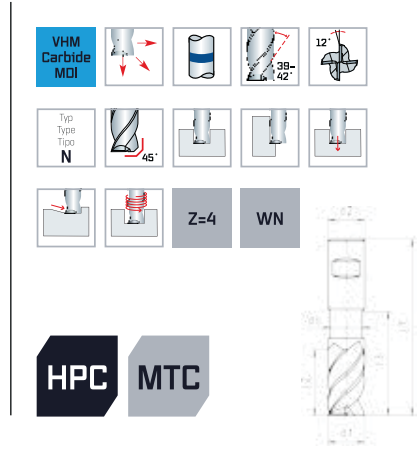

d1 _{h10} mm	d2 _{h6} mm	d3 mm	l1 mm	l2 mm	l3 mm		Z	Code 7267 Art.-Nr.	Code 7767 Art.-Nr.
5	6	4,7	62	13	26	0,25	4	0 7267005001 00	0 7767005001 00
6	6	5,6	62	13	26	0,25	4	0 7267006001 00	0 7767006001 00
8	8	7,5	70	19	34	0,25	4	0 7267008001 00	0 7767008001 00
10	10	9,5	80	22	40	0,25	4	0 7267010001 00	0 7767010001 00
12	12	11,5	95	26	50	0,25	4	0 7267012001 00	0 7767012001 00
16	16	15,5	105	32	57	0,35	4	0 7267016001 00	0 7767016001 00
20	20	19,5	124	38	71	0,35	4	0 7267020001 00	0 7767020001 00

⁽¹⁾ GFK: glasfaser-verstärkte Kunststoffe | GRP: glass-fibre reinforced plastics | FRP: plastica rinforzata con fibra di vetro

D HPC-Schaftfräser mit Eckenradius, Speedcut 4.0-Inox, lang, freigestellt, Vierschneider, ungleiche Drallsteigung

Einsatzbereich:
VHM-Hochleistungsfräser besonders geeignet zur Bearbeitung von austenitischen rostfreien Stählen: Schlichten, Schrupp-Schlichten und Schruppen mit einem Werkzeug. Ungleiche Drallsteigung bewirkt ruhigen, vibrationsarmen Lauf und sehr gute Oberflächengüte. Die Generation 4.0 setzt neue Maßstäbe in der Zerspanungsleistung.

E HPC corner radius end mill Speedcut 4.0-Inox, long series, neck, four flutes, different spiral angles

Range of application:
High performance carbide end mill especially suitable for cutting in austenitic stainless steels: Finishing, rough finishing and roughing with the same tool. Different spiral angles effects smooth, vibrationless running and excellent surface. The Generation 4.0 sets new standards in cutting performance.

I Frese frontali HPC con spigolo raggaiato Speedcut 4.0-Inox, serie lunga, libero, 4 taglienti, angolo elica disuguale

Impiego:
Frese MDI ad alto rendimento, particolarmente adatte per la lavorazione di acciai austenitici inossidabili: Fresatura di finitura, sgrossatura-finitura e sgrossatura con una sola fresa. L'angolo dell'elica disuguale permette una lavorazione silenziosa senza vibrazioni, con un'ottima finitura della superficie. La generazione 4.0 stabilisce nuovi standard in rendimento.

Speedcut 4.0

Inox <math>< 400 \text{ N/mm}^2</math>, <math>< 850 \text{ N/mm}^2</math>, <math>< 1100 \text{ N/mm}^2</math>, <math>< 1300 \text{ N/mm}^2</math>

Inox <math>< 850 \text{ N/mm}^2</math>, $> 850 \text{ N/mm}^2$

Ti, Al, GFK GRP FRP*

VHM Carbide MDI

Typ Type Tipo N

Z=4

DIN 6527L

HPC, Q, MTC

Inox

RS=±0,01 mm

NEW

DIN 6535-HR

ULTRADUR

d1 h10 mm	f_t	d2 h6 mm	d3 mm	l1 mm	l2 mm	l3 mm	Z	Code 8647 Art.-Nr.
5	0,5	6	4,7	57	13	22	4	0 864700505100
	1	6	4,7	57	13	22	4	0 864700510100
6	0,5	6	5,6	57	13	23	4	0 864700605100
	1	6	5,6	57	13	23	4	0 864700610100
	1,5	6	5,6	57	13	23	4	0 864700615100
8	2	6	5,6	57	13	23	4	0 864700620100
	0,5	8	7,5	63	19	29	4	0 864700805100
	1	8	7,5	63	19	29	4	0 864700810100
	1,5	8	7,5	63	19	29	4	0 864700815100
10	2	8	7,5	63	19	29	4	0 864700820100
	0,5	10	9,5	72	22	34	4	0 864701005100
	1	10	9,5	72	22	34	4	0 864701010100
	1,5	10	9,5	72	22	34	4	0 864701015100
12	2	10	9,5	72	22	34	4	0 864701020100
	0,5	12	11,5	83	26	40	4	0 864701205100
	1	12	11,5	83	26	40	4	0 864701210100
	1,5	12	11,5	83	26	40	4	0 864701215100
16	2	12	11,5	83	26	40	4	0 864701220100
	1	16	15,5	92	32	46	4	0 864701610100
	2	16	15,5	92	32	46	4	0 864701620100
	3	16	15,5	92	32	46	4	0 864701630100

* GFK: glasfaser-verstärkte Kunststoffe | GRP: glass-fibre reinforced plastics | FRP: plastica rinforzata con fibra di vetro
Optional ohne Aufpreis auch mit Weldon-Schaft (DIN 6535-HB) lieferbar | Also available with Weldon-shank (DIN 6535-HB) without extra charge. | Anche disponibili con attacco Weldon (DIN 6535-HB) senza prezzo aggiuntivo.

D VHM-Schafffräser mit Eckenradius
Speedcut-Inox,

lang, freigestellt, Vierschneider, ungleiche Drallsteigung

Einsatzbereich:

VHM-Hochleistungsfräser besonders geeignet zur Bearbeitung von austenitischen rostfreien Stählen: Schlichten, Schrupp-Schlichten und Schruppen mit einem Werkzeug. Ungleiche Drallsteigung bewirkt ruhigen, vibrationsarmen Lauf und sehr gute Oberflächengüte. Hohe Zerspanungsleistung.

E Solid carbide corner radius end mill
Speedcut-Inox,

long series, neck, four flutes, different spiral angles

Range of application:

High performance carbide end mill especially suitable for cutting in austenitic stainless steels: Finishing, rough finishing and roughing with the same tool. Different spiral angles effects smooth, vibrationless running and excellent surface. High cutting performance.

I Frese frontali MDI con spigolo raggato
Speedcut-Inox,

serie lunga, libero, 4 taglienti, angolo elica disuguale

Impiego:

Frese MDI ad alto rendimento, particolarmente adatte per la lavorazione di acciai austenitici inossidabili: Fresatura di finitura, sgrossatura-finitura e sgrossatura con una sola fresa. L'angolo dell'elica disuguale permette una lavorazione silenziosa senza vibrazioni, con un'ottima finitura della superficie. Con un elevato rendimento.

Speedcut

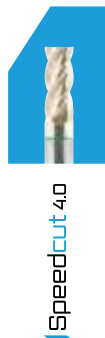

d1 _{h10} mm	R	d2 _{h6} mm	d3 mm	l1 mm	l2 mm	l3 mm	Z	Code 6547 Art.-Nr.
2	0,2	4	1,95	40	5	10	3	0 6547002021 00
	0,3	6	2,9	57	8	20	4	0 6547003031 00
3	0,5	6	2,9	57	8	20	4	0 6547003051 00
	0,5	6	3,8	57	11	21	4	0 6547004051 00
4	1	6	3,8	57	11	21	4	0 6547004101 00
	0,5	6	4,7	57	13	22	4	0 6547005051 00
5	1	6	4,7	57	13	22	4	0 6547005101 00
	0,5	6	5,6	57	13	23	4	0 6547006051 00
6	1	6	5,6	57	13	23	4	0 6547006101 00
	2	6	5,6	57	13	23	4	0 6547006201 00
8	0,5	8	7,5	63	19	29	4	0 6547008051 00
	1	8	7,5	63	19	29	4	0 6547008101 00
	1,5	8	7,5	63	19	29	4	0 6547008151 00
10	2	8	7,5	63	19	29	4	0 6547008201 00
	0,5	10	9,5	72	22	34	4	0 6547010051 00
	1	10	9,5	72	22	34	4	0 6547010101 00
12	1,5	10	9,5	72	22	34	4	0 6547010151 00
	2	10	9,5	72	22	34	4	0 6547010201 00
	0,5	12	11,5	83	26	40	4	0 6547012051 00
16	1	12	11,5	83	26	40	4	0 6547012101 00
	1,5	12	11,5	83	26	40	4	0 6547012151 00
	2	12	11,5	83	26	40	4	0 6547012201 00
20	1	16	15,5	92	32	46	4	0 6547016101 00
	2	16	15,5	92	32	46	4	0 6547016201 00
	3	16	15,5	92	32	46	4	0 6547016301 00
20	1	20	19,5	104	38	56	4	0 6547020101 00
	2	20	19,5	104	38	56	4	0 6547020201 00
	3	20	19,5	104	38	56	4	0 6547020301 00

(1) GFK: glasfaser-verstärkte Kunststoffe | GRP: glass-fibre reinforced plastics | FRP: plastica rinforzata con fibra di vetro
Optional ohne Aufpreis auch mit Weldon-Schaft [DIN 6535-HB] lieferbar. | Also available with Weldon-shank [DIN 6535-HB] without extra charge. |
Anche disponibili con attacco Weldon [DIN 6535-HB] senza prezzo aggiuntivo.

D VHM-Schaftfräser
Speedcut-Ultra Hard Steel
68 HRC,
 lang

Einsatzbereich:

VHM-Hochleistungsschichtfräser speziell geeignet für die Bearbeitung von gehärteten und hochfesten Stählen. Die hohe Steifigkeit ermöglicht große Vorschübe und lange Standzeiten, der hohe Drallwinkel bewirkt dabei eine sehr gute Oberflächengüte am Werkstück. Verwendet wird der Fräser zum Umfangfräsen (Schichten). Bei geringen Tiefen ist auch ein Stirnschnitt möglich, wobei der Vorschub um 50% zu verringern ist.

Speedcut

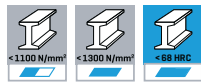

E Solid carbide end mill
Speedcut-Ultra Hard Steel
68 HRC,
 long series

Range of application:

High performance carbide end mill especially suitable for machining hardened and high tensile steels. The high level of stiffness enables good feed rates and long service lives, whilst the spiral angle creates a very good surface quality on the work piece. The cutter is used for circumferential milling (finishing). For shallow depths, a face cut is also possible, in which case the feed rate should be reduced by 50%.



I Frese frontali MDI
Speedcut-Ultra Hard Steel
68 HRC,
 serie lunga

Impiego:

Frese MDI ad alto rendimento per la lavorazione di acciai temprati e di elevata durezza. La notevole rigidità consente grandi avanzamenti e lunga durata, l'elevato angolo dell'elica garantisce ottima qualità delle superfici sul pezzo lavorato. La fresa è indicata per eseguire contornature (fresa a finire). In caso di basse profondità di lavorazione, è anche possibile eseguire tagli frontali, riducendo però l'avanzamento del 50%.



d1 _{e8} mm	d2 _{h5} mm	l1 mm	l2 mm		Z	Code 7277 Art.-Nr.
4	6	57	11	0,05	6	0 7277004001 00
5	6	57	13	0,05	6	0 7277005001 00
6	6	57	13	0,05	6	0 7277006001 00
8	8	63	19	0,05	6	0 7277008001 00
10	10	72	22	0,05	6	0 7277010001 00
12	12	83	26	0,05	6	0 7277012001 00
14	14	83	26	0,10	6	0 7277014001 00
16	16	92	32	0,10	8	0 7277016001 00
20	20	104	38	0,10	10	0 7277020001 00

Optional ohne Aufpreis auch mit Weldon-Schaft [DIN 6535-HB] lieferbar. | Also available with Weldon-shank [DIN 6535-HB] without extra charge. | Anche disponibili con attacco Weldon [DIN 6535-HB] senza prezzo aggiuntivo.

D VHM-Schaftfräser
Speedcut-Ultra Hard Steel
68 HRC,
 extra lang XL, freigestellt

Einsatzbereich:

VHM-Hochleistungsschichtfräser speziell geeignet für die Bearbeitung von gehärteten und hochfesten Stählen. Die hohe Steifigkeit ermöglicht große Vorschübe und lange Standzeiten, der hohe Drallwinkel bewirkt dabei eine sehr gute Oberflächengüte am Werkstück. Verwendet wird der Fräser zum Umfangfräsen (Schlichten). Bei geringen Tiefen ist auch ein Stirnschnitt möglich, wobei der Vorschub um 50% zu verringern ist.



E Solid carbide end mill
Speedcut-Ultra Hard Steel
68 HRC,
 extra long series XL, neck

Range of application:

High performance carbide end mill especially suitable for machining hardened and high tensile steels. The high level of stiffness enables good feed rates and long service lives, whilst the spiral angle creates a very good surface quality on the work piece. The cutter is used for circumferential milling [finishing]. For shallow depths, a face cut is also possible, in which case the feed rate should be reduced by 50%.



I Frese frontali MDI
Speedcut-Ultra Hard Steel
68 HRC,
 serie extra lunga XL, libero

Impiego:

Frese MDI ad alto rendimento per la lavorazione di acciai temprati e di elevata durezza. La notevole rigidità consente grandi avanzamenti e lunga durata, l'elevato angolo dell'elica garantisce ottima qualità delle superfici sul pezzo lavorato. La fresa è indicata per eseguire contornature (fresa a finire). In caso di basse profondità di lavorazione, è anche possibile eseguire tagli frontali, riducendo però l'avanzamento del 50%.



d1 _{e8} mm	d2 _{h5} mm	d3 mm	l1 mm	l2 mm	l3 mm		Z	Code 7287 Art.-Nr.
4	6	3,8	57	11	20	0,05	6	0 7287004001 00
5	6	4,7	62	13	25	0,05	6	0 7287005001 00
6	6	5,6	62	13	25	0,05	6	0 7287006001 00
8	8	7,5	70	19	32	0,05	6	0 7287008001 00
10	10	9,5	80	22	40	0,05	6	0 7287010001 00
12	12	11,5	95	26	48	0,05	6	0 7287012001 00
14	14	13,5	95	26	48	0,10	6	0 7287014001 00
16	16	15,5	105	32	56	0,10	8	0 7287016001 00
20	20	19,5	124	38	70	0,10	10	0 7287020001 00



d1 _{e8} mm	d2 _{h5} mm	d3 mm	l1 mm	l2 mm	l3 mm		Z	Code 7287 Art.-Nr.
12	12	-	95	38	-	0,05	6	0 7287012101 00
16	16	-	105	50	-	0,10	8	0 7287016101 00

Optional ohne Aufpreis auch mit Weldon-Schaft (DIN 6535-HB) lieferbar. | Also available with Weldon-shank (DIN 6535-HB) without extra charge. |
 Anche disponibili con attacco Weldon (DIN 6535-HB) senza prezzo aggiuntivo.

D VHM-Schaftfräser mit Eckenradius Speedcut-Ultra Hard Steel 68 HRC, lang, freigestellt

Einsatzbereich:

VHM-Hochleistungsschichtfräser speziell geeignet für die Bearbeitung von gehärteten und hochfesten Stählen. Die hohe Steifigkeit ermöglicht große Vorschübe und lange Standzeiten, der hohe Drallwinkel bewirkt dabei eine sehr gute Oberflächengüte am Werkstück. Verwendet wird der Fräser zum Umfangfräsen (Schlichten). Bei geringen Tiefen ist auch ein Stirnschnitt möglich, wobei der Vorschub um 50% zu verringern ist.

Speedcut



E Solid carbide corner radius end mill Speedcut-Ultra Hard Steel 68 HRC, long series, neck

Range of application:

High performance carbide end mill especially suitable for machining hardened and high tensile steels. The high level of stiffness enables good feed rates and long service lives, whilst the spiral angle creates a very good surface quality on the work piece. The cutter is used for circumferential milling (finishing). For shallow depths, a face cut is also possible, in which case the feed rate should be reduced by 50%.



I Frese frontali MDI con spigolo raggato Speedcut-Ultra Hard Steel 68 HRC, serie lunga, libero

Impiego:

Frese MDI ad alto rendimento per la lavorazione di acciai temprati e di elevata durezza. La notevole rigidità consente grandi avanzamenti e lunga durata, l'elevato angolo dell'elica garantisce ottima qualità delle superfici sul pezzo lavorato. La fresa è indicata per eseguire contornature (fresa a finire). In caso di basse profondità di lavorazione, è anche possibile eseguire tagli frontali, riducendo però l'avanzamento del 50%.



ALLUNIT-S®

d1 e8 mm	R	d2 h5 mm	d3 mm	l1 mm	l2 mm	l3 mm	Z	Code 6647 Art.-Nr.
4	0,5	6	3,9	57	6	10	6	0 6647004051 00
5	0,5	6	4,9	57	8	12	6	0 6647005051 00
6	0,5	6	5,9	57	10	15	6	0 6647006051 00
8	0,5	8	7,8	63	13	21	6	0 6647008051 00
10	0,5	10	9,8	72	16	25	6	0 6647010051 00
	1,0	10	9,8	72	16	25	6	0 6647010101 00
12	0,5	12	11,8	83	19	30	6	0 6647012051 00
	1,0	12	11,8	83	19	30	6	0 6647012101 00
16	0,5	16	15,8	92	25	38	8	0 6647016051 00
	1,0	16	15,8	92	25	38	8	0 6647016101 00
20	1,0	20	19,8	104	31	45	10	0 6647020101 00

Optional ohne Aufpreis auch mit Weldon-Schaft (DIN 6535-HB) lieferbar. | Also available with Weldon-shank (DIN 6535-HB) without extra charge. | Anche disponibili con attacco Weldon (DIN 6535-HB) senza prezzo aggiuntivo.

D VHM-Schafffräser
Speedcut-Aluminium,
 lang, freigestellt,
 Zweischneider, ungleiche
 Drallsteigung

Einsatzbereich:

VHM-Hochleistungsfräser besonders geeignet zur Bearbeitung von Aluminium-Werkstoffen (sowohl für Guss- als auch Knetlegierungen). Kernantrieb für höchste Stabilität, bester Spanabfluss durch optimiertes Fertigungs-Schleifverfahren, dadurch extrem glatte Oberfläche. Höchstes Zerspanvolumen und beste Oberflächengüte durch einzigartige Schneidengeometrie.

E Solid carbide end mill
Speedcut-Aluminium,
 long series, neck,
 two flutes, different spiral
 angles

Range of application:

Solid carbide high performance end mill especially suitable for aluminium. Center web for highest stability, excellent chip breakage and chip transportation due to optimized manufacturing-grinding method, that is why extremely smooth surface. Highest cutting volume and superior surface quality due to unique cutting edge geometry.

I Frese frontali MDI
Speedcut-Alluminio,
 serie lunga, libero, 2 taglienti,
 angolo elica disuguale

Impiego:

Fresa frontale MDI ad alto rendimento particolarmente adatta per alluminio. Nocciolo crescente per una maggiore stabilità, eccellente rottura ed evacuazione del truciolo grazie al processo di rettifica ottimizzato che rende la superficie dell'utensile estremamente liscia. Volumi asportati elevati ed eccellente qualità della superficie ottenuta grazie alla unicità della geometria dei taglienti.

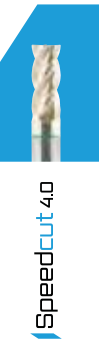
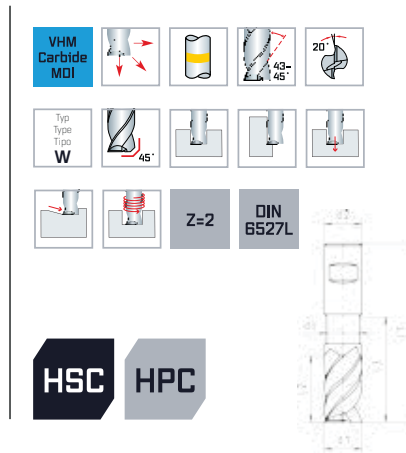

d1 _{h10} mm	d2 _{h6} mm	d3 mm	l1 mm	l2 mm	l3 mm		Z	Code 7035 Art.-Nr.	Code 7135 Art.-Nr.
3	6	2,8	57	8	16	0,05	2	0 7035003001 00	0 7135003001 00
4	6	3,8	57	11	18	0,06	2	0 7035004001 00	0 7135004001 00
5	6	4,7	57	13	20	0,06	2	0 7035005001 00	0 7135005001 00
6	6	5,6	57	13	20	0,08	2	0 7035006001 00	0 7135006001 00
8	8	7,5	63	19	25	0,10	2	0 7035008001 00	0 7135008001 00
10	10	9,5	72	22	30	0,15	2	0 7035010001 00	0 7135010001 00
12	12	11,5	83	26	36	0,15	2	0 7035012001 00	0 7135012001 00
16	16	15,5	92	32	42	0,20	2	0 7035016001 00	0 7135016001 00
20	20	19,5	104	38	52	0,25	2	0 7035020001 00	0 7135020001 00

D VHM-Schaftfräser Speedcut-Aluminium,
lang, freigestellt,
Dreischneider, ungleiche
Drallsteigung

Einsatzbereich:
VHM-Hochleistungsfräser besonders geeignet zur Bearbeitung von Aluminium-Werkstoffen (sowohl für Guss- als auch Knetlegierungen). Kernanstieg für höchste Stabilität, bester Spanabfluss durch optimiertes Fertigungs-Schleifverfahren, dadurch extrem glatte Oberfläche. Höchstes Zerspanvolumen und beste Oberflächengüte durch einzigartige Schneidengeometrie.

Speedcut



E Solid carbide end mill Speedcut-Aluminium,
long series, neck,
three flutes, different spiral
angles

Range of application:
Solid carbide high performance end mill especially suitable for aluminium. Center web for highest stability, excellent chip breakage and chip transportation due to optimized manufacturing-grinding method, that is why extremely smooth surface. Highest cutting volume and superior surface quality due to unique cutting edge geometry.

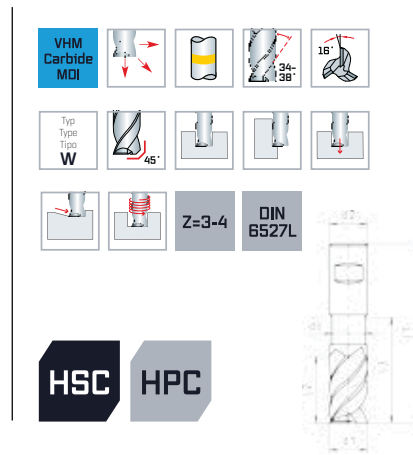

I Frese frontali MDI Speedcut-Alluminio,
serie lunga, libero, 3 taglianti,
angolo elica disuguale

Impiego:
Fresa frontale MDI ad alto rendimento particolarmente adatta per alluminio. Nocciolo crescente per una maggiore stabilità, eccellente rottura ed evacuazione del truciolo grazie al processo di rettifica ottimizzato che rende la superficie dell'utensile estremamente liscia. Volumi asportati elevati ed eccellente qualità della superficie ottenuta grazie alla unicità della geometria dei taglianti.

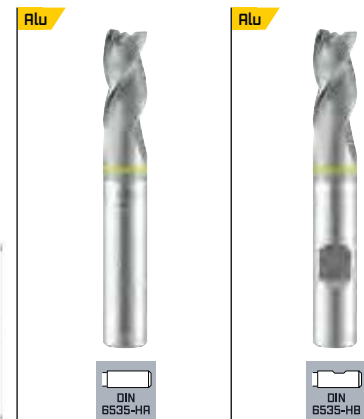

d1 _{h10} mm	d2 _{h6} mm	d3 mm	l1 mm	l2 mm	l3 mm		Z	Code 7250 Art.-Nr.	Code 7950 Art.-Nr.
3	6	2,8	57	8	16	0,05	3	0 7250003001 00	0 7950003001 00
4	6	3,8	57	11	18	0,06	3	0 7250004001 00	0 7950004001 00
5	6	4,7	57	13	20	0,06	3	0 7250005001 00	0 7950005001 00
6	6	5,6	57	13	20	0,08	3	0 7250006001 00	0 7950006001 00
8	8	7,5	63	19	25	0,10	3	0 7250008001 00	0 7950008001 00
10	10	9,5	72	22	30	0,15	3	0 7250010001 00	0 7950010001 00
12	12	11,5	83	26	36	0,15	3	0 7250012001 00	0 7950012001 00
16	16	15,5	92	32	42	0,20	3	0 7250016001 00	0 7950016001 00
20	20	19,5	104	38	52	0,25	3	0 7250020001 00	0 7950020001 00
25	25	24,5	120	45	62	0,30	4	0 7250025001 00	0 7950025001 00

D VHM-Schafffräser
Speedcut-Aluminium,
 extra lang XL, freigestellt,
 Dreischneider, ungleiche
 Drallsteigung

Einsatzbereich:
 VHM-Hochleistungsfräser besonders geeignet zur Bearbeitung von Aluminium-Werkstoffen (sowohl für Guss- als auch Knetlegierungen). Kernanstieg für höchste Stabilität, bester Spanabfluss durch optimiertes Fertigungs-Schleifverfahren, dadurch extrem glatte Oberfläche. Höchstes Zerspanvolumen und beste Oberflächengüte durch einzigartige Schneidengeometrie.

E Solid carbide end mill
Speedcut-Aluminium,
 extra long series XL, neck,
 three flutes, different spiral
 angles

Range of application:
 Solid carbide high performance end mill especially suitable for aluminium. Center web for highest stability, excellent chip breakage and chip transportation due to optimized manufacturing-grinding method, that is why extremely smooth surface. Highest cutting volume and superior surface quality due to unique cutting edge geometry.

I Frese frontali MDI
Speedcut-Alluminio,
 serie extra lunga XL, libero,
 3 taglienti, angolo elica
 disuguale

Impiego:
 Fresa frontale MDI ad alto rendimento particolarmente adatta per alluminio. Nocciolo crescente per una maggiore stabilità, eccellente rottura ed evacuazione del truciolo grazie al processo di rettifica ottimizzato che rende la superficie dell'utensile estremamente liscia. Volumi asportati elevati ed eccellente qualità della superficie ottenuta grazie alla unicità della geometria dei taglienti.

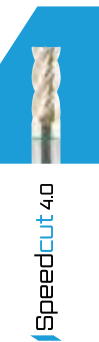
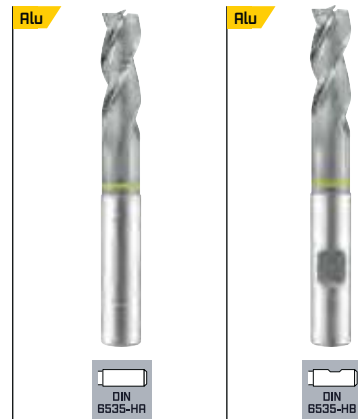
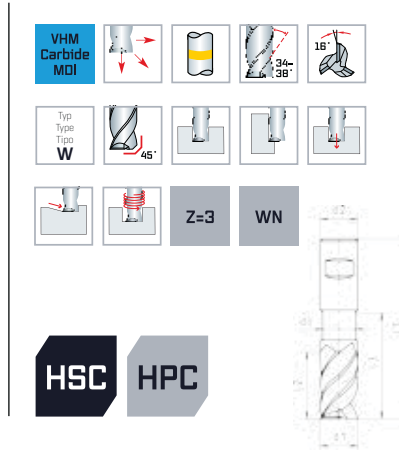

d1 _{h10} mm	d2 _{h6} mm	d3 mm	l1 mm	l2 mm	l3 mm		Z	Code 7220 Art.-Nr.	Code 7920 Art.-Nr.
3	6	2,8	60	8	18	0,05	3	0 7220003001 00	0 7920003001 00
4	6	3,8	60	11	21	0,06	3	0 7220004001 00	0 7920004001 00
5	6	4,7	62	13	26	0,06	3	0 7220005001 00	0 7920005001 00
6	6	5,6	62	13	26	0,08	3	0 7220006001 00	0 7920006001 00
8	8	7,5	70	19	34	0,10	3	0 7220008001 00	0 7920008001 00
10	10	9,5	80	22	40	0,15	3	0 7220010001 00	0 7920010001 00
12	12	11,5	95	26	50	0,15	3	0 7220012001 00	0 7920012001 00
16	16	15,5	105	32	57	0,20	3	0 7220016001 00	0 7920016001 00
20	20	19,5	124	38	71	0,25	3	0 7220020001 00	0 7920020001 00

D VHM-Schaftfräser Speedcut-Aluminium, extra lang XXL, freigestellt, Dreischneider, ungleiche Drallsteigung

E Solid carbide end mill Speedcut-Aluminium, extra long series XXL, neck, three flutes, different spiral angles

I Frese frontali MDI Speedcut-Alluminio, serie extra lunga XXL, libero, 3 taglienti, angolo elica disuguale

Einsatzbereich:

VHM-Hochleistungsfräser besonders geeignet zur Bearbeitung von Aluminium-Werkstoffen (sowohl für Guss- als auch Knetlegierungen). Kernantrieb für höchste Stabilität, bester Spanabfluss durch optimiertes Fertigungs-Schleifverfahren, dadurch extrem glatte Oberfläche. Höchstes Zerspanvolumen und beste Oberflächengüte durch einzigartige Schneidengeometrie.

Range of application:

Solid carbide high performance end mill especially suitable for aluminium. Center web for highest stability, excellent chip breakage and chip transportation due to optimized manufacturing-grinding method, that is why extremely smooth surface. Highest cutting volume and superior surface quality due to unique cutting edge geometry.

Impiego:

Fresa frontale MDI ad alto rendimento particolarmente adatta per alluminio. Nocciolo crescente per una maggiore stabilità, eccellente rottura ed evacuazione del truciolo grazie al processo di rettifica ottimizzato che rende la superficie dell'utensile estremamente liscia. Volumi asportati elevati ed eccellente qualità della superficie ottenuta grazie alla unicità della geometria dei taglienti.

Speedcut

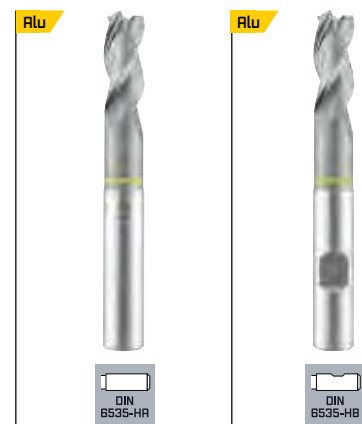
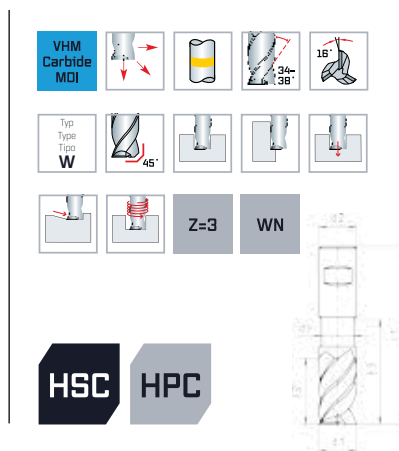

d1 _{h10} mm	d2 _{h6} mm	d3 mm	l1 mm	l2 mm	l3 mm		Z	Code 7290 Art.-Nr.	Code 7990 Art.-Nr.
3	6	2,8	60	8	20	0,05	3	0 7290003001 00	0 7990003001 00
4	6	3,8	65	11	26	0,06	3	0 7290004001 00	0 7990004001 00
5	6	4,7	76	13	39	0,06	3	0 7290005001 00	0 7990005001 00
6	6	5,6	76	13	39	0,08	3	0 7290006001 00	0 7990006001 00
8	8	7,5	100	19	62	0,10	3	0 7290008001 00	0 7990008001 00
10	10	9,5	100	22	58	0,15	3	0 7290010001 00	0 7990010001 00
12	12	11,5	120	26	73	0,15	3	0 7290012001 00	0 7990012001 00
16	16	15,5	150	32	100	0,20	3	0 7290016001 00	0 7990016001 00
20	20	19,5	150	38	100	0,25	3	0 7290020001 00	0 7990020001 00

D VHM-Schafffräser mit Eckenradius Speedcut-Aluminium, lang, freigestellt, Dreischneider, ungleiche Drallsteigung

E Solid carbide corner radius end mill Speedcut-Aluminium, long series, neck, three flutes, different spiral angles

I Frese frontali MDI con spigolo raggato Speedcut-Alluminio, serie lunga, libero, 3 taglienti, angolo elica disuguale

Einsatzbereich:

VHM-Hochleistungsfräser besonders geeignet zur Bearbeitung von Aluminium-Werkstoffen (sowohl für Guss- als auch Knetlegierungen). Kernantrieb für höchste Stabilität, bester Spanabfluss durch optimiertes Fertigungs-Schleifverfahren, dadurch extrem glatte Oberfläche. Höchstes Zerspanvolumen und beste Oberflächengüte durch einzigartige Schneidengeometrie.

Range of application:

Solid carbide high performance end mill especially suitable for aluminium. Center web for highest stability, excellent chip breakage and chip transportation due to optimized manufacturing-grinding method, that is why extremely smooth surface. Highest cutting volume and superior surface quality due to unique cutting edge geometry.

Impiego:

Fresa frontale MDI ad alto rendimento particolarmente adatta per alluminio. Nocciolo crescente per una maggiore stabilità, eccellente rottura ed evacuazione del truciolo grazie al processo di rettifica ottimizzato che rende la superficie dell'utensile estremamente liscia. Volumi asportati elevati ed eccellente qualità della superficie ottenuta grazie alla unicità della geometria dei taglienti.

Speedcut

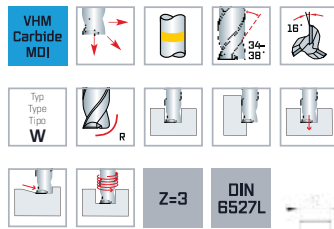

HSC HPC



d1 _{h10} mm	R	d2 _{h6} mm	d3 mm	l1 mm	l2 mm	l3 mm	Z	Code 7230 Art.-Nr.
3	0,5	6	2,8	57	8	16	3	0 7230003051 00
4	0,5	6	3,8	57	11	18	3	0 7230004051 00
5	0,5	6	4,7	57	13	20	3	0 7230005051 00
	1	6	4,7	57	13	20	3	0 7230005101 00
6	0,5	6	5,6	57	13	20	3	0 7230006051 00
	1	6	5,6	57	13	20	3	0 7230006101 00
8	0,5	8	7,5	63	19	25	3	0 7230008051 00
	1	8	7,5	63	19	25	3	0 7230008101 00
	2	8	7,5	63	19	25	3	0 7230008201 00
10	0,5	10	9,5	72	22	30	3	0 7230010051 00
	1	10	9,5	72	22	30	3	0 7230010101 00
	2	10	9,5	72	22	30	3	0 7230010201 00
12	1	12	11,5	83	26	36	3	0 7230012101 00
	2	12	11,5	83	26	36	3	0 7230012201 00
16	3	12	11,5	83	26	36	3	0 7230012301 00
	1	16	15,5	92	32	42	3	0 7230016101 00
	2	16	15,5	92	32	42	3	0 7230016201 00

Optional ohne Aufpreis auch mit Weldon-Schaft (DIN 6535-HB) lieferbar. | Also available with Weldon-shank (DIN 6535-HB) without extra charge. | Anche disponibili con attacco Weldon (DIN 6535-HB) senza prezzo aggiuntivo.

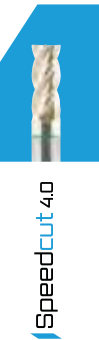

Speedcut 4.0

D VHM-Schaftfräser mit Eckenradius Speedcut-Aluminium, extra lang XL, freigestellt, Dreischneider, ungleiche Drallsteigung

Einsatzbereich:

VHM-Hochleistungsfräser besonders geeignet zur Bearbeitung von Aluminium-Werkstoffen (sowohl für Guss- als auch Knetlegierungen). Kernanstieg für höchste Stabilität, bester Spanabfluss durch optimiertes Fertigungs-Schleifverfahren, dadurch extrem glatte Oberfläche. Höchstes Zerspanvolumen und beste Oberflächengüte durch einzigartige Schneidengeometrie.

Speedcut



E Solid carbide corner radius end mill Speedcut-Aluminium, extra long series XL, neck, three flutes, different spiral angles

Range of application:

Solid carbide high performance end mill especially suitable for aluminium. Center web for highest stability, excellent chip breakage and chip transportation due to optimized manufacturing-grinding method, that is why extremely smooth surface. Highest cutting volume and superior surface quality due to unique cutting edge geometry.

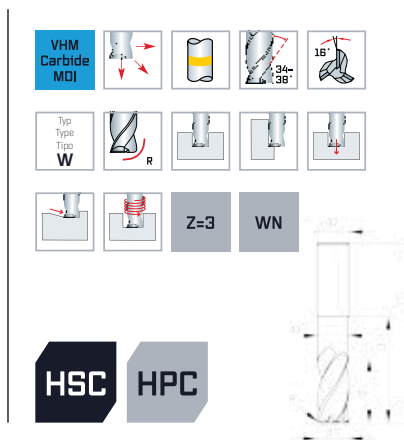

I Frese frontali MDI con spigolo raggato Speedcut-Aluminium, serie extra lunga XL, libero, 3 taglienti, angolo elica disuguale

Impiego:

Fresa frontale MDI ad alto rendimento particolarmente adatta per alluminio. Nocciolo crescente per una maggiore stabilità, eccellente rottura ed evacuazione del truciolo grazie al processo di rettifica ottimizzato che rende la superficie dell'utensile estremamente liscia. Volumi asportati elevati ed eccellente qualità della superficie ottenuta grazie alla unicità della geometria dei taglienti.



d1 h10 mm	R	d2 h6 mm	d3 mm	l1 mm	l2 mm	l3 mm	Z	Code 7090 Art.-Nr.
3	0,5	6	2,8	60	8	18	3	0 7090003051 00
4	0,5	6	3,8	60	11	21	3	0 7090004051 00
5	0,5	6	4,7	62	13	26	3	0 7090005051 00
	1	6	4,7	62	13	26	3	0 7090005101 00
6	0,5	6	5,6	62	13	26	3	0 7090006051 00
	1	6	5,6	62	13	26	3	0 7090006101 00
8	0,5	8	7,5	70	19	34	3	0 7090008051 00
	1	8	7,5	70	19	34	3	0 7090008101 00
	2	8	7,5	70	19	34	3	0 7090008201 00
10	0,5	10	9,5	80	22	40	3	0 7090010051 00
	1	10	9,5	80	22	40	3	0 7090010101 00
	2	10	9,5	80	22	40	3	0 7090010201 00
12	1	12	12	95	26	50	3	0 7090012101 00
	2	12	12	95	26	50	3	0 7090012201 00
16	1	12	12	95	26	50	3	0 7090012301 00
	1	16	16	105	32	57	3	0 7090016101 00
	2	16	16	105	32	57	3	0 7090016201 00
20	2	20	20	124	38	71	3	0 7090020201 00
	4	20	20	124	38	71	3	0 7090020401 00

Optional ohne Aufpreis auch mit Weldon-Schaft [DIN 6535-HB] lieferbar. | Also available with Weldon-shank [DIN 6535-HB] without extra charge. | Anche disponibili con attacco Weldon [DIN 6535-HB] senza prezzo aggiuntivo.

D VHM-Vollradiusfräser Speedcut-Aluminium, lang, freigestellt, Zweischneider, ungleiche Drallsteigung

Einsatzbereich:
VHM-Hochleistungsfräser besonders geeignet zur Bearbeitung von Aluminium-Werkstoffen (sowohl für Guss- als auch Knetlegierungen). Kernantrieb für höchste Stabilität, bester Spanabfluss durch optimiertes Fertigungs-Schleifverfahren, dadurch extrem glatte Oberfläche. Höchstes Zerspanvolumen und beste Oberflächengüte durch einzigartige Schneidengeometrie.

Speedcut



E Solid carbide ballnose end mill Speedcut-Aluminium, long series, neck, two flutes, different spiral angles

Range of application:
Solid carbide high performance end mill especially suitable for aluminium. Center web for highest stability, excellent chip breakage and chip transportation due to optimized manufacturing-grinding method, that is why extremely smooth surface. Highest cutting volume and superior surface quality due to unique cutting edge geometry.

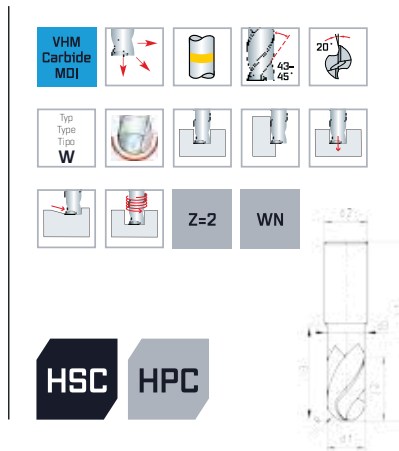

I Frese cilindrica raggiata in metallo duro Speedcut-Aluminium, serie lunga, libero, 2 taglienti, angolo elica disuguale

Impiego:
Fresa frontale MDI ad alto rendimento particolarmente adatta per alluminio. Nocciolo crescente per una maggiore stabilità, eccellente rottura ed evacuazione del truciolo grazie al processo di rettifica ottimizzato che rende la superficie dell'utensile estremamente liscia. Volumi asportati elevati ed eccellente qualità della superficie ottenuta grazie alla unicità della geometria dei taglienti.

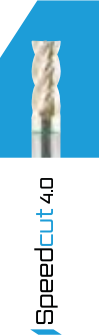

d1 _{h10} mm	d2 _{h6} mm	d3 mm	l1 mm	l2 mm	l3 mm	Z	Code 7240 Art.-Nr.
3	6	2,9	57	5	16	2	0 7240003001 00
4	6	3,9	57	6	18	2	0 7240004001 00
5	6	4,9	57	8	20	2	0 7240005001 00
6	6	5,9	57	10	20	2	0 7240006001 00
8	8	7,8	63	12	25	2	0 7240008001 00
10	10	9,8	72	15	30	2	0 7240010001 00
12	12	11,8	83	18	36	2	0 7240012001 00
16	16	15,8	92	24	42	2	0 7240016001 00
20	20	19,5	104	30	52	2	0 7240020001 00

Optional ohne Aufpreis auch mit Weldon-Schaft [DIN 6535-HB] lieferbar. | Also available with Weldon-shank [DIN 6535-HB] without extra charge. | Anche disponibili con attacco Weldon [DIN 6535-HB] senza prezzo aggiuntivo.

D VHM-Vollradiusfräser Speedcut-Aluminium, extra lang XXL, freigestellt, Zweischneider, ungleiche Drallsteigung

Einsatzbereich:

VHM-Hochleistungsfräser besonders geeignet zur Bearbeitung von Aluminium-Werkstoffen (sowohl für Guss- als auch Knetlegierungen). Kernanstieg für höchste Stabilität, bester Spanabfluss durch optimiertes Fertigungs-Schleifverfahren, dadurch extrem glatte Oberfläche. Höchstes Zerspanvolumen und beste Oberflächengüte durch einzigartige Schneidengeometrie.

Speedcut



E Solid carbide ballnose end mill Speedcut-Aluminium, extra long series XXL, neck, two flutes, different spiral angles

Range of application:

Solid carbide high performance end mill especially suitable for aluminium. Center web for highest stability, excellent chip breakage and chip transportation due to optimized manufacturing-grinding method, that is why extremely smooth surface. Highest cutting volume and superior surface quality due to unique cutting edge geometry.

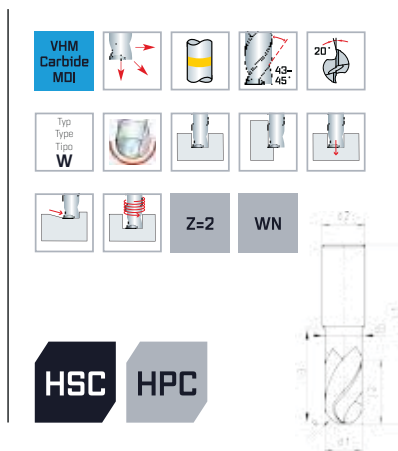

I Frese cilindrica raggiata in metallo duro Speedcut-Aluminium, serie extra lunga XXL, libero, 2 taglienti, angolo elica disuguale

Impiego:

Fresa frontale MDI ad alto rendimento particolarmente adatta per alluminio. Nocciolo crescente per una maggiore stabilità, eccellente rottura ed evacuazione del truciolo grazie al processo di rettifica ottimizzato che rende la superficie dell'utensile estremamente liscia. Volumi asportati elevati ed eccellente qualità della superficie ottenuta grazie alla unicità della geometria dei taglienti.



d1 _{h10} mm	d2 _{h6} mm	d3 mm	l1 mm	l2 mm	l3 mm	Z	Code 7260 Art.-Nr.
3	6	2,9	60	5	20	2	0 7260003001 00
4	6	3,9	65	6	26	2	0 7260004001 00
5	6	4,9	76	8	39	2	0 7260005001 00
6	6	5,9	76	10	39	2	0 7260006001 00
8	8	7,8	100	12	62	2	0 7260008001 00
10	10	9,8	100	15	58	2	0 7260010001 00
12	12	11,8	120	18	73	2	0 7260012001 00
16	16	15,8	150	24	100	2	0 7260016001 00
20	20	19,5	150	30	98	2	0 7260020001 00

Optional ohne Aufpreis auch mit Weldon-Schaft [DIN 6535-HB] lieferbar. | Also available with Weldon-shank [DIN 6535-HB] without extra charge. | Anche disponibili con attacco Weldon [DIN 6535-HB] senza prezzo aggiuntivo.

**D VHM-Schrupfräser 35°
Speedcut-Aluminium,**
lang, freigestellt,
Dreischneider, ungleiche
Drallsteigung

**E Solid carbide roughing
end mill 35°
Speedcut-Aluminium,**
long series, neck, three
flutes, different spiral angles

**I Frese frontali MDI a
sgrossare 35°
Speedcut-Alluminio,**
serie lunga, libero, 3 taglienti,
angolo elica disuguale

Einsatzbereich:

VHM-Hochleistungs-Schrupfräser, besonders geeignet zur Bearbeitung von Aluminium-Werkstoffen (sowohl für Guss- als auch Knetlegierungen). Extrem glatte Oberfläche verhindert die Bildung von Aufbauschneiden.

Range of application:

Solid carbide high performance roughing cutter especially suitable for aluminium. Extremely smooth surface prevents built-up edges.

Impiego:

Fresa a sgrossare MDI ad alto rendimento particolarmente adatta per alluminio. Superficie extra liscia previene il tagliante di riporto.

Speedcut

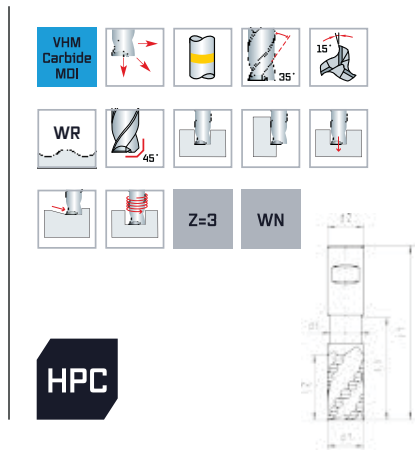

d1 _{h10} mm	d2 _{h6} mm	d3 mm	l1 mm	l2 mm	l3 mm	45°	Z	Code 7015 Art.-Nr.	Code 7115 Art.-Nr.
6	6	5,6	57	10	20	0,35	3	0 7015006001 00	0 7115006001 00
8	8	7,5	63	13	25	0,35	3	0 7015008001 00	0 7115008001 00
10	10	9,5	72	16	30	0,45	3	0 7015010001 00	0 7115010001 00
12	12	11,5	83	19	36	0,45	3	0 7015012001 00	0 7115012001 00
16	16	15,5	92	25	42	0,65	3	0 7015016001 00	0 7115016001 00
20	20	19,5	104	31	52	0,65	3	0 7015020001 00	0 7115020001 00

D VHM-Schrupfräser 35° Speedcut-Aluminium, extra lang XL, freigestellt, Dreischneider, ungleiche Drallsteigung

Einsatzbereich:
VHM-Hochleistungs-Schrupfräser, besonders geeignet zur Bearbeitung von Aluminium-Werkstoffen [sowohl für Guss- als auch Knetlegierungen]. Extrem glatte Oberfläche verhindert die Bildung von Aufbauschneiden.

E Solid carbide roughing end mill 35° Speedcut-Aluminium, extra long series XL, neck, three flutes, different spiral angles

Range of application:
Solid carbide high performance roughing cutter especially suitable for aluminium. Extremely smooth surface prevents built-up edges.

I Frese frontali MDI a sgrossare 35° Speedcut-Alluminio, serie extra lunga XL, libero, 3 taglienti, angolo elica disuguale

Impiego:
Fresa a sgrossare MDI ad alto rendimento particolarmente adatta per alluminio. Superficie extra liscia previene il tagliante di riporto.

Speedcut

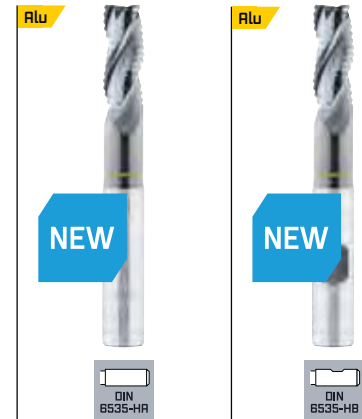
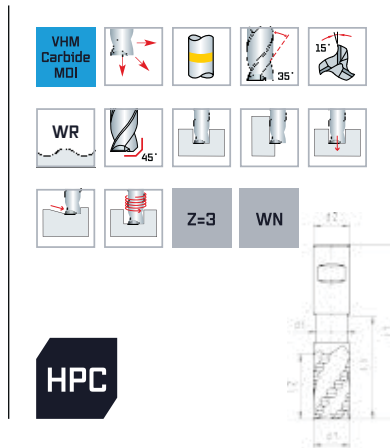

d1 _{h10} mm	d2 _{h6} mm	d3 mm	l1 mm	l2 mm	l3 mm		Z	Code 7055 Art.-Nr.	Code 7155 Art.-Nr.
6	6	5,6	62	13	26	0,35	3	0 7055006001 00	0 7155006001 00
8	8	7,5	70	19	34	0,35	3	0 7055008001 00	0 7155008001 00
10	10	9,5	80	22	40	0,45	3	0 7055010001 00	0 7155010001 00
12	12	12	95	26	50	0,45	3	0 7055012001 00	0 7155012001 00
16	16	16	105	32	57	0,65	3	0 7055016001 00	0 7155016001 00
20	20	20	124	38	71	0,65	3	0 7055020001 00	0 7155020001 00

D VHM-Schaftfräser ecoSpeedcut-Universal, kurz, Vierschneider, ungleiche Drallsteigung

E Solid carbide end mill ecoSpeedcut-Universal, short series, four flutes, different spiral angles

I Fresa in metallo duro ecoSpeedcut-Universali, serie corta, 4 taglienti, angolo dell'elica variabile

Einsatzbereich:

VHM-Hochleistungsfräser für universellen Einsatz: kurze, stabile Ausführung und weicher Schnitt [10 Grad]. Besonders geeignet zur Schruppbearbeitung, Schlichtbearbeitung und Nutbearbeitung in CNC Fräsbearbeitungszentren, in kombinierten Dreh- und Fräszentren sowie auf Drehautomaten. Ungleiche Drallsteigung bewirkt ruhigen, vibrationsarmen Lauf und sehr gute Oberflächengüte. Hohe Zerspanungsleistung.

Range of application:

High performance carbide end mill for universal applications: short, stable design and soft cut [10 degrees]. Especially suitable for roughing, finishing and groove machining in CNC milling centers, in combined turning and milling centers and automatic lathes. Different spiral angles effect smooth, vibrationless running and excellent surface. High cutting performance.

Impiego:

MDI Fresa ad alto rendimento per applicazioni universali: versione corta e stabile e taglio dolce [angolo di spoglia 10°]. Particolarmente indicate per sgrossatura, finitura e lavorazioni di cave con centri di fresatura CNC, con centri combinati di fresatura e tornitura e torni automatici. Angolo dell'elica variabile che garantisce lavorazioni senza vibrazioni ed eccellenti superfici. Elevato asportazione truciolo.

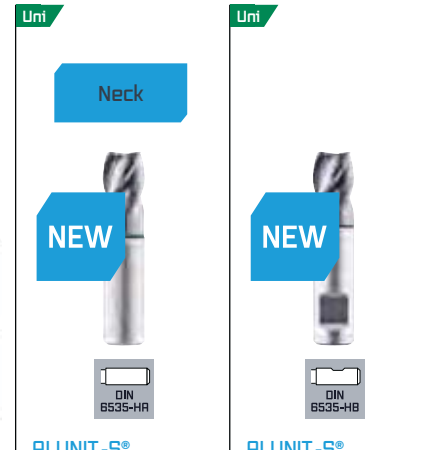
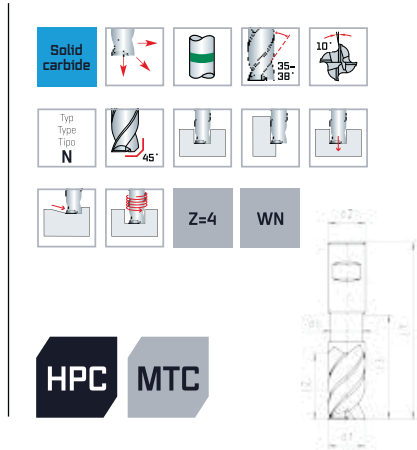
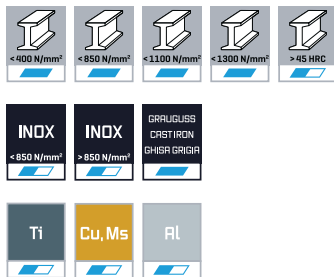

d1 _{h10} mm	d2 _{h6} mm	d3* mm	l1 mm	l2 mm	l3* mm		Z	Code 7627 Art.-Nr.		Code 7127 Art.-Nr.	
4	6	3,8	40	6	10	0,20	4	0 7627004001 00	10	0 7127004001 00	10
6	6	5,6	40	8	12	0,20	4	0 7627006001 00	10	0 7127006001 00	10
8	8	7,5	50	12	16	0,25	4	0 7627008001 00	10	0 7127008001 00	10
10	10	9,5	50	13	20	0,25	4	0 7627010001 00	6	0 7127010001 00	6
12	12	11,5	50	15	24	0,25	4	0 7627012001 00	6	0 7127012001 00	6

*Nur für Code 7627. | Only for Code 7627. | Solo per il Codice 7627.

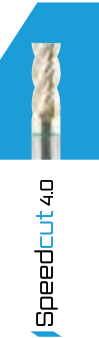

D **STC-Schaftfräser**
Speedtwister-Universal,
 lang, freigestellt,
 Fünfschneider, ungleiche
 Drallsteigung, **3xD**

Einsatzbereich:
 Trochoidaler Hochleistungsfräser für universellen Einsatz. Für statische und dynamische Bearbeitungen. Sehr hohe Laufruhe und perfekte Spankontrolle durch modernste Werkzeuggeometrien setzt neue Maßstäbe in der Zerspanungsleistung.

Speedtwister

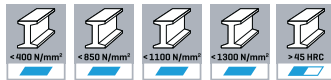

E **STC end mill**
Speedtwister-Universal,
 long series, neck, five flutes,
 different spiral angles, **3xD**

Range of application:
 Trochoidal high performance carbide end mill for universal applications. For static and dynamic strategies. Very smooth operation and perfect chip control through modern tool geometry sets new standards in chip removal.

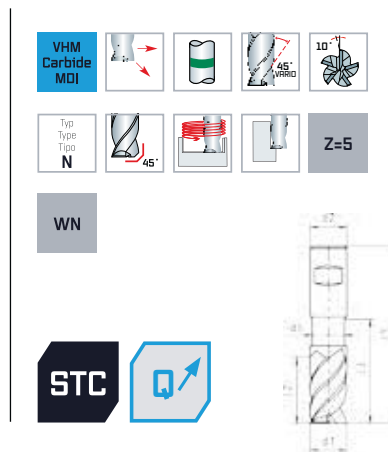

I **Fresa frontale STC**
Speedtwister-Universali,
 serie lunga, libero, 5 taglianti,
 angolo elica disuguale, **3xD**

Impiego:
 Fresa trocoidale ad alto rendimento per applicazioni universali. Idonea per fresatura statiche e dinamiche. Elevata silenziosità e un perfetto controllo del truciolo dalla più moderna geometria dell'utensile stabilisce nuove standard nell'trasporto truciolo.

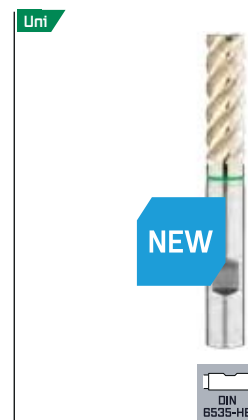

TWINDUR

d1 _{r8} mm	d2 _{h6} mm	d3 mm	l1 mm	l2 mm	l3 mm		Z	Code 6117 Art.-Nr.
3	6	2,8	54	10	14	0,05	5	0 6117003001 00
4	6	3,8	57	13	18	0,05	5	0 6117004001 00
5	6	4,8	59	16	22	0,05	5	0 6117005001 00
6	6	5,8	64	20	28	0,05	5	0 6117006001 00
8	8	7,8	72	26	34	0,05	5	0 6117008001 00
10	10	9,8	79	32	40	0,05	5	0 6117010001 00
12	12	11,8	92	38	46	0,05	5	0 6117012001 00
16	16	15,8	106	50	58	0,05	5	0 6117016001 00
20	20	19,8	125	62	70	0,05	5	0 6117020001 00

Spanbrecher 2 Stk. / Chip breaker 2 pcs. / Rompitrucioli 2 pz.

D **STC-Schaftfräser**
Speedtwister-Universal,
 extra lang XL, Fünfschneider,
 ungleiche Drallsteigung, **5xD**

Einsatzbereich:
 Trochoidaler Hochleistungsfräser für universellen Einsatz. Für statische und dynamische Bearbeitungen. Sehr hohe Laufruhe und perfekte Spankontrolle durch modernste Werkzeuggeometrien setzt neue Maßstäbe in der Zerspanungsleistung.

E **STC end mill**
Speedtwister-Universal,
 extra long series XL, five
 flutes, different spiral
 angles, **5xD**

Range of application:
 Trochoidal high performance carbide end mill for universal applications. For static and dynamic strategies. Very smooth operation and perfect chip control through modern tool geometry sets new standards in chip removal.

I **Fresa frontale STC**
Speedtwister-Universali,
 serie extra lunga XL,
 5 taglienti, angolo elica
 disuguale, **5xD**

Impiego:
 Fresa trocoidale ad alto rendimento per applicazioni universali. Idonea per fresatura statiche e dinamiche. Elevata silenziosità e un perfetto controllo del truciolo dalla più moderna geometria dell'utensile stabilisce nuove standard nell'trasporto truciolo.

Speedtwister

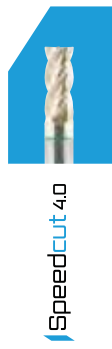
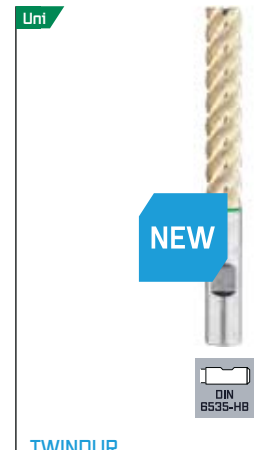
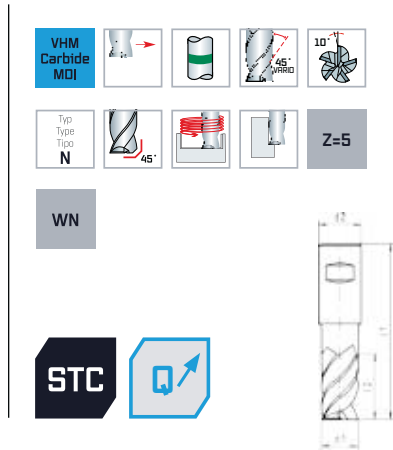
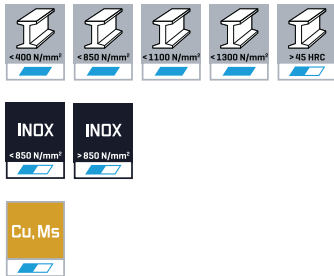

d1 mm	d2 mm	l1 mm	l2 mm		Z	Code 6137 Art.-Nr.
6	6	70	32	0,05	5	0 6137006001 00
8	8	80	42	0,05	5	0 6137008001 00
10	10	99	52	0,05	5	0 6137010001 00
12	12	115	62	0,05	5	0 6137012001 00
16	16	140	82	0,05	5	0 6137016001 00

Spanbrecher 3 Stk. / Chip breaker 3 pcs. / Rompitruccioli 3 pz.

D **STC-Schaftfräser**
Speedtwister-Inox,
 lang, freigestellt,
 Fünfschneider, ungleiche
 Drallsteigung, **3xD**

Einsatzbereich:
 Trochoidaler Hochleistungsfräser für austenitische rostfreie Stähle. Für statische und dynamische Bearbeitungen. Sehr hohe Laufruhe und perfekte Spankontrolle durch modernste Werkzeuggeometrien setzt neue Maßstäbe in der Zerspanungsleistung.

Speedtwister

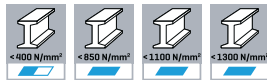

E **STC end mill**
Speedtwister-Inox,
 long series, neck, five flutes,
 different spiral angles, **3xD**

Range of application:
 Trochoidal high performance carbide end mill for austenitic stainless steels. For static and dynamic strategies. Very smooth operation and perfect chip control through modern tool geometry sets new standards in chip removal.

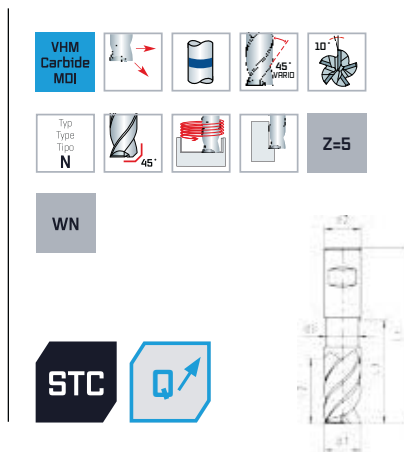

I **Fresa frontale STC**
Speedtwister-Inox,
 serie lunga, libero, 5 taglienti,
 angolo elica disuguale, **3xD**

Impiego:
 Fresa trocoidale ad alto rendimento per la lavorazione di acciai austenitici inossidabili. Idonea per fresatura statiche e dinamiche. Elevata silenziosità e un perfetto controllo del truciolo dalla più moderna geometria dell'utensile stabilisce nuove standard nell'trasporto truciolo.



d1 f8 mm	d2 h6 mm	d3 mm	l1 mm	l2 mm	l3 mm		Z	Code 6107 Art.-Nr.
3	6	2,8	54	10	14	0,05	5	0 6107003001 00
4	6	3,8	57	13	18	0,05	5	0 6107004001 00
5	6	4,8	59	16	22	0,05	5	0 6107005001 00
6	6	5,8	64	20	28	0,05	5	0 6107006001 00
8	8	7,8	72	26	34	0,05	5	0 6107008001 00
10	10	9,8	79	32	40	0,05	5	0 6107010001 00
12	12	11,8	92	38	46	0,05	5	0 6107012001 00
16	16	15,8	106	50	58	0,05	5	0 6107016001 00
20	20	19,8	125	62	70	0,05	5	0 6107020001 00

Spanbrecher 2 Stk. / Chip breaker 2 pcs. / Rompitruccioli 2 pz.

D **STC-Schaftfräser**
Speedtwister-Inox,
extra lang XL, Fünfschneider,
ungleiche Drallsteigung, **5xD**

Einsatzbereich:

Trochoidaler Hochleistungsfräser für austenitische rostfreie Stähle. Für statische und dynamische Bearbeitungen. Sehr hohe Laufruhe und perfekte Spankontrolle durch modernste Werkzeuggeometrien setzt neue Maßstäbe in der Zerspanungsleistung.

Speedtwister

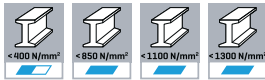

E **STC end mill**
Speedtwister-Inox,
extra long series XL, five
flutes, different spiral
angles, **5xD**

Range of application:

Trochoidal high performance carbide end mill for austenitic stainless steels. For static and dynamic strategies. Very smooth operation and perfect chip control through modern tool geometry sets new standards in chip removal.

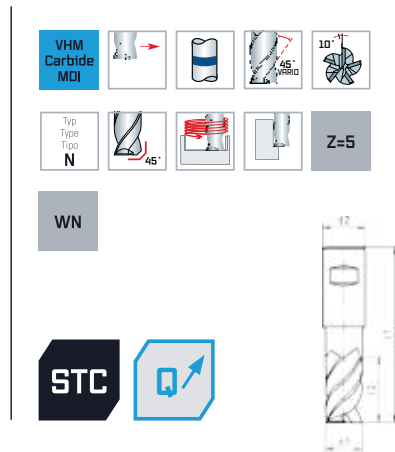

I **Fresa frontale STC**
Speedtwister-Inox,
serie extra lunga XL,
5 taglienti, angolo elica
disuguale, **5xD**

Impiego:

Fresa trocoidale ad alto rendimento per la lavorazione di acciai austenitici inossidabili. Idonea per fresatura statiche e dinamiche. Elevata silenziosità e un perfetto controllo del truciolo dalla più moderna geometria dell'utensile stabilisce nuove standard nell'trasporto truciolo.

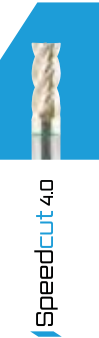

d1 _{f8} mm	d2 _{h6} mm	l1 mm	l2 mm		Z	Code 6197 Art.-Nr.
6	6	70	32	0,05	5	0 6197006001 00
8	8	80	42	0,05	5	0 6197008001 00
10	10	99	52	0,05	5	0 6197010001 00
12	12	115	62	0,05	5	0 6197012001 00
16	16	140	82	0,05	5	0 6197016001 00

Spanbrecher 3 Stk. / Chip breaker 3 pcs. / Rompitruccioli 3 pz.

D HSC Torusfräser
kurz, Vierschneider

Einsatzbereich:
HSC Hochleistungswerkzeuge für den Werkzeug- und Formenbau. Für hochlegierte und gehärtete Materialien.



E HSC Torus end mill,
short series, four flutes

Range of application:
HSC high-performance tools for tool and mold making. For high-alloy and hardened materials.



I HSC Fresa toroidale,
serie corta, 4 taglienti

Impiego:
HSC utensili ad alto rendimento per produzione utensili e stampi.

RS=±0,005 mm

NEW



KUPRADOUR

d1 e8 mm	d2 h5 mm	l1 mm	l2 mm	l3 mm	R mm	Z	Code 7110 Art.-Nr.
2	4	40	3	8	0,2	3	0 7110002021 00
2	4	40	3	8	0,3	3	0 7110002031 00
3	6	57	4	12	0,3	4	0 7110003031 00
3	6	57	4	12	0,5	4	0 7110003051 00
4	6	57	5	15	0,5	4	0 7110004051 00
4	6	57	5	15	1	4	0 7110004101 00
5	6	57	6	18	0,5	4	0 7110005051 00
5	6	57	6	18	1	4	0 7110005101 00
5	6	57	6	18	1,5	4	0 7110005151 00
6	6	57	7	21	0,5	4	0 7110006051 00
6	6	57	7	21	1	4	0 7110006101 00
6	6	57	7	21	1,5	4	0 7110006151 00
8	8	63	9	27	0,5	4	0 7110008051 00
8	8	63	9	27	1	4	0 7110008101 00
8	8	63	9	27	1,5	4	0 7110008151 00
8	8	63	9	27	2	4	0 7110008201 00
10	10	72	11	32	0,5	4	0 7110010051 00
10	10	72	11	32	1	4	0 7110010101 00
10	10	72	11	32	1,5	4	0 7110010151 00
10	10	72	11	32	2	4	0 7110010201 00
10	10	72	11	32	2,5	4	0 7110010251 00
12	12	83	12	38	0,5	4	0 7110012051 00
12	12	83	12	38	1	4	0 7110012101 00
12	12	83	12	38	1,5	4	0 7110012151 00
12	12	83	12	38	2	4	0 7110012201 00
12	12	83	12	38	3	4	0 7110012301 00
16	16	92	16	44	1	4	0 7110016101 00
16	16	92	16	44	2	4	0 7110016201 00
16	16	92	16	44	4	4	0 7110016401 00

D HSC Torusfräser
lang, Vierschneider,

E HSC Torus end mill,
long series, four flutes,

I HSC Fresa toroidale,
serie lunga, 4 taglienti,

Einsatzbereich:
HSC Hochleistungswerkzeuge für den Werkzeug- und Formenbau. Für hochlegierte und gehärtete Materialien.

Range of application:
HSC high-performance tools for tool and mold making. For high-alloy and hardened materials.

Impiego:
HSC utensili ad alto rendimento per produzione utensili e stampi.

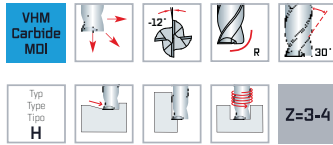
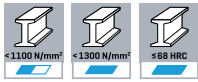

KUPRADOUR

d1 _{e8} mm	d2 _{h5} mm	l1 mm	l2 mm	l3 mm	R mm	Z	Code 7210 Art.-Nr.
2	4	59	3	12	0,2	3	0 7210002021 00
3	6	69	4	18	0,3	4	0 7210003031 00
3	6	69	4	18	0,5	4	0 7210003051 00
4	6	69	5	24	0,5	4	0 7210004051 00
4	6	69	5	24	1	4	0 7210004101 00
5	6	69	6	30	0,5	4	0 7210005051 00
5	6	69	6	30	1	4	0 7210005101 00
6	6	80	7	44	0,5	4	0 7210006051 00
6	6	80	7	44	1	4	0 7210006101 00
6	6	80	7	44	1,5	4	0 7210006151 00
8	8	80	7	44	0,5	4	0 7210008051 00
8	8	100	9	54	1	4	0 7210008101 00
8	8	100	9	54	1,5	4	0 7210008151 00
8	8	100	9	54	2	4	0 7210008201 00
10	10	100	11	60	0,5	4	0 7210010051 00
10	10	100	11	60	1	4	0 7210010101 00
10	10	100	11	60	1,5	4	0 7210010151 00
10	10	100	11	60	2	4	0 7210010201 00
10	10	100	11	60	2,5	4	0 7210010251 00
12	12	120	12	75	0,5	4	0 7210012051 00
12	12	120	12	75	1	4	0 7210012101 00
12	12	120	12	75	1,5	4	0 7210012151 00
12	12	120	12	75	2	4	0 7210012201 00
12	12	120	12	75	3	4	0 7210012301 00
16	16	140	16	92	1	4	0 7210016101 00
16	16	150	16	92	2	4	0 7210016201 00
16	16	140	16	92	4	4	0 7210016401 00

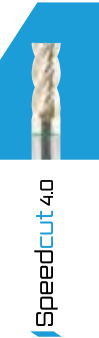

D HSC Vollradiusfräser
kurz, Zweischneider,

Einsatzbereich:
HSC Hochleistungswerkzeuge für den Werkzeug- und Formenbau. Für hochlegierte und gehärtete Materialien.

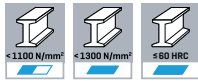

E HSC ballnose end mill,
short series, two flutes,

Range of application:
HSC high-performance tools for tool and mold making. For high-alloy and hardened materials.

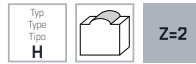
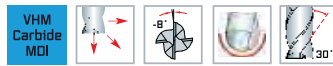

I Frese cilindrica raggiata in metallo duro,
serie corta, 2 taglianti,

Impiego:
HSC utensili ad alto rendimento per produzione utensili e stampi.

RS=±0,005 mm



KUPRADUR

d1 _{e8} mm	d2 _{h5} mm	l1 mm	l2 mm	l3 mm	R mm	Z	Code 7060 Art.-Nr.
3	6	57	4	9	1,5	2	0 7060003001 00
4	6	57	5	12	2	2	0 7060004001 00
5	6	57	6	15	2,5	2	0 7060005001 00
6	6	57	7	20	3	2	0 7060006001 00
8	8	63	9	26	4	2	0 7060008001 00
10	10	72	11	31	5	2	0 7060010001 00
12	12	83	12	37	6	2	0 7060012001 00
16	16	92	16	43	8	2	0 7060016001 00

D HSC Vollradiusfräser
lang, Zweischneider,

Einsatzbereich:

HSC Hochleistungswerkzeuge für den Werkzeug- und Formenbau. Für hochlegierte und gehärtete Materialien.

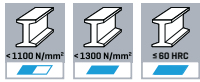

E HSC ballnose end mill,
long series, two flutes,

Range of application:

HSC high-performance tools for tool and mold making. For high-alloy and hardened materials.

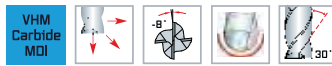

I Frese cilindrica raggiata in metallo duro,
serie lunga, 2 taglianti,

Impiego:

HSC utensili ad alto rendimento per produzione utensili e stampi.

RS=±0,005 mm

NEW



KUPRADUR

d1 _{e8} mm	d2 _{h5} mm	l1 mm	l2 mm	l3 mm	R mm	Z	Code 7160 Art.-Nr.
3	6	75	4	9	1,5	2	0 7160003001 00
4	6	75	5	12	2	2	0 7160004001 00
5	6	80	6	15	2,5	2	0 7160005001 00
6	6	80	7	20	3	2	0 7160006001 00
8	8	90	9	26	4	2	0 7160008001 00
10	10	100	11	31	5	2	0 7160010001 00
12	12	120	12	37	6	2	0 7160012001 00

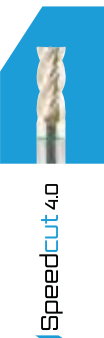

D HSC Vollradiusfräser
kurz & lang, Vierschneider

Einsatzbereich:
HSC Hochleistungswerkzeuge für den Werkzeug- und Formenbau. Für hochlegierte und gehärtete Materialien.



E HSC ballnose end mill,
short & long series,
four flutes

Range of application:
HSC high-performance tools for tool and mold making. For high-alloy and hardened materials.

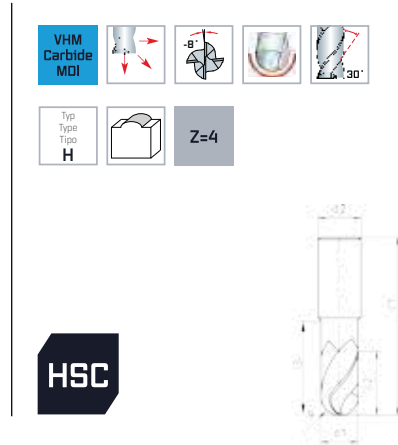

I Frese cilindrica raggiata
in metallo duro,
serie corta & lunga, 4 taglienti,

Impiego:
HSC utensili ad alto rendimento per produzione utensili e stampi.



KUPRADOR

d1 _{e8} mm	d2 _{h5} mm	l1 mm	l2 mm	l3 mm	R mm	Z	Code 7030 Art.-Nr.
4	6	60	5	12	2	4	0 7030004001 00
4	6	60	5	20	2	4	0 7030004051 00
6	6	60	10	20	3	4	0 7030006001 00
6	6	80	10	30	3	4	0 7030006051 00
8	8	75	12	26	4	4	0 7030008001 00
8	8	100	12	40	4	4	0 7030008101 00
10	10	75	16	28	5	4	0 7030010001 00
10	10	100	16	40	5	4	0 7030010101 00
12	12	100	16	30	6	4	0 7030012001 00
16	16	100	18	32	8	4	0 7030016001 00

D HSC
Konturschruppfräser

Einsatzbereich:

HSC Hochleistungswerkzeuge für den Werkzeug- und Formenbau. Für hochlegierte und gehärtete Materialien.



E HSC
Contour roughing mill

Range of application:

HSC high-performance tools for tool and mold making. For high-alloy and hardened materials.

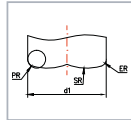
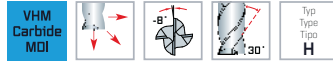

I Frese a sgrossare di contornatura

Impiego:

HSC utensili ad alto rendimento per produzione utensili e stampi.



KUPRADOUR

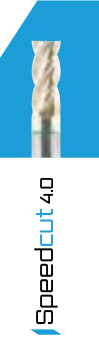

d1 _{e8} mm	d2 _{h5} mm	l1 mm	l2 mm	l3 mm	ER mm	SR mm	PR mm	Z	Code 7010 Art.-Nr.
4	6	60	4	20	0,28	3,5	0,36	2	0 7010004001 00
4	6	80	4	12	0,28	3,5	0,36	2	0 7010004011 00
6	6	60	6	25	0,42	5,0	0,55	3	0 7010006001 00
6	6	100	6	60	0,42	5,0	0,55	3	0 7010006011 00
6	6	85	6	20	0,42	5,0	0,55	2	0 7010006021 00
6	6	120	6	15	0,42	5,0	0,55	3	0 7010006031 00
8	8	65	8	30	0,56	7,0	0,72	3	0 7010008001 00
8	8	100	8	60	0,56	7,0	0,72	3	0 7010008011 00
8	8	120	8	15	0,56	7,0	0,72	3	0 7010008101 00
8	8	100	8	20	0,56	7,0	0,72	2	0 7010008201 00
10	10	75	8	40	0,7	8,0	0,92	3	0 7010010001 00
10	10	100	8	40	0,7	8,0	0,92	3	0 7010010011 00
10	10	75	8	40	1,1	8,0	1,25	3	0 7010010021 00
12	12	80	8	40	1,1	8,5	1,35	3	0 7010012001 00
12	12	125	8	50	0,84	8,5	1,15	3	0 7010012011 00
16	16	100	12	45	1,9	12,0	2,12	3	0 7010016001 00

ER = Eckenradius / corner radius / spigolo raggiato SR = Stirnradius / face radius / raggio frontale PR = Programmierradius / programming radius / raggio di programmazione