



VHM-Fräser

E Solid carbide milling cutters

I Frese in metallo duro integrale



VHM-Fräser
Solid carbide milling cutters
Frese in metallo duro integrale

D Übersicht
VHM-Fräser

E Overview
Solid carbide
milling cutters

I Sommario
Frese in metallo
duro integrale

D Die Schnittwerte für alle Werkzeuge entnehmen Sie bitte unserem separaten Zerspanungshandbuch.

E You will find the cutting conditions for all tools in our separate cutting manual.

I Per i parametri di lavorazione per tutti gli utensili richiedete il nostro manuale tecnico.

Schaftfräser / End mills / Frese frontali









































































Norm / Standard	WN						
Typ / Type / Tipo	N	N	W	N	N	N	N
Länge / Length / Lunghezza	kurz / short	kurz / short	kurz / short	lang / long	lang / long	kurz / short	kurz / short
Schneidenanzahl / No. of flutes / Nr. denti	2	2	2	2	2	3	3
Kopfform / Head type / Tipo di testa							
Drallwinkel / Spiral angle / Angolo elica	30°	30°	30°	30°	30°	30°	30°
Schaftform / Shank type / Forma codolo	d1=d2	d1=d2	d1=d2	d1=d2	d1=d2	d1=d2	d1=d2
Beschichtung / Coating / Rivestimento		ALUNIT*			ALUNIT*		ALUNIT*
Ø mm	1-20	1-20	1-20	3-12	3-12	1-20	1-20
Code / Codice	6015	6017	6915	6025	6027	6055	6057
Seite / Page / Pagina	160	160	161	162	162	163	163

Geignet für / Suitable for / Adatte per	N	N	W	N	N	N	N
Stähle < 400 N/mm² Steels < 400 N/mm ² Acciai < 400 N/mm ²							
Stähle < 850 N/mm² Steels < 850 N/mm ² Acciai < 850 N/mm ²							
Stähle < 1.100 N/mm² Steels < 1.100 N/mm ² Acciai < 1.100 N/mm ²							
Stähle < 1.300 N/mm² Steels < 1.300 N/mm ² Acciai < 1.300 N/mm ²							
Stähle > 45 HRC Steels > 45 HRC Acciai > 45 HRC							
INOX < 850 N/mm² Rostfreie Stähle < 850 N/mm ² Stainless steels < 850 N/mm ² Acciai inossidabili < 850 N/mm ²							
INOX > 850 N/mm² Rostfreie Stähle > 850 N/mm ² Stainless steels > 850 N/mm ² Acciai inossidabili > 850 N/mm ²							
Grauguss, Temperguss Cast iron, malleable cast iron Ghisa grigia, ghisa malleabile							
Ti Titanium and titanium alloys Titanio e leghe di Titanio							
Cu, Ms Kupfer, Messing Copper, brass Rame, ottone							
Al Aluminium Alluminio							
Kunststoffe Plastics Materie plastiche							

D **Übersicht**
VHM-Fräser

E **Overview**
Solid carbide
milling cutters

I **Sommario**
Frese in metallo
duro integrale

Schaftfräser / End mills / Frese frontali						
						
WN			DIN 6527L			
N	N	N	N	N	N	N
lang / long	lang / long	kurz / short	kurz / short	lang / long	lang / long	lang / long
3	3	4	4	4	3	4
						
30°	30°	30°	30°	30°	30°	30°
d1=d2	d1=d2	d1=d2	d1=d2	d1=d2	DIN 6535-HB	DIN 6535-HB
	ALUNIT®		ALUNIT®	ALUNIT®	ALUNIT®	ALUNIT®
3-20	3-20	1-20	1-20	3-25	2-12	2-20
6065	6067	6075	6077	6087	7657	7677
164	164	165	165	166	167	168
						
						
						
						
						
						
						
						
						

VHM-Fräser
Solid carbide milling cutters
Frese in metallo duro integrale

D Übersicht
VHM-Fräser

E Overview
Solid carbide
milling cutters

I Sommario
Frese in metallo
duro integrale

D Die Schnittwerte für alle Werkzeuge entnehmen Sie bitte unserem separaten Zerspanungshandbuch.

E You will find the cutting conditions for all tools in our separate cutting manual.

I Per i parametri di lavorazione per tutti gli utensili richiedete il nostro manuale tecnico.

Schaftfräser / End mills / Frese frontali

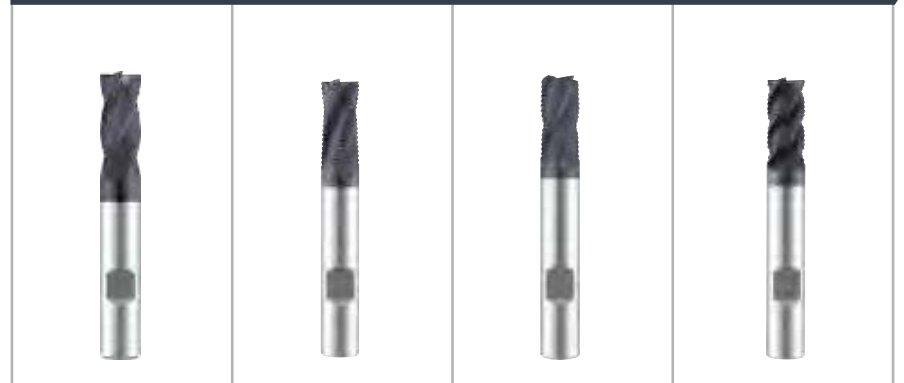





























































Norm / Standard	DIN 6527L			
Typ / Type / Tipo	N	HR	HR	HR
Länge / Length / Lunghezza	lang / long	lang / long	lang / long	lang / long
Schneidenanzahl / No. of flutes / Nr. denti	4	3-5	3-4	4-5
Kopfform / Head type / Tipo di testa				
Drallwinkel / Spiral angle / Angolo elic	30°	20°	30°	45°
Schaftform / Shank type / Forma codolo	DIN 6535-HB	DIN 6535-HB	DIN 6535-HB	DIN 6535-HB
Beschichtung / Coating / Rivestimento	ALUNIT*	ALUNIT-S*	ALUNIT*	ALUNIT-S*
Ø mm	3-20	4-20	3-20	6-20
Code / Codice	7617	7047	7027	7087
Seite / Page / Pagina	169	170	171	172

Geeignet für / Suitable for / Adatte per				
	Stähle < 400 N/mm ² Steels < 400 N/mm ² Acciai < 400 N/mm ²			
	Stähle < 850 N/mm ² Steels < 850 N/mm ² Acciai < 850 N/mm ²			
	Stähle < 1.100 N/mm ² Steels < 1.100 N/mm ² Acciai < 1.100 N/mm ²			
	Stähle < 1.300 N/mm ² Steels < 1.300 N/mm ² Acciai < 1.300 N/mm ²			
	Stähle > 45 HRC Steels > 45 HRC Acciai > 45 HRC			
	Rostfreie Stähle < 850 N/mm ² Stainless steels < 850 N/mm ² Acciai inossidabili < 850 N/mm ²			
	Rostfreie Stähle > 850 N/mm ² Stainless steels > 850 N/mm ² Acciai inossidabili > 850 N/mm ²			
	Grauguss, Temperguss Cast iron, malleable cast iron Ghisa grigia, ghisa malleabile			
	Titan- und Titanlegierung Titanium and titanium alloys Titanio e leghe di Titanio			
	Kupfer, Messing Copper, brass Rame, ottone			
	Aluminium Aluminium Alluminio			
	Kunststoffe Plastics Materie plastiche			

D **Übersicht**
VHM-Fräser

E **Overview**
Solid carbide
milling cutters

I **Sommario**
Frese in metallo
duro integrale

Schaftfräser / End mills / Frese frontali				Miniatur-Schaftfräser / Mini end mills / Frese in miniatura	
					
WN					
N	N	N	N	N	N
				kurz / short	lang / long
2	3	3	4	2	3
					
30°	30°	30°	30°	30°	30°
DIN 6535-HA	DIN 6535-HA	DIN 6535-HA	DIN 6535-HA	DIN 6535-HA	DIN 6535-HA
		ALUNIT®	ALUNIT®		ALUNIT®
1-6	1-6	1-6	1-6	0,4-3	1-3
6615	6315	6317	6517	6245	6477
173	174	174	175	176	177
					
					
					
					
					
					
					
					
					

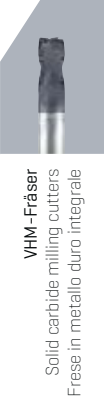

D Übersicht
VHM-Fräser











































E Overview
Solid carbide
milling cutters

I Sommario
Frese in metallo
duro integrale

D Die Schnittwerte für alle Werkzeuge entnehmen Sie bitte unserem separaten Zerspanungshandbuch.

E You will find the cutting conditions for all tools in our separate cutting manual.









































































I Per i parametri di lavorazione per tutti gli utensili richiedete il nostro manuale tecnico.

Radiusfräser / Ball nose end mills / Frese cilindriche raggate				
Norm / Standard	WN			
Typ / Type / Tipo	N	N	W	N
Länge / Length / Lunghezza	kurz / short	kurz / short	kurz / short	lang / long
Schneidenanzahl / No. of flutes / Nr. denti	2	2	2	2
Kopfform / Head type / Tipo di testa				
Drallwinkel / Spiral angle / Angolo elic	30°	30°	30°	30°
Schaftform / Shank type / Forma codolo	d1=d2	d1=d2	d1=d2	d1=d2
Beschichtung / Coating / Rivestimento		ALUNIT*		
Ø mm	1-20	1-20	1-12	3-12
Code / Codice	7525	7527	6925	7535
Seite / Page / Pagina	178	178	179	180
Geeignet für / Suitable for / Adatte per				
 Stähle < 400 N/mm² Steels < 400 N/mm ² Acciai < 400 N/mm ²				
 Stähle < 850 N/mm² Steels < 850 N/mm ² Acciai < 850 N/mm ²				
 Stähle < 1.100 N/mm² Steels < 1.100 N/mm ² Acciai < 1.100 N/mm ²				
 Stähle < 1.300 N/mm² Steels < 1.300 N/mm ² Acciai < 1.300 N/mm ²				
 Stähle > 45 HRC Steels > 45 HRC Acciai > 45 HRC				
 Rostfreie Stähle < 850 N/mm² Stainless steels < 850 N/mm ² Acciai inossidabili < 850 N/mm ²				
 Rostfreie Stähle > 850 N/mm² Stainless steels > 850 N/mm ² Acciai inossidabili > 850 N/mm ²				
 Grauguss, Temperguss Cast iron, malleable cast iron Ghisa grigia, ghisa malleabile				
 Titan- und Titanlegierung Titanium and titanium alloys Titanio e leghe di Titanio				
 Kupfer, Messing Copper, brass Rame, ottone				
 Aluminium Aluminium Alluminio				
 Kunststoffe Plastics Materie plastiche				

D **Übersicht**
VHM-Fräser

E **Overview**
Solid carbide
milling cutters

I **Sommario**
Frese in metallo
duro integrale

Radiusfräser / Ball nose end mills / Frese cilindriche raggate					Miniatur-Radiusfräser / Mini ball nose end mills / Frese in miniatura raggate	
						
WN				DIN 6527L	WN	
N	N	N	N	N	N	N
kurz / short	kurz / short	kurz / short	kurz / short	lang / long	kurz / short	lang / long
3	3	4	4	2	2	4
						
30°	30°	30°	30°	30°	30°	30°
d1=d2	d1=d2	d1=d2	d1=d2	DIN 6535-HB	DIN 6535-HA	DIN 6535-HA
	ALUNIT®		ALUNIT®	ALUNIT®		ALUNIT®
1-20	1-20	1-20	1-20	2-12	0,4-3	1-3
7555	7557	7075	7077	7517	6345	6387
181	181	182	182	183	184	185
						
						
						
						
						
						
						
						
						
						

VHM-Fräser
 Solid carbide milling cutters
 Frese in metallo duro integrale

D Übersicht
VHM-Fräser

E Overview
Solid carbide
milling cutters

I Sommario
Frese in metallo
duro integrale

D Die Schnittwerte für alle Werkzeuge entnehmen Sie bitte unserem separaten Zerspanungshandbuch.

E You will find the cutting conditions for all tools in our separate cutting manual.

I Per i parametri di lavorazione per tutti gli utensili richiedete il nostro manuale tecnico.

	Miniaturfräser / Mini end mills / Frese in miniatura		Viertelrund Profifräser / Quarter circle cutters / Frese a profilo raggiato		Multifräser Multi end mills Multi frese MDI	Entgrater / Deburring mills / Frese a smussare	
Norm / Standard			WN			DIN 6527	
Typ / Type / Tipo	H	H	N	N	N	N 60°	N 60°
Länge / Length / Lunghezza							
Schneidenanzahl / No. of flutes / Nr. denti	2	2	4	4	2	4-6	4-6
Kopfform / Head type / Tipo di testa							
Drallwinkel / Spiral angle / Angolo elic	30°	30°					
Schaftform / Shank type / Forma codolo	DIN 6535-HA	DIN 6535-HA	DIN 6535-HA	DIN 6535-HA	DIN 6535-HA	DIN 6535-HB	DIN 6535-HB
Beschichtung / Coating / Rivestimento	ALUNIT*	ALUNIT*		ALUNIT*	ALUNIT*		ALUNIT*
Ø mm	0,4-3	0,4-3	1-12	1-12	3-12	4-16	4-16
Code / Codice	6257	6297	6415	6417	6397	7725	7727
Seite / Page / Pagina	186	187	188	188	189	190	190
Geignet für / Suitable for / Adatte per							
Stähle < 400 N/mm ² Steels < 400 N/mm ² Acciai < 400 N/mm ²							
Stähle < 850 N/mm ² Steels < 850 N/mm ² Acciai < 850 N/mm ²							
Stähle < 1.100 N/mm ² Steels < 1.100 N/mm ² Acciai < 1.100 N/mm ²							
Stähle < 1.300 N/mm ² Steels < 1.300 N/mm ² Acciai < 1.300 N/mm ²							
Stähle > 45 HRC Steels > 45 HRC Acciai > 45 HRC							
Rostfreie Stähle < 850 N/mm ² Stainless steels < 850 N/mm ² Acciai inossidabili < 850 N/mm ²							
Rostfreie Stähle > 850 N/mm ² Stainless steels > 850 N/mm ² Acciai inossidabili > 850 N/mm ²							
Grauguss, Temperguss Cast iron, malleable cast iron Ghisa grigia, ghisa malleabile							
Titan- und Titanlegierung Titanium and titanium alloys Titanio e leghe di Titanio							
Kupfer, Messing Copper, brass Rame, ottone							
Aluminium Aluminium Alluminio							
Kunststoffe Plastics Materie plastiche							

D **Übersicht**
VHM-Fräser

E **Overview**
Solid carbide
milling cutters

I **Sommario**
Frese in metallo
duro integrale

Entgrater / Deburring mills / Frese a smussare		Vor- u. Rückwärtsentgrater / Forward and reverse deburring mills / Frese per sbavatura reversibili	Einzahnfräser / 1-flute end mills / Frese monoelica				Konturenfräser / Contour end mills / Frese a contornare	
DIN 6527			WN					
N 90°	N 90°	N	W	W	W	W	W	W
4-6	4-6	4	1	1	1	1		2
			30°	30°	30°	30°		
DIN 6535-HB	DIN 6535-HB	DIN 6535-HA	DIN 6535-HA	DIN 6535-HA	DIN 6535-HA	DIN 6535-HA	d1=d2	d1=d2
	ALUNIT®	ALUNIT-S®						
4-16	4-16	3-12	2-12	1-6	2-12	2-12	6-14	2-14
7755	7757	6507	6205	6935	6495	6215	7976	7986
191	191	192	192	193	194	195	196	197

VHM-Fräser
Solid carbide milling cutters
Frese in metallo duro integrale

D VHM-Schaftfräser
kurz, Zweischneider

E Solid carbide end mills
short series, two flutes

I Frese frontali MDI
serie corta, 2 taglienti

Einsatzbereich:
Empfohlen zum Fräsen von Werkstoffen mit mittlerer bis hoher Festigkeit bis ca. 1.300 N/mm². Zum Bohren und anschließenden Längs- sowie Passnutenfräsen.

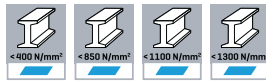

Range of application:
Recommended for milling in materials with medium and high tensile strength up to 1.300 N/mm². For drilling continued by horizontal milling with exact tolerances.



Impiego:
Adatte per fresatura di materiali di media ed alta resistenza fino a 1.300 N/mm². Foratura dal pieno e successiva fresatura di scanalature.



ALUNIT®

d1 _{h10} mm	d2 _{h6} mm	l1 mm	l2 mm		Z	Code 6015 Art.-Nr.	Code 6017 Art.-Nr.
1	1	38	5		2	0 6015001001 00	0 6017001001 00
1,5	1,5	38	5		2	0 6015001501 00	0 6017001501 00
2	2	38	8	0,04	2	0 6015002001 00	0 6017002001 00
2,5	2,5	38	8	0,05	2	0 6015002501 00	0 6017002501 00
3	3	38	12	0,05	2	0 6015003001 00	0 6017003001 00
3,5	3,5	40	12	0,05	2	0 6015003501 00	0 6017003501 00
4	4	40	12	0,06	2	0 6015004001 00	0 6017004001 00
4,5	4,5	50	14	0,06	2	0 6015004501 00	0 6017004501 00
5	5	50	14	0,06	2	0 6015005001 00	0 6017005001 00
6	6	50	16	0,08	2	0 6015006001 00	0 6017006001 00
7	7	60	20	0,10	2	0 6015007001 00	0 6017007001 00
8	8	63	20	0,10	2	0 6015008001 00	0 6017008001 00
9	9	67	20	0,12	2	0 6015009001 00	0 6017009001 00
10	10	72	22	0,15	2	0 6015010001 00	0 6017010001 00
12	12	73	22	0,15	2	0 6015012001 00	0 6017012001 00
14	14	75	25	0,20	2	0 6015014001 00	0 6017014001 00
16	16	82	28	0,20	2	0 6015016001 00	0 6017016001 00
18	18	84	28	0,20	2	0 6015018001 00	0 6017018001 00
20	20	104	35	0,25	2	0 6015020001 00	0 6017020001 00

D VHM-Schaftfräser für Aluminium
kurz, Zweischneider

Einsatzbereich:
Empfohlen zum Fräsen in Aluminium und Aluminiumlegierungen, Kunststoffen, Kupferlegierungen und NE-Metallen.



E Solid carbide end mills for aluminium
short series, two flutes

Range of application:
Recommended for milling aluminium and aluminium-alloys, plastics copper-alloys and non-ferrous metals.

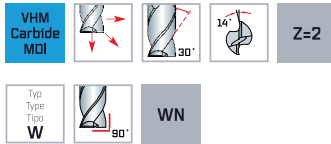

I Frese frontali MDI per alluminio
serie corta, 2 taglienti

Impiego:
Adatte per fresatura di alluminio, leghe di alluminio, materie plastiche, leghe di rame e materiali non ferrosi.



d1 _{h10} mm	d2 _{h6} mm	l1 mm	l2 mm	Z	Code 6915 Art.-Nr.
1	1	38	5	2	0 6915001001 00
1,5	1,5	38	5	2	0 6915001501 00
2	2	38	8	2	0 6915002001 00
2,5	2,5	38	8	2	0 6915002501 00
3	3	38	12	2	0 6915003001 00
4	4	40	12	2	0 6915004001 00
5	5	50	14	2	0 6915005001 00
6	6	50	16	2	0 6915006001 00
8	8	63	20	2	0 6915008001 00
10	10	72	22	2	0 6915010001 00
12	12	73	22	2	0 6915012001 00
14	14	75	25	2	0 6915014001 00
16	16	82	28	2	0 6915016001 00
18	18	84	28	2	0 6915018001 00
20	20	104	35	2	0 6915020001 00



VHM-Fräser
Solid carbide milling cutters
Frese in metallo duro integrale

D VHM-Schaftfräser
lang, Zweischneider

Einsatzbereich:
Empfohlen zum Fräsen von Werkstoffen mit mittlerer bis hoher Festigkeit bis ca. 1.300 N/mm². Zum Bohren und anschließenden Längs- sowie Passnutenfräsen.

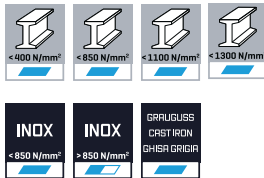

E Solid carbide end mills
long series, two flutes

Range of application:
Recommended for milling in materials with medium and high tensile strength up to 1.300 N/mm². For drilling continued by horizontal milling with exact tolerances.

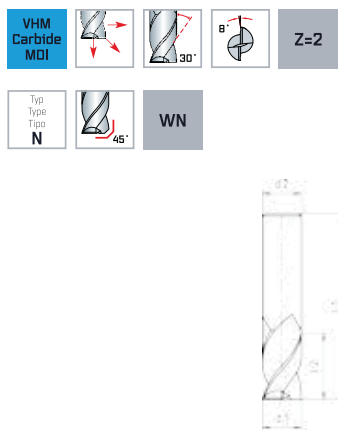

I Frese frontali MDI
serie lunga, 2 taglienti

Impiego:
Adatte per fresatura di materiali di media ed alta resistenza fino a 1.300 N/mm². Foratura dal pieno e successiva fresatura di scanalature.



ALLUNIT®

d1 _{h10} mm	d2 _{h6} mm	l1 mm	l2 mm		Z	Code 6025 Art.-Nr.	Code 6027 Art.-Nr.
3	3	60	25	0,05	2	0 6025003001 00	0 6027003001 00
4	4	60	25	0,06	2	0 6025004001 00	0 6027004001 00
5	5	70	30	0,06	2	0 6025005001 00	0 6027005001 00
6	6	70	30	0,08	2	0 6025006001 00	0 6027006001 00
8	8	80	35	0,10	2	0 6025008001 00	0 6027008001 00
10	10	100	45	0,15	2	0 6025010001 00	0 6027010001 00
12	12	100	45	0,15	2	0 6025012001 00	0 6027012001 00
12	12	150	75	0,15	2	0 6025012101 00	0 6027012101 00

D VHM-Schaftfräser
kurz, Dreischneider

Einsatzbereich:
Empfohlen zum Fräsen von Werkstoffen mit mittlerer bis hoher Festigkeit bis ca. 1.300 N/mm². Zum Bohren und anschließenden Längs- sowie Passnutenfräsen.



E Solid carbide end mills
short series, three flutes

Range of application:
Recommended for milling in materials with medium and high tensile strength up to 1.300 N/mm². For drilling continued by horizontal milling with exact tolerances.

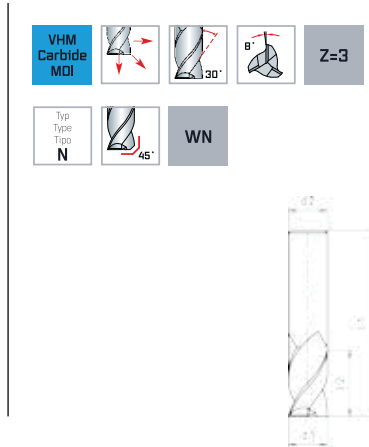

I Frese frontali MDI
serie corta, 3 taglienti

Impiego:
Adatte per fresatura di materiali di media ed alta resistenza fino a 1.300 N/mm². Foratura dal pieno e successiva fresatura di scanalature.



d1 _{h10} mm	d2 _{h6} mm	l1 mm	l2 mm		Z	Code 6055 Art.-Nr.	Code 6057 Art.-Nr.
1	1	38	5		3	0 6055001001 00	0 6057001001 00
1,5	1,5	38	5		3	0 6055001501 00	0 6057001501 00
2	2	38	8	0,04	3	0 6055002001 00	0 6057002001 00
2,5	2,5	38	8	0,05	3	0 6055002501 00	0 6057002501 00
3	3	38	12	0,05	3	0 6055003001 00	0 6057003001 00
3,5	3,5	40	12	0,05	3	0 6055003501 00	0 6057003501 00
4	4	40	12	0,06	3	0 6055004001 00	0 6057004001 00
4,5	4,5	50	14	0,06	3	0 6055004501 00	0 6057004501 00
5	5	50	14	0,06	3	0 6055005001 00	0 6057005001 00
6	6	50	16	0,08	3	0 6055006001 00	0 6057006001 00
7	7	60	20	0,10	3	0 6055007001 00	0 6057007001 00
8	8	63	20	0,10	3	0 6055008001 00	0 6057008001 00
9	9	67	20	0,12	3	0 6055009001 00	0 6057009001 00
10	10	72	22	0,15	3	0 6055010001 00	0 6057010001 00
12	12	73	22	0,15	3	0 6055012001 00	0 6057012001 00
14	14	75	25	0,20	3	0 6055014001 00	0 6057014001 00
16	16	82	28	0,20	3	0 6055016001 00	0 6057016001 00
18	18	84	28	0,20	3	0 6055018001 00	0 6057018001 00
20	20	104	35	0,25	3	0 6055020001 00	0 6057020001 00

VHM-Fräser
 Solid carbide milling cutters
 Frese in metallo duro integrale

D VHM-Schaftfräser
lang, Dreischneider

Einsatzbereich:
Empfohlen zum Fräsen von Werkstoffen mit mittlerer bis hoher Festigkeit bis ca. 1.300 N/mm². Zum Bohren und anschließenden Längs- sowie Passnutenfräsen.



E Solid carbide end mills
long series, three flutes

Range of application:
Recommended for milling in materials with medium and high tensile strength up to 1.300 N/mm². For drilling continued by horizontal milling with exact tolerances.

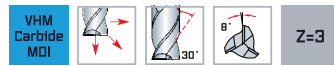

I Frese frontali MDI
serie lunga, 3 taglienti

Impiego:
Adatte per fresatura di materiali di media ed alta resistenza fino a 1.300 N/mm². Foratura dal pieno e successiva fresatura di scanalature.



ALUNIT®

d1 _{h10} mm	d2 _{h6} mm	l1 mm	l2 mm		Z	Code 6065 Art.-Nr.	Code 6067 Art.-Nr.
3	3	60	25	0,05	3	0 6065003001 00	0 6067003001 00
4	4	60	25	0,06	3	0 6065004001 00	0 6067004001 00
5	5	70	30	0,06	3	0 6065005001 00	0 6067005001 00
6	6	70	30	0,08	3	0 6065006001 00	0 6067006001 00
8	8	80	35	0,10	3	0 6065008001 00	0 6067008001 00
10	10	100	45	0,15	3	0 6065010001 00	0 6067010001 00
12	12	100	45	0,15	3	0 6065012001 00	0 6067012001 00
12	12	150	75	0,15	3	0 6065012101 00	
14	14	100	45	0,20	3	0 6065014001 00	0 6067014001 00
14	14	150	75	0,20	3	0 6065014101 00	
16	16	100	45	0,20	3	0 6065016001 00	0 6067016001 00
16	16	150	75	0,20	3	0 6065016101 00	
18	18	100	45	0,20	3	0 6065018001 00	0 6067018001 00
18	18	150	75	0,20	3	0 6065018101 00	
20	20	125	55	0,25	3	0 6065020001 00	0 6067020001 00
20	20	150	75	0,25	3	0 6065020101 00	

D VHM-Schaftfräser
kurz, Vierschneider

Einsatzbereich:

Empfohlen zum Fräsen von Werkstoffen mit mittlerer bis hoher Festigkeit. Fräsen von Nuten mit größerer Bohrtiefe, exakten Passungen, ebenso zum Stirn- und Umfangfräsen geeignet. Hoher Zerspanungsleistung und große Laufruhe ergeben exzellente Oberflächengüte.

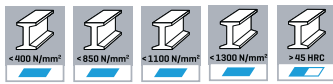

E Solid carbide end mills
short series, four flutes

Range of application:

Recommended for milling in materials with medium and high tensile strength. Milling of slots with large depth, accurate fits as well as face and surface milling. High cutting performance in chipping and a smooth run result an excellent surface.



I Frese frontali MDI
serie corta, 4 taglianti

Impiego:

Adatte per fresatura di materiali di media ed alta resistenza. Fresatura di scanalature profonde, con accoppiamenti precisi, anche per fresatura frontale e tangenziale. Elevato rendimento, silenziosità di passata, eccellente finitura della superficie.



ALUNIT®

d1 _{h10} mm	d2 _{h6} mm	l1 mm	l2 mm		Z	Code 6075 Art.-Nr.	Code 6077 Art.-Nr.
1	1	38	5		4	0 6075001001 00	0 6077001001 00
1,5	1,5	38	5		4	0 6075001501 00	0 6077001501 00
2	2	38	8	0,04	4	0 6075002001 00	0 6077002001 00
2,5	2,5	38	8	0,05	4	0 6075002501 00	0 6077002501 00
3	3	38	12	0,05	4	0 6075003001 00	0 6077003001 00
3,5	3,5	40	12	0,05	4	0 6075003501 00	0 6077003501 00
4	4	40	12	0,06	4	0 6075004001 00	0 6077004001 00
4,5	4,5	50	14	0,06	4	0 6075004501 00	0 6077004501 00
5	5	50	14	0,06	4	0 6075005001 00	0 6077005001 00
6	6	50	16	0,08	4	0 6075006001 00	0 6077006001 00
7	7	60	20	0,10	4	0 6075007001 00	0 6077007001 00
8	8	63	20	0,10	4	0 6075008001 00	0 6077008001 00
9	9	67	20	0,12	4	0 6075009001 00	0 6077009001 00
10	10	72	22	0,15	4	0 6075010001 00	0 6077010001 00
12	12	73	22	0,15	4	0 6075012001 00	0 6077012001 00
14	14	75	25	0,20	4	0 6075014001 00	0 6077014001 00
16	16	82	28	0,20	4	0 6075016001 00	0 6077016001 00
18	18	84	28	0,20	4	0 6075018001 00	0 6077018001 00
20	20	104	35	0,25	4	0 6075020001 00	0 6077020001 00



VHM-Fräser
Solid carbide milling cutters
Frese in metallo duro integrale

D VHM-Schaftfräser
lang, Vierschneider

Einsatzbereich:

Zum Schlichten mit hoher Zerspanungsleistung bei gleichzeitig exzellenter Oberfläche von Stählen mit mittlerer bis hoher Festigkeit (z.B. Bau-, Einsatz-, Vergütungsstähle); NE-Metalle, rost- und säurebeständige Stähle. Bevorzugt Gleichlaufräsen.

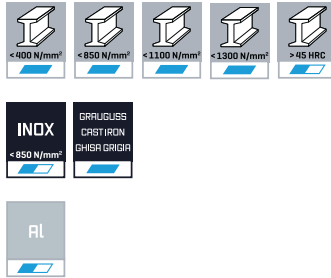

E Solid carbide end mills
long series, four flutes

Range of application:

Finishing with high cutting performance and excellent surface on steels with medium to high tensile strength (for example structural, case-hardening, heat-treatable steels); non-ferrous metals, stainless and acid resistant steels. Climb milling preferred.

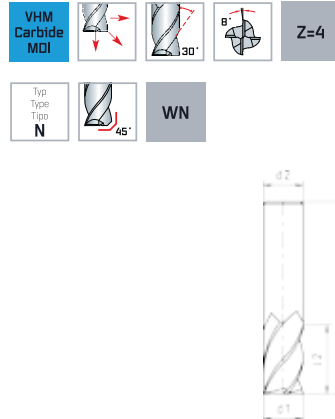

I Frese frontali MDI
serie lunga, 4 taglienti

Impiego:

Adatte per finitura ad alto rendimento realizzato di ottima superficie, in acciai di media fino ad elevata resistenza (es. acciai bonificati), materiali non ferrosi, acciai inox e resistenti agli acidi. Consigliata fresatura concorde.



d1 = d2

ALLUNIT®

d1 _{h10} mm	d2 _{h6} mm	l1 mm	l2 mm		Z	Code 6087 Art.-Nr.
3	3	60	25	0,05	4	0 6087003001 00
4	4	60	25	0,06	4	0 6087004001 00
5	5	70	30	0,06	4	0 6087005001 00
6	6	70	30	0,08	4	0 6087006001 00
8	8	80	35	0,10	4	0 6087008001 00
10	10	100	45	0,15	4	0 6087010001 00
12	12	100	45	0,15	4	0 6087012001 00
12	12	150	75	0,15	4	0 6087012101 00
14	14	100	45	0,20	4	0 6087014001 00
14	14	150	75	0,20	4	0 6087014101 00
16	16	100	45	0,20	4	0 6087016001 00
16	16	150	75	0,20	4	0 6087016101 00
18	18	100	45	0,20	4	0 6087018001 00
18	18	150	75	0,20	4	0 6087018101 00
20	20	125	55	0,25	4	0 6087020001 00
20	20	150	75	0,25	4	0 6087020101 00
25	25	125	55	0,30	4	0 6087025001 00
25	25	150	75	0,30	4	0 6087025101 00

D VHM-Schaftfräser

lang, Dreischneider, DIN 6527L, mit verstärktem Schaft

Einsatzbereich:

Empfohlen zum Fräsen von Werkstoffen mit mittlerer bis hoher Festigkeit. Fräsen von Nuten mit größerer Bohrtiefe, genauen Passungen, ebenso zum Stirn- und Umfangfräsen geeignet. Hohe Zerspanungsleistung und große Laufruhe ergeben exzellente Oberflächengüte.

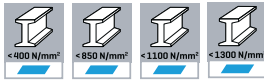

E Solid carbide end mills

long series, three flutes, DIN 6527L, with reinforced shank

Range of application:

Recommended for milling in materials with medium/high tensile strength. Milling of slots with large depth, accurate fits as well as face and surface milling. High cutting performance in chipping and a smooth run result in an excellent surface.

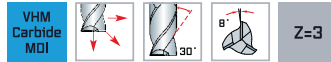

I Frese frontali MDI

serie lunga, 3 taglienti, DIN 6527L, codolo rinforzato

Impiego:

Adatte per fresatura di materiali di media ed alta resistenza. Fresatura di scanalature profonde, con accoppiamenti precisi, anche per fresatura frontale e tangenziale. Elevato rendimento, silenziosità di passata, eccellente finitura della superficie.



ALLUNIT®

d1 _{h10} mm	d1 _{h6} mm	l1 mm	l2 mm		Z	Code 7657 Art.-Nr.
2	6	50	6	0,04	3	0 7657002001 00
2,5	6	50	6	0,05	3	0 7657002501 00
3	6	57	7	0,05	3	0 7657003001 00
3,5	6	57	7	0,05	3	0 7657003501 00
4	6	57	8	0,06	3	0 7657004001 00
4,5	6	57	8	0,06	3	0 7657004501 00
5	6	57	10	0,06	3	0 7657005001 00
5,5	6	57	10	0,08	3	0 7657005501 00
6	6	57	10	0,08	3	0 7657006001 00
7	8	63	13	0,10	3	0 7657007001 00
8	8	63	16	0,10	3	0 7657008001 00
9	10	72	16	0,12	3	0 7657009001 00
10	10	72	19	0,15	3	0 7657010001 00
11	12	83	22	0,15	3	0 7657011001 00
12	12	83	22	0,15	3	0 7657012001 00



VHM-Fräser
Solid carbide milling cutters
Frese in metallo duro integrale

D VHM-Schaftfräser
lang, Vierschneider,
DIN 6527L, mit verstärktem
Schaft

Einsatzbereich:

Zum Schlichten mit hoher Zerspanungsleistung bei gleichzeitig exzellenter Oberfläche von Stählen mit mittlerer bis hoher Festigkeit (z.B. Bau-, Einsatz-, Vergütungsstähle); NE-Metalle, rost- und säurebeständige Stähle. Bevorzugt Gleichlaufräsen.

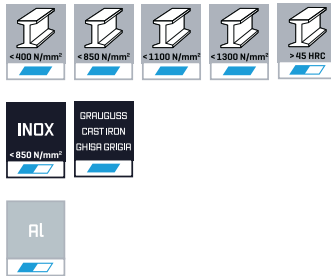

E Solid carbide end mills
long series, four flutes,
DIN 6527L, with reinforced
shank

Range of application:

Finishing with high cutting performance and excellent surface on steels with medium to high tensile strength (for example structural, case-hardening, heat-treatable steels); non-ferrous metals, stainless and acid resistant steels. Climb milling preferred.

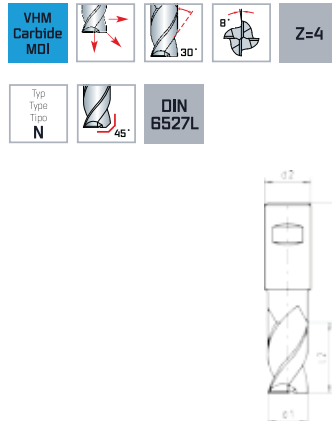

I Frese frontali MDI
serie lunga, 4 taglienti,
DIN 6527L, codolo rinforzato

Impiego:

Adatte per finitura ad alto rendimento realizzato di ottima superficie, in acciai di media fino ad elevata resistenza (es. acciai bonificati), materiali non ferrosi, acciai inox e resistenti agli acidi. Consigliata fresatura concorde.



ALLUNIT®

d1 _{h10} mm	d2 _{h6} mm	l1 mm	l2 mm		Z	Code 7677 Art.-Nr.
2	6	50	7	0,04	4	0 7677002001 00
2,5	6	50	7	0,05	4	0 7677002501 00
3	6	57	8	0,05	4	0 7677003001 00
3,5	6	57	10	0,05	4	0 7677003501 00
4	6	57	11	0,06	4	0 7677004001 00
4,5	6	57	11	0,06	4	0 7677004501 00
5	6	57	13	0,06	4	0 7677005001 00
5,5	6	57	13	0,08	4	0 7677005501 00
6	6	57	13	0,08	4	0 7677006001 00
6,5	8	63	16	0,08	4	0 7677006501 00
7	8	63	16	0,10	4	0 7677007001 00
7,5	8	63	16	0,10	4	0 7677007501 00
8	8	63	19	0,10	4	0 7677008001 00
8,5	10	72	19	0,12	4	0 7677008501 00
9	10	72	19	0,12	4	0 7677009001 00
9,5	10	72	22	0,12	4	0 7677009501 00
10	10	72	22	0,15	4	0 7677010001 00
11	12	83	26	0,15	4	0 7677011001 00
12	12	83	26	0,15	4	0 7677012001 00
13	14	83	26	0,18	4	0 7677013001 00
14	14	83	26	0,20	4	0 7677014001 00
15	16	92	32	0,20	4	0 7677015001 00
16	16	92	32	0,20	4	0 7677016001 00
18	18	92	32	0,20	4	0 7677018001 00
20	20	104	38	0,25	4	0 7677020001 00

D VHM-Schaftfräser
lang, scharfkantig,
Vierschneider, DIN 6527L,
mit verstärktem Schaft

Einsatzbereich:

Zum Schlichten mit hoher Zerspanungsleistung bei gleichzeitig exzellenter Oberfläche von Stählen mit mittlerer bis hoher Festigkeit (z.B. Bau-, Einsatz-, Vergütungsstähle); NE-Metalle, rost- und säurebeständige Stähle. Bevorzugt Gleichlaufräsen.

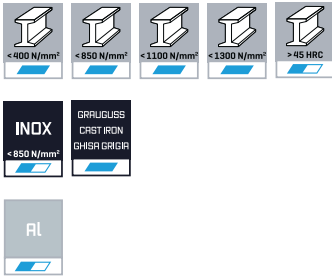

E Solid carbide end mills
long series, sharp cutting
edges, four flutes, DIN 6527L,
with reinforced shank

Range of application:

Finishing with high cutting performance and excellent surface on steels with medium to high tensile strength (for example structural, case-hardening, heat-treatable steels); non-ferrous metals, stainless and acid resistant steels. Climb milling preferred.

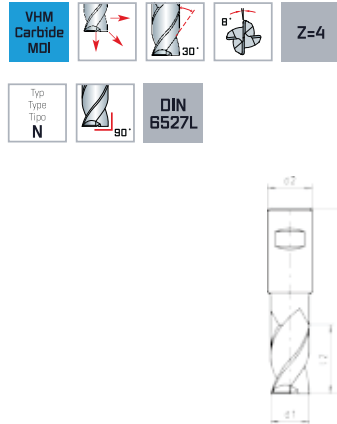

I Frese frontali MDI
serie lunga, spigoli tagliente
affilati, 4 taglienti, DIN 6527L,
codolo rinforzato

Impiego:

Adatte per finitura ad alto rendimento realizzo di ottima superficie, in acciai di media fino ad elevata resistenza (es. acciai bonificati), materiali non ferrosi, acciai inox e resistenti agli acidi. Consigliata fresatura concorde.

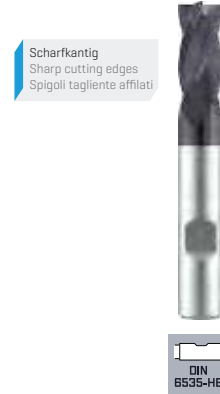

ALLUNIT®

d1 _{h10} mm	d2 _{h6} mm	l1 mm	l2 mm	Z	Code 7617 Art.-Nr.
3	6	57	8	4	0 7617003001 00
4	6	57	11	4	0 7617004001 00
5	6	57	13	4	0 7617005001 00
6	6	57	13	4	0 7617006001 00
8	8	63	19	4	0 7617008001 00
10	10	72	22	4	0 7617010001 00
12	12	83	26	4	0 7617012001 00
16	16	92	32	4	0 7617016001 00
20	20	104	38	4	0 7617020001 00

VHM-Fräser
 Solid carbide milling cutters
 Frese in metallo duro integrale

D VHM-Schrupfräser 20°
lang, DIN 6527L

Einsatzbereich:

VHM-Hochleistungs-Schrupfräser, besonders geeignet für alle Stahlwerkstoffe bis 1.400 N/mm², höherfeste rostfreie Stähle, Grauguss sowie kurzspanende Aluminiumwerkstoffe und Aluminiumguss. Hohe Zerspanungsleistung.

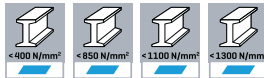

E Solid carbide roughing end mills 20°
long series, DIN 6527L

Range of application:

Solid carbide high performance roughing cutter, especially suitable for all kind of steels up to 1.400 N/mm², higher tensile stainless steels, grey cast iron as well as short chipping aluminium and aluminium cast. High cutting performance.

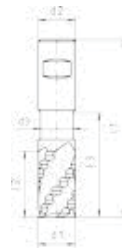
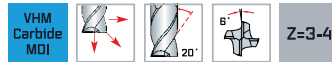

I Frese frontali MDI a sgrossare 20°
serie lunga, DIN 6527L

Impiego:

Fresa a sgrossare MDI ad alto rendimento particolarmente adatta per tutti i tipi di acciaio fino a 1.400 N/mm², acciai inossidabili ad alta resistenza e ghisa ed inoltre per alluminio a truciolo corto ed alluminio pressofuso. Alto rendimento di taglio.



ALLUNIT-S®

d1 _{h10} mm	d2 _{h6} mm	d3 mm	l1 mm	l2 mm	l3 mm		Z	Code 7047 Art.-Nr.
4	6	3,8	57	11	18	0,10	3	0 7047004001 00
5	6	4,7	57	13	20	0,20	3	0 7047005001 00
6	6	5,6	57	13	20	0,20	3	0 7047006001 00
8	8	7,5	63	19	25	0,20	3	0 7047008001 00
10	10	9,5	72	22	30	0,20	4	0 7047010001 00
12	12	11,5	83	26	36	0,35	4	0 7047012001 00
14	14	13,5	83	26	36	0,35	4	0 7047014001 00
16	16	15,5	92	32	42	0,35	4	0 7047016001 00
20	20	19,5	104	38	52	0,35	4	0 7047020001 00

ab Ø 6 mm: HR Schrupprofil / as of Ø 6 mm: HR roughing profile / da Ø 6 mm: Profilo di sgrassatura HR
Ø 4 und 5 mm: Spanbrecher / Ø 4 and 5 mm: Chip breaker / Ø 4 e 5 mm: Rompitruciolo

D VHM-Schrupfräser 30°
lang, DIN 6527L

E Solid carbide roughing end mills 30°
long series, DIN 6527L

I Frese frontali MDI a sgrossare 30°
serie lunga, DIN 6527L

Einsatzbereich:

Universeller Anwendungsbereich bei Werkstoffen mit mittlerer bis hoher Festigkeit (ca. 900–1.400 N/mm²), z.B. Einsatz-, Vergütungsstähle, Werkzeugstahl legiert, vergütet, NE-Metalle, hochwärmfeste Werkstoffe sowie Gusseisen und Gusslegierungen.

Range of application:

Universal range of applications on materials of medium strength up to high tensile strength (~ 900–1.400 N/mm²), for example case-hardening, heat-treatable steels, alloyed tool steels; hardened and tempered non-ferrous metals, high temperature materials as well as cast iron and alloyed cast iron.

Impiego:

Impiego universale con materiali a media ed alta resistenza (~ 900–1.400 N/mm²), ad esempio acciai da cementazione, acciai bonificati, acciai legati da cementazione, metalli non ferrosi temprati, materiali ad alta temperatura ed inoltre ghisa e leghe di ghisa.

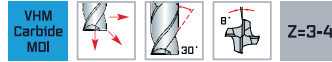
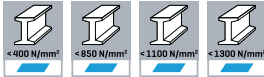

ALLUNIT®

d1 _{h10} mm	d2 _{h6} mm	l1 mm	l2 mm		Z	Code 7027 Art.-Nr.
3	6	57	8	0,10	3	0 7027003001 00
4	6	57	11	0,10	3	0 7027004001 00
5	6	57	13	0,20	3	0 7027005001 00
6	6	57	13	0,20	3	0 7027006001 00
8	8	63	19	0,20	3	0 7027008001 00
10	10	72	22	0,35	4	0 7027010001 00
12	12	83	26	0,35	4	0 7027012001 00
14	14	83	26	0,35	4	0 7027014001 00
16	16	92	32	0,35	4	0 7027016001 00
18	18	92	32	0,35	4	0 7027018001 00
20	20	104	38	0,35	4	0 7027020001 00

ab Ø 6 mm: HR Schrappprofil / as of Ø 6 mm: HR roughing profile / da Ø 6 mm: Profilo di sgrossatura HR
Ø 3,4 und 5 mm: Spanbrecher / Ø 3,4 and 5 mm: Chip breaker / Ø 3,4 e 5 mm: Romptruciolo

VHM-Fräser
 Solid carbide milling cutters
 Frese in metallo duro integrale

D VHM-Schrupfräser 45°
lang, DIN 6527L

Einsatzbereich:

VHM-Hochleistungs-Schrupfräser, besonders geeignet für Stahlwerkstoffe von 500 bis 1.400 N/mm², rostfreie Stähle, Grauguss und Titan. Hohe Zerspanungsleistung bei geringen Antriebsleistungen = MTC.

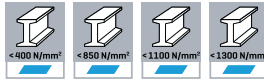

E Solid carbide roughing end mills 45°
long series, DIN 6527L

Range of application:

Solid carbide high performance roughing cutter, especially suitable for steels from 500 to 1.400 N/mm², stainless steels, grey cast iron and titanium. High cutting performance at less drive power = MTC.

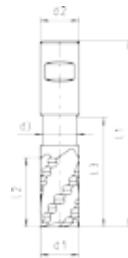
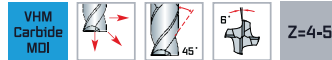

I Frese frontali MDI a sgrossare 45°
serie lunga, DIN 6527L

Impiego:

Fresa a sgrossare MDI ad alto rendimento particolarmente adatta per acciai da 500 a 1.400 N/mm², acciai inossidabili, ghisa e titanio. Alto rendimento di taglio con minor potenza assorbita = MTC.



ALLUNIT-S®

d1 _{h10} mm	d2 _{h6} mm	d3 mm	l1 mm	l2 mm	l3 mm		Z	Code 7087 Art.-Nr.
6	6	5,6	57	13	20	0,20	4	0 7087006001 00
8	8	7,5	63	19	25	0,20	4	0 7087008001 00
10	10	9,5	72	22	30	0,20	4	0 7087010001 00
12	12	11,5	83	26	36	0,35	4	0 7087012001 00
16	16	15,5	92	32	42	0,35	5	0 7087016001 00
20	20	19,5	104	38	52	0,35	5	0 7087020001 00

D VHM-Schaftfräser
mit verstärktem Schaft,
Zweischneider

Einsatzbereich:

Empfohlen zum Fräsen von Werkstoffen mit mittleren und hohen Festigkeiten. Bohren auf volle Tiefe und Längsfräsen mit genauen Passungen.

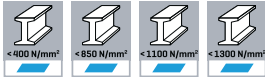

E Solid carbide end mills
with reinforced straight
shank, two flutes

Range of application:

Recommended for milling in materials with medium and high tensile strength. Vertical cutting to full depth and horizontal cutting with exact tolerances.



I Frese frontali MDI
codolo rinforzato, serie corta,
2 taglienti

Impiego:

Adatte per fresatura di materiali di media ed alta resistenza. Foratura dal pieno e fresatura di scanalature con accoppiamenti precisi.



d1 _{h10} mm	d2 _{h6} mm	l1 mm	l2 mm	Z	Code 6615 Art.-Nr.
1	6	40	4	2	0 6615001001 00
1,5	6	40	4	2	0 6615001501 00
2	6	40	6	2	0 6615002001 00
2,5	6	40	6	2	0 6615002501 00
3	6	40	7	2	0 6615003001 00
3,5	6	40	7	2	0 6615003501 00
4	6	40	8	2	0 6615004001 00
4,5	6	40	8	2	0 6615004501 00
5	6	40	10	2	0 6615005001 00
5,5	6	40	10	2	0 6615005501 00
6	6	40	10	2	0 6615006001 00

VHM-Fräser
Solid carbide milling cutters
Frese in metallo duro integrale

D VHM-Schaftfräser
mit verstärktem Schaft,
Dreischneider

Einsatzbereich:

Empfohlen zum Fräsen von Werkstoffen mit mittlerer bis hoher Festigkeit. Fräsen von Nuten mit größerer Bohrtiefe, genauen Passungen, ebenso zum Stirn- und Umfangfräsen geeignet. Hohe Zerspanungsleistung und große Laufruhe ergeben exzellente Oberflächengüte.

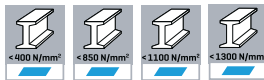

E Solid carbide end mills
with reinforced straight
shank, three flutes

Range of application:

Recommended for milling in materials with medium/high tensile strength. Milling of slots with large depth, accurate fits as well as face and surface milling. High cutting performance in chipping and a smooth run result in an excellent surface.



I Frese frontali MDI
codolo rinforzato, serie corta,
3 taglianti

Impiego:

Adatte per fresatura di materiali di media ed alta resistenza. Fresatura di scanalature profonde, con accoppiamenti precisi, anche per fresatura frontale e tangenziale. Elevato rendimento, silenziosità di passata, eccellente finitura della superficie.



ALUNIT®

d1 _{h10} mm	d2 _{h6} mm	l1 mm	l2 mm	Z	Code 6315 Art.-Nr.	Code 6317 Art.-Nr.
1	6	40	4	3	0 6315001001 00	0 6317001001 00
1,5	6	40	4	3	0 6315001501 00	0 6317001501 00
2	6	40	6	3	0 6315002001 00	0 6317002001 00
2,5	6	40	6	3	0 6315002501 00	0 6317002501 00
3	6	40	7	3	0 6315003001 00	0 6317003001 00
3,5	6	40	7	3	0 6315003501 00	0 6317003501 00
4	6	40	8	3	0 6315004001 00	0 6317004001 00
4,5	6	40	8	3	0 6315004501 00	0 6317004501 00
5	6	40	10	3	0 6315005001 00	0 6317005001 00
5,5	6	40	10	3	0 6315005501 00	0 6317005501 00
6	6	40	10	3	0 6315006001 00	0 6317006001 00

D VHM-Schaftfräser
mit verstärktem Schaft,
Vierschneider

Einsatzbereich:

Empfohlen zum Fräsen von Werkstoffen mit mittlerer bis hoher Festigkeit. Fräsen von Nuten mit größerer Bohrtiefe, exakten Passungen, ebenso zum Stirn- und Umfangfräsen geeignet. Hoher Zerspanungsleistung und große Laufruhe ergeben exzellente Oberflächengüte.

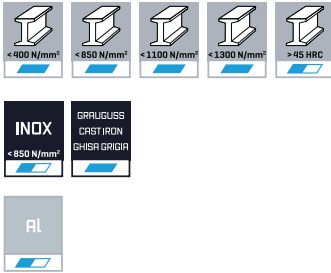

E Solid carbide end mills
with reinforced straight
shank, four flutes

Range of application:

Recommended for milling in materials with medium and high tensile strength. Milling of slots with large depth, accurate fits as well as face and surface milling. High cutting performance in chipping and a smooth run result an excellent surface.

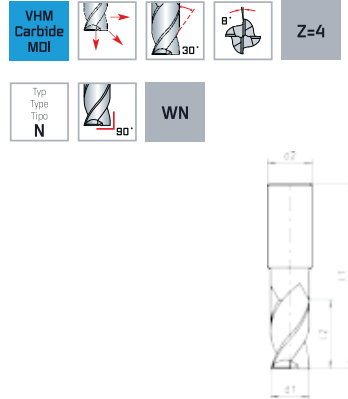

I Frese frontali MDI,
codolo rinforzato, serie corta,
4 taglienti

Impiego:

Adatte per fresatura di materiali di media ed alta resistenza. Fresatura di scanalature profonde, con accoppiamenti precisi, anche per fresatura frontale e tangenziale. Elevato rendimento, silenziosità di passata, eccellente finitura della superficie.



ALUNIT®

d1 _{h10} mm	d2 _{h6} mm	l1 mm	l2 mm	Z	Code 6517 Art.-Nr.
1	6	40	4	4	0 6517001001 00
1,5	6	40	4	4	0 6517001501 00
2	6	40	6	4	0 6517002001 00
2,5	6	40	6	4	0 6517002501 00
3	6	40	7	4	0 6517003001 00
3,5	6	40	7	4	0 6517003501 00
4	6	40	8	4	0 6517004001 00
4,5	6	40	8	4	0 6517004501 00
5	6	40	10	4	0 6517005001 00
5,5	6	40	10	4	0 6517005501 00
6	6	40	10	4	0 6517006001 00



VHM-Fräser
Solid carbide milling cutters
Frese in metallo duro integrale

D VHM-Miniaturfräser
mit verstärktem Schaft,
kurz, Zweischneider

Einsatzbereich:

Empfohlen zum Fräsen von Werkstoffen mit mittlerer bis hoher Festigkeit bis ca. 1.300 N/mm². Zum Bohren und anschließenden Längsfräsen, besonders zum Kopierfräsen geeignet.



E Solid carbide mini end mills
with reinforced straight shank,
short series, two flutes

Range of application:

Recommended for milling in materials with medium and high tensile strength up to 1.300 N/mm². For drilling continued by horizontal milling, especially suited for copy milling.

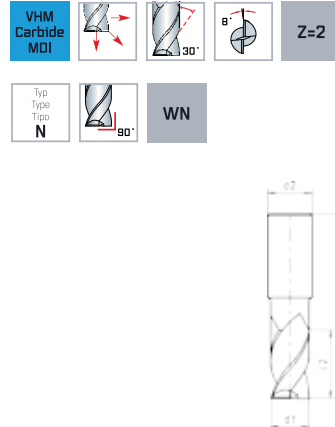

I Frese in miniatura MDI
codolo rinforzato, serie corta,
2 taglianti

Impiego:

Adatte per fresatura di materiali di media ed alta resistenza fino a 1.300 N/mm². Foratura dal pieno e successiva fresatura di scanalature, particolarmente indicate per fresatura a copiare.



d1 _{h10} mm	d2 _{h6} mm	l1 mm	l2 mm	Z	Code 6245 Art.-Nr.
0,4	3	38	1,5	2	0 6245000401 00
0,5	3	38	1,5	2	0 6245000501 00
0,6	3	38	2	2	0 6245000601 00
0,7	3	38	3	2	0 6245000701 00
0,8	3	38	3	2	0 6245000801 00
0,9	3	38	3	2	0 6245000901 00
1	3	38	3	2	0 6245001001 00
1,5	3	38	5	2	0 6245001501 00
2	3	38	6	2	0 6245002001 00
2,5	3	38	7	2	0 6245002501 00
3	3	38	8	2	0 6245003001 00

D VHM-Miniaturfräser
mit verstärktem Schaft,
lang, Dreischneider

E Solid carbide mini end mills
with reinforced straight shank,
long series, three flutes

I Frese in miniatura MDI
codolo rinforzato, serie lunga,
3 taglianti

Einsatzbereich:

Empfohlen zum Fräsen von Werkstoffen mit mittlerer bis hoher Festigkeit bis ca. 1.300 N/mm². Zum Bohren und anschließenden Längsfräsen, besonders zum Kopierfräsen geeignet.

Range of application:

Recommended for milling in materials with medium and high tensile strength up to 1.300 N/mm². For drilling continued by horizontal milling, especially suited for copy milling.

Impiego:

Adatte per fresatura di materiali di media ed alta resistenza fino a 1.300 N/mm². Foratura dal pieno e successiva fresatura di scanalature, particolarmente indicate per fresatura a copiare.

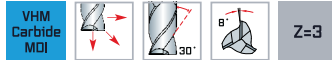
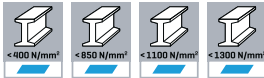

ALLUNIT®

d1 _{h10} mm	d2 _{h6} mm	l1 mm	l2 mm	Z	Code 6477 Art.-Nr.
1	3	38	4	3	0 6477001001 00
1,5	3	38	6	3	0 6477001501 00
2	3	38	9	3	0 6477002001 00
2,5	3	38	12	3	0 6477002501 00
3	3	38	12	3	0 6477003001 00



VHM-Fräser
Solid carbide milling cutters
Frese in metallo duro integrale

D VHM-Radiusfräser
kurz, Zweischneider

Einsatzbereich:
Empfohlen zum Fräsen von Werkstoffen mit mittlerer bis hoher Festigkeit. Besonders zum Kopierfräsen geeignet.



E Solid carbide ball nose end mills
short series, two flutes

Range of application:
Recommended for milling materials with medium/high tensile strength. Especially suited for copy milling.

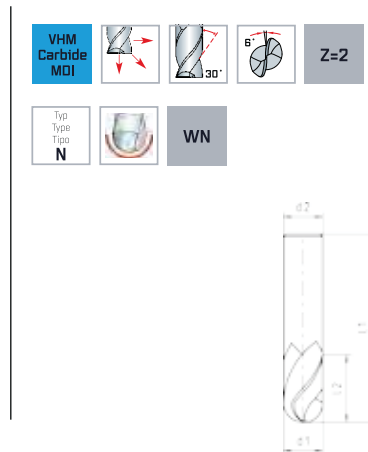

I Frese cilindriche raggiate MDI
serie corta, 2 taglienti

Impiego:
Adatte per fresatura di materiali di media ed alta resistenza, particolarmente indicate per fresatura a copiare.



d1 _{h10} mm	d2 _{h6} mm	l1 mm	l2 mm	Z	Code 7525 Art.-Nr.	Code 7527 Art.-Nr.
1	1	38	5	2	0 7525001001 00	0 7527001001 00
1,5	1,5	38	5	2	0 7525001501 00	0 7527001501 00
2	2	38	8	2	0 7525002001 00	0 7527002001 00
2,5	2,5	38	8	2	0 7525002501 00	0 7527002501 00
3	3	38	12	2	0 7525003001 00	0 7527003001 00
3,5	3,5	40	12	2	0 7525003501 00	0 7527003501 00
4	4	40	12	2	0 7525004001 00	0 7527004001 00
4,5	4,5	50	14	2	0 7525004501 00	0 7527004501 00
5	5	50	14	2	0 7525005001 00	0 7527005001 00
6	6	50	16	2	0 7525006001 00	0 7527006001 00
8	8	63	20	2	0 7525008001 00	0 7527008001 00
10	10	72	22	2	0 7525010001 00	0 7527010001 00
12	12	73	22	2	0 7525012001 00	0 7527012001 00
14	14	75	25	2	0 7525014001 00	0 7527014001 00
16	16	82	28	2	0 7525016001 00	0 7527016001 00
18	18	84	28	2	0 7525018001 00	0 7527018001 00
20	20	104	35	2	0 7525020001 00	0 7527020001 00

D VHM-Radiusfräser für Aluminium

kurz, Zweischneider

Einsatzbereich:

Empfohlen zum Kopierfräsen in Aluminium und Aluminiumlegierungen, Kunststoffen, Kupferlegierungen und NE-Metallen.



E Solid carbide ball nose end mills for aluminium

short series, two flutes

Range of application:

Recommended for copy milling aluminium and aluminium-alloys, plastics copper-alloys and non-ferrous metals.



I Frese ragiate MDI per alluminio

serie corta, 2 taglienti

Impiego:

Adatte per fresatura di alluminio, leghe di alluminio, materie plastiche, leghe di rame e materiali non ferrosi.



d1 _{h10} mm	d2 _{h6} mm	l1 mm	l2 mm	Z	Code 6925 Art.-Nr.
1	1	38	5	2	0 6925001001 00
2	2	38	8	2	0 6925002001 00
3	3	38	12	2	0 6925003001 00
4	4	40	12	2	0 6925004001 00
5	5	50	14	2	0 6925005001 00
6	6	50	16	2	0 6925006001 00
8	8	63	20	2	0 6925008001 00
10	10	72	22	2	0 6925010001 00
12	12	73	22	2	0 6925012001 00



VHM-Fräser
Solid carbide milling cutters
Frese in metallo duro integrale

D VHM-Radiusfräser
lang, Zweischneider

Einsatzbereich:
Empfohlen zum Fräsen von Werkstoffen mit mittlerer bis hoher Festigkeit. Besonders zum Kopierfräsen geeignet.



E Solid carbide ball nose end mills
long series, two flutes

Range of application:
Recommended for milling materials with medium/high tensile strength. Especially suited for copy milling.

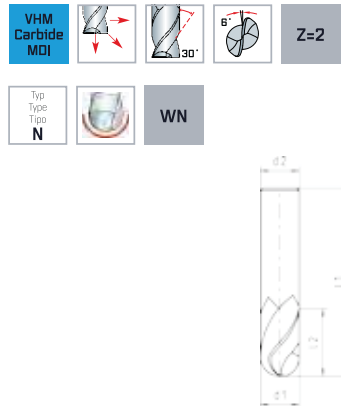

I Frese cilindriche raggiate MDI
serie lunga, 2 taglienti

Impiego:
Adatte per fresatura di materiali di media ed alta resistenza, particolarmente indicate per fresatura a copiare.



d1 _{h10} mm	d2 _{h6} mm	l1 mm	l2 mm	Z	Code 7535 Art.-Nr.
3	3	60	25	2	0 7535003001 00
4	4	60	25	2	0 7535004001 00
5	5	70	30	2	0 7535005001 00
6	6	70	30	2	0 7535006001 00
8	8	80	35	2	0 7535008001 00
10	10	100	45	2	0 7535010001 00
12	12	100	45	2	0 7535012001 00

D VHM-Radiusfräser
kurz, Dreischneider

E Solid carbide ball nose end mills
short series, three flutes

I Frese cilindriche raggiate MDI
serie corta, 3 taglienti

Einsatzbereich:

Empfohlen zum Fräsen von Werkstoffen mit mittlerer bis hoher Festigkeit. Besonders zum Kopierfräsen geeignet.

Range of application:

Recommended for milling materials with medium/high tensile strength. Especially suited for copy milling.

Impiego:

Adatte per fresatura di materiali di media ed alta resistenza, particolarmente indicate per fresatura a copiare.

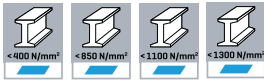

ALUNIT®

d1 _{h10} mm	d2 _{h6} mm	l1 mm	l2 mm	Z	Code 7555 Art.-Nr.	Code 7557 Art.-Nr.
1	1	38	5	3	0 7555001001 00	0 7557001001 00
1,5	1,5	38	5	3	0 7555001501 00	0 7557001501 00
2	2	38	8	3	0 7555002001 00	0 7557002001 00
2,5	2,5	38	8	3	0 7555002501 00	0 7557002501 00
3	3	38	12	3	0 7555003001 00	0 7557003001 00
3,5	3,5	40	12	3	0 7555003501 00	0 7557003501 00
4	4	40	12	3	0 7555004001 00	0 7557004001 00
4,5	4,5	50	14	3	0 7555004501 00	0 7557004501 00
5	5	50	14	3	0 7555005001 00	0 7557005001 00
6	6	50	16	3	0 7555006001 00	0 7557006001 00
8	8	63	20	3	0 7555008001 00	0 7557008001 00
10	10	72	22	3	0 7555010001 00	0 7557010001 00
12	12	73	22	3	0 7555012001 00	0 7557012001 00
14	14	75	25	3	0 7555014001 00	0 7557014001 00
16	16	82	28	3	0 7555016001 00	0 7557016001 00
18	18	84	28	3	0 7555018001 00	0 7557018001 00
20	20	104	35	3	0 7555020001 00	0 7557020001 00



VHM-Fräser
Solid carbide milling cutters
Frese in metallo duro integrale

D VHM-Radiusfräser
kurz, Vierschneider

Einsatzbereich:
Empfohlen zum Fräsen von Werkstoffen mit mittlerer bis hoher Festigkeit. Besonders zum Kopierfräsen geeignet.

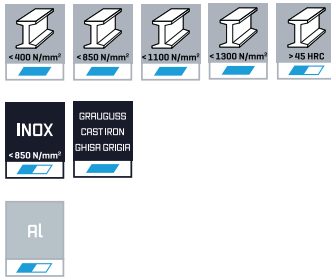

E Solid carbide ball nose end mills
short series, four flutes

Range of application:
Recommended for milling materials with medium/high tensile strength. Especially suited for copy milling.

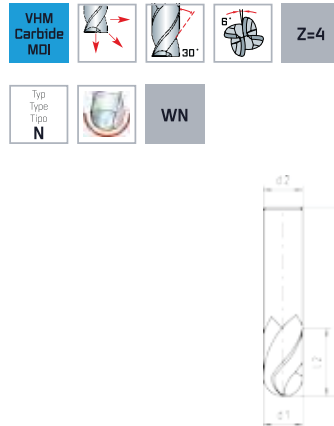

I Frese cilindriche raggiate MDI
serie corta, 4 taglienti

Impiego:
Adatte per fresatura di materiali di media ed alta resistenza, particolarmente indicate per fresatura a copiare.



d1 _{h10} mm	d2 _{h6} mm	l1 mm	l2 mm	Z	Code 7075 Art.-Nr.	Code 7077 Art.-Nr.
1	1	38	5	4	0 7075001001 00	0 7077001001 00
1,5	1,5	38	5	4	0 7075001501 00	0 7077001501 00
2	2	38	8	4	0 7075002001 00	0 7077002001 00
2,5	2,5	38	8	4	0 7075002501 00	0 7077002501 00
3	3	38	12	4	0 7075003001 00	0 7077003001 00
3,5	3,5	40	12	4	0 7075003501 00	0 7077003501 00
4	4	40	12	4	0 7075004001 00	0 7077004001 00
4,5	4,5	50	14	4	0 7075004501 00	0 7077004501 00
5	5	50	14	4	0 7075005001 00	0 7077005001 00
6	6	50	16	4	0 7075006001 00	0 7077006001 00
8	8	63	20	4	0 7075008001 00	0 7077008001 00
10	10	72	22	4	0 7075010001 00	0 7077010001 00
12	12	73	22	4	0 7075012001 00	0 7077012001 00
14	14	75	25	4	0 7075014001 00	0 7077014001 00
16	16	82	28	4	0 7075016001 00	0 7077016001 00
18	18	84	28	4	0 7075018001 00	0 7077018001 00
20	20	104	35	4	0 7075020001 00	0 7077020001 00

D VHM-Radiusfräser
mit verstärktem Schaft,
lang Zweischneider,
DIN 6527L

Einsatzbereich:
Empfohlen zum Fräsen von Werkstoffen mit
mittlerer bis hoher Festigkeit. Besonders
zum Kopierfräsen geeignet.



E Solid carbide ball nose end mills
with reinforced shank,
long series, two flutes,
DIN 6527L

Range of application:
Recommended for milling materials with medi-
um/high tensile strength. Especially suited for
copy milling.

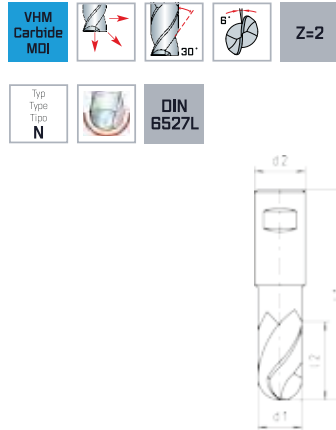

I Frese cilindriche raggiate MDI
codolo rinforzato, serie lunga,
2 taglienti, DIN 6527L

Impiego:
Adatte per fresatura di materiali di media ed alta
resistenza, particolarmente indicate per fresatura
a copiare.



ALLUNIT®

d1 _{h10} mm	d2 _{h6} mm	l1 mm	l2 mm	Z	Code 7517 Art.-Nr.
2	6	50	6	2	0 7517002001 00
3	6	57	7	2	0 7517003001 00
4	6	57	8	2	0 7517004001 00
5	6	57	10	2	0 7517005001 00
6	6	57	10	2	0 7517006001 00
7	8	63	13	2	0 7517007001 00
8	8	63	16	2	0 7517008001 00
9	10	72	16	2	0 7517009001 00
10	10	72	19	2	0 7517010001 00
12	12	83	22	2	0 7517012001 00

VHM-Fräser
Solid carbide milling cutters
Frese in metallo duro integrale

D VHM-Miniatur-Radiusfräser
mit verstärktem Schaft,
kurz, Zweischneider

Einsatzbereich:
Empfohlen zum Fräsen von Werkstoffen mit
mittlerer bis hoher Festigkeit. Besonders
zum Kopierfräsen geeignet.



**E Solid carbide
mini ball nose end mills**
with reinforced shank,
short series, two flutes

Range of application:
Recommended for milling materials with medi-
um/high tensile strength. Especially suited for
copy milling.

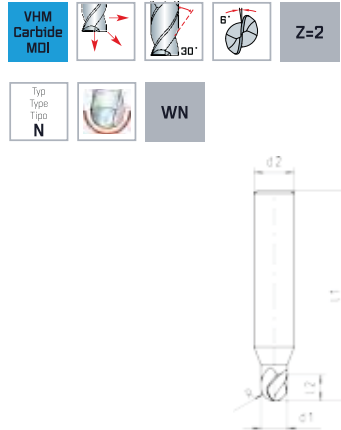

**I Frese in miniatura
raggiate MDI**
codolo rinforzato, serie corta,
2 taglienti

Impiego:
Adatte per fresatura di materiali di media ed alta
resistenza, particolarmente indicate per fresatura
a copiare.



d1 _{h10} mm	d2 _{h6} mm	l1 mm	l2 mm	R mm	Z	Code 6345 Art.-Nr.
0,4	3	38	1,5	0,2	2	0 6345000401 00
0,5	3	38	1,5	0,25	2	0 6345000501 00
0,6	3	38	2	0,3	2	0 6345000601 00
0,7	3	38	3	0,35	2	0 6345000701 00
0,8	3	38	3	0,4	2	0 6345000801 00
0,9	3	38	3	0,45	2	0 6345000901 00
1	3	38	3	0,5	2	0 6345001001 00
1,5	3	38	5	0,75	2	0 6345001501 00
2	3	38	6	1	2	0 6345002001 00
2,5	3	38	7	1,25	2	0 6345002501 00
3	3	38	8	1,5	2	0 6345003001 00

D VHM-Miniatur Radiusfräser
mit verstärktem Schaft,
lang, Vierschneider

Einsatzbereich:
Empfohlen zum Fräsen von Werkstoffen mit mittlerer bis hoher Festigkeit. Besonders zum Kopierfräsen geeignet.

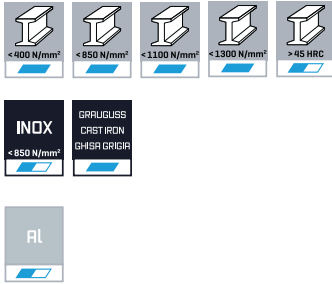

E Solid carbide mini ball nose end mills
with reinforced shank,
long series, four flutes

Range of application:
Recommended for milling materials with medium/high tensile strength. Especially suited for copy milling.

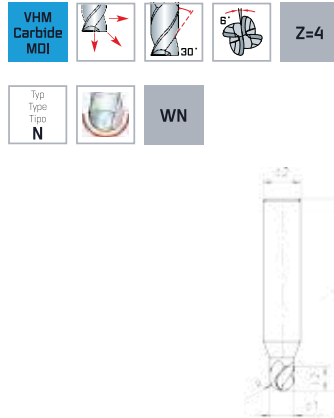

I Frese in miniatura raggiate MDI
codolo rinforzato, serie lunga,
4 taglienti

Impiego:
Adatte per fresatura di materiali di media ed alta resistenza, particolarmente indicate per fresatura a copiare.



ALLUNIT®

d1 _{h10} mm	d2 _{h6} mm	l1 mm	l2 mm	R mm	Z	Code 6387 Art.-Nr.
1	3	38	4	0,5	4	0 6387001001 00
1,5	3	38	6	0,75	4	0 6387001501 00
2	3	38	9	1	4	0 6387002001 00
2,5	3	38	12	1,25	4	0 6387002501 00
3	3	38	12	1,5	4	0 6387003001 00

VHM-Fräser
Solid carbide milling cutters
Frese in metallo duro integrale

D VHM-Miniaturfräser
Zweischneider

E Solid carbide mini end mills
two flutes

I Frese in miniatura MDI
2 taglienti

Einsatzbereich:
Empfohlen zum Fräsen von Werkstoffen mit mittleren und hohen Festigkeiten sowie zur HSC-Bearbeitung.

Range of application:
Recommended for milling materials with medium and high tensile strength, HSC-milling.

Impiego:
Adatte per fresatura di materiali di media ed alta resistenza, anche per alta velocità HSC.

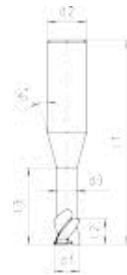
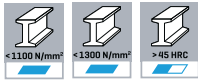

ALLUNIT®

d1 _{h10} mm	d2 _{h6} mm	d3 mm	l1 mm	l2 mm	l3 mm	Z	Code 6257 Art.-Nr.
0,4	3	0,35	50	0,6	5	2	0 6257000401 00
0,5	3	0,45	50	0,7	6	2	0 6257000501 00
0,6	3	0,55	50	0,9	6	2	0 6257000601 00
0,7	3	0,65	50	0,8	7	2	0 6257000701 00
0,8	3	0,75	50	1,2	8	2	0 6257000801 00
0,9	3	0,85	50	1,3	9	2	0 6257000901 00
1	3	0,95	50	1,5	12	2	0 6257001001 00
1,2	3	1,15	50	1,8	12	2	0 6257001201 00
1,4	3	1,35	50	2,1	16	2	0 6257001401 00
1,5	3	1,45	50	2,3	20	2	0 6257001501 00
1,6	3	1,55	50	2,4	20	2	0 6257001601 00
1,8	3	1,75	50	2,7	20	2	0 6257001801 00
2	3	1,95	50	3	20	2	0 6257002001 00
2,5	3	2,45	50	3,7	20	2	0 6257002501 00
3	3	2,95	50	4	20	2	0 6257003001 00

D VHM-Miniatur-Radius-Fräser

Zweischneider

Einsatzbereich:

Für die Bearbeitung von Werkstoffen mit mittlerer bis hoher Festigkeit. Besonders zum HSC-Kopierfräsen geeignet.

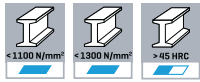

E Solid carbide mini ball nose end mills

two flutes

Range of application:

For milling materials with medium/high tensile strength. Especially suited for HSC-copy milling.

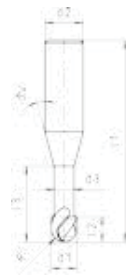

I Frese in miniatura con punta semisferica MDI

2 taglienti

Impiego:

Adatte per fresatura di materiali di media ed alta resistenza, serie alta velocità HSC particolarmente indicate per fresatura a copiare..



ALLUNIT®

d1 _{h10} mm	d2 _{h6} mm	d3 mm	l1 mm	l2 mm	l3 mm	R mm	Z	Code 6297 Art.-Nr.
0,4	3	0,35	50	0,6	5	0,2	2	0 6297000401 00
0,5	3	0,45	50	0,7	6	0,25	2	0 6297000501 00
0,6	3	0,55	50	0,9	6	0,3	2	0 6297000601 00
0,7	3	0,65	50	0,8	7	0,35	2	0 6297000701 00
0,8	3	0,75	50	1,2	8	0,4	2	0 6297000801 00
0,9	3	0,85	50	1,3	9	0,45	2	0 6297000901 00
1	3	0,95	50	1,5	12	0,5	2	0 6297001001 00
1,2	3	1,15	50	1,8	12	0,6	2	0 6297001201 00
1,4	3	1,35	50	2,1	16	0,6	2	0 6297001401 00
1,5	3	1,45	50	2,3	20	0,75	2	0 6297001501 00
1,6	3	1,55	50	2,4	20	0,8	2	0 6297001601 00
1,8	3	1,75	50	2,7	20	0,8	2	0 6297001801 00
2	3	1,95	50	3	20	1	2	0 6297002001 00
2,5	3	2,45	50	3,7	20	1,25	2	0 6297002501 00
3	3	2,95	50	4	20	1,5	2	0 6297003001 00

R = ± 0,01 mm



VHM-Fräser
Solid carbide milling cutters
Frese in metallo duro integrale

D VHM-Viertelrund-Profil-Fräser

E Solid carbide quarter circle cutters

I Frese a profilo raggiato MDI

Einsatzbereich:
Empfohlen zum Fräsen von Bau-, Einsatz- und Vergütungsstählen mit normaler Festigkeit bis 1.100 N/mm² sowie für kurzspanende NE-Metalle.

Range of application:
Recommended for milling in construction steels, tempered steels and cementation steels with standard tensile strength up to 1.100 N/mm² and short-chipping of non-ferrous metals.

Impiego:
Adatte per lavorazioni di acciai da costruzione, acciai da cementazione, acciai bonificati con R fino a 1.100 N/mm², e di materiali non ferrosi a truciolo corto.

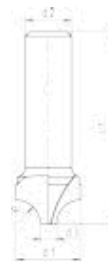
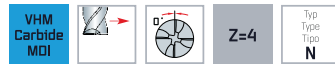
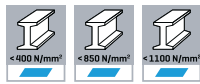

ALLUNIT®

R mm	d1 _{h10} mm	d2 _{h6} mm	d3 mm	l1 mm	Z	Code 6415 Art.-Nr.	Code 6417 Art.-Nr.
1	8	8	6	64	4	0 6415001001 00	0 6417001001 00
1,5	8	8	5	64	4	0 6415001501 00	0 6417001501 00
2	8	8	4	64	4	0 6415002001 00	0 6417002001 00
2,5	10	10	5	67	4	0 6415002501 00	0 6417002501 00
3	10	10	4	67	4	0 6415003001 00	0 6417003001 00
3,5	12	12	5	74	4	0 6415003501 00	0 6417003501 00
4	12	12	4	74	4	0 6415004001 00	0 6417004001 00
5	16	16	6	83	4	0 6415005001 00	0 6417005001 00
6	16	16	4	83	4	0 6415006001 00	0 6417006001 00
8	26,5	20	10,5	85	4	0 6415008001 00	0 6417008001 00
10	32	20	12	85	4	0 6415010001 00	0 6417010001 00
12	38	20	14	90	4	0 6415012001 00	0 6417012001 00

≤ R 6 = VHM / Solid carbide / MDI
> R 8 = nur VHM-Kopf / only solid carbide cutting part / parte taglienti metallo duro integrale

D VHM-Multifräser, 90°

Einsatzbereich:

Universeller Anwendungsbereich, besonders geeignet zum Fräsen, Anfasen, Entgraten, Anbohren und Bohren.

E Solid carbide multi end mills 90°

Range of application:

Universal range of application, especially suited for milling, chamfering, deburring, pre-drilling and drilling.

I Multi frese MDI, 90°

Impiego:

Adatte per impieghi universali, particolarmente raccomandate per fresatura, lavorazioni, smussatura, perforazione e foratura.

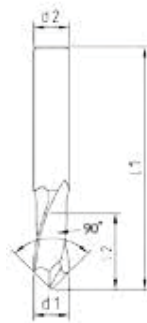

ALLUNIT®

d1 _{h9} mm	d2 _{h6} mm	l1 mm	l2 mm	α	Z	Code 6397 Art.-Nr.
3	6	50	6	90°	2	0 6397003001 00
4	6	54	8	90°	2	0 6397004001 00
5	6	57	10	90°	2	0 6397005001 00
6	6	57	12	90°	2	0 6397006001 00
8	8	63	16	90°	2	0 6397008001 00
10	10	72	18	90°	2	0 6397010001 00
12	12	83	20	90°	2	0 6397012001 00



VHM-Fräser
Solid carbide milling cutters
Frese in metallo duro integrale

D VHM-Entgrater, 60°

Einsatzbereich:

Universeller Anwendungsbereich, besonders geeignet zum Anfasen und Entgraten sowie Konturarbeiten.

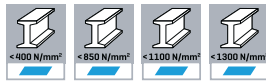

E Solid carbide deburring mills, 60°

Range of application:

Universal range of application, especially suited for chamfering and deburring as well as contouring.



I Frese a smussare MDI, 60°

Impiego:

Adatte per impieghi universali, particolarmente raccomandate per lavorazioni di smussatura, sbavatura ed anche di contornatura.



ALUNIT®

d1 _{h10} mm	d2 _{h6} mm	l1 mm	Z	Code 7725 Art.-Nr.	Code 7727 Art.-Nr.
4	4	54	4	0 7725004001 00	0 7727004001 00
6	6	57	4	0 7725006001 00	0 7727006001 00
8	8	63	4	0 7725008001 00	0 7727008001 00
10	10	72	4	0 7725010001 00	0 7727010001 00
12	12	83	4	0 7725012001 00	0 7727012001 00
16	16	92	6	0 7725016001 00	0 7727016001 00

Ø 4 kein Weldon-Schaft / Ø 4 no weldon shaft / Ø 4 no gambo Weldon

D VHM-Entgrater, 90°

Einsatzbereich:
Universeller Anwendungsbereich, besonders geeignet zum Anfasen und Entgraten sowie Konturarbeiten.



E Solid carbide deburring mills, 90°

Range of application:
Universal range of application, especially suited for chamfering and deburring as well as contouring.

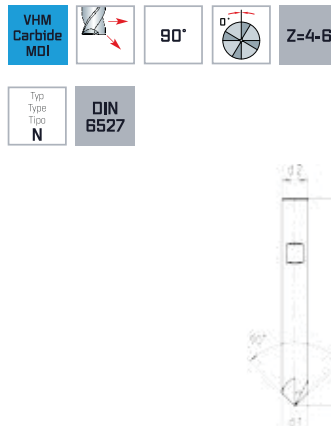

I Frese a smussare MDI, 90°

Impiego:
Adatte per impieghi universali, particolarmente raccomandate per lavorazioni di smussatura, sbavatura ed anche di contornatura.



ALUNIT®

d1 _{h10} mm	d2 _{h6} mm	l1 mm	Z	Code 7755 Art.-Nr.	Code 7757 Art.-Nr.
4	4	54	4	0 7755004001 00	0 7757004001 00
6	6	57	4	0 7755006001 00	0 7757006001 00
8	8	63	4	0 7755008001 00	0 7757008001 00
10	10	72	4	0 7755010001 00	0 7757010001 00
12	12	83	4	0 7755012001 00	0 7757012001 00
New 16	16	92	6	0 7755016001 00	0 7757016001 00

Ø 4 kein Weldon-Schaft / Ø 4 no weldon shaft / Ø 4 no gambo Weldon



VHM-Fräser
Solid carbide milling cutters
Frese in metallo duro integrale

D VHM Vor- und Rückwärtsentgrater, 2 x 90°

Einsatzbereich:
Universeller Anwendungsbereich, besonders geeignet zum Anfasen, Vor- und Rückwärtsentgraten sowie Konturarbeiten.



E Solid carbide forward and reverse deburring mills, 2 x 90°

Range of application:
Universal range of application, especially suited for chamfering, forward and reverse deburring as well as contouring.

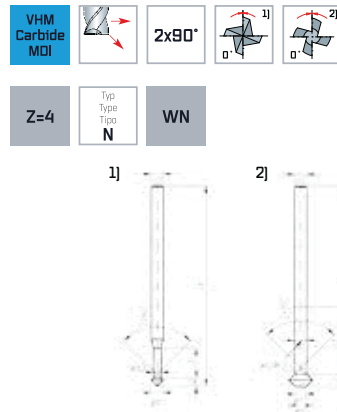

I Frese in metallo duro per sbavatura reversibili, 2 x 90°

Impiego:
Adatte per impieghi universali, particolarmente raccomandate per lavorazioni di smussatura, sbavatura reversibili ed anche di contornatura.



ALUNIT-S®

d1 _{h10} mm	d2 _{h6} mm	d3 mm	l1 mm	l2 mm	l3 mm	Z	Code 6507 Art.-Nr.
3	4	2,2	75	1,9	10	4	0 6507003001 00
4	4	2,9	75	2,5	15	4	0 6507004001 00
5	5	3,9	75	3,0	15	4	0 6507005001 00
6	6	3,9	100	4,0	15	4	0 6507006001 00
8	6	4,8	100	2,7	35	4	0 6507008001 00
10	6	4,7	100	4,7	33	4	0 6507010001 00
12	6	5,4	100	6,4	31	4	0 6507012001 00

1) d1: Ø 3 - 6 mm
2) d1: Ø 8 - 12 mm

D VHM-Einzahnfräser für Aluminium

Einsatzbereich:
Rechtsschneidend mit Rechtsdrall. Geeignet für die Bearbeitung von Aluminium und Aluminiumlegierungen.



E Solid carbide 1-flute end mills for aluminium

Range of application:
Right-hand cutting with right-hand spiral. Especially suited for cutting aluminium and aluminium-alloys.

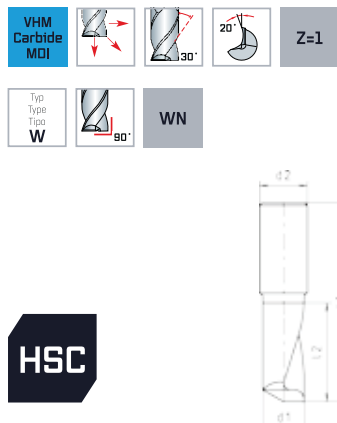

I Frese monoelica MDI per alluminio

Impiego:
Taglio destro con elica destra. Adatte per fresatura di alluminio e leghe di alluminio.



d1 _{h10} mm	d2 _{h6} mm	l1 mm	l2 mm	Z	Code 6205 Art.-Nr.
2	2	38	10	1	0 6205002001 00
2,5	2,5	38	12	1	0 6205002501 00
3	3	38	12	1	0 6205003001 00
4	4	40	15	1	0 6205004001 00
5	5	50	16	1	0 6205005001 00
6	6	50	18	1	0 6205006101 00
6	6	57	25	1	0 6205006201 00
8	8	63	22	1	0 6205008201 00
8	8	80	40	1	0 6205008401 00
10	10	72	30	1	0 6205010001 00
12	12	73	30	1	0 6205012001 00

D VHM-Einzahn-Miniatur-Fräser für Aluminium

Einsatzbereich:
Rechtsschneidend mit Rechtsdrill.
Geeignet für die Bearbeitung von Aluminium und Aluminiumlegierungen.



E Solid carbide 1-flute mini end mills for aluminium

Range of application:
Right-hand cutting with right-hand spiral.
Especially suited for cutting aluminium and aluminium-alloys.

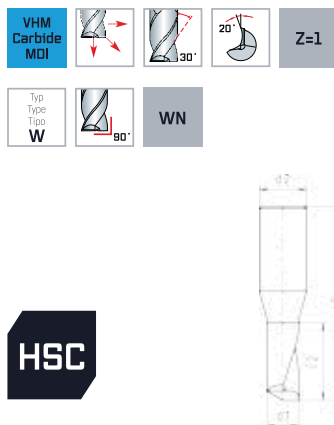

I Frese in miniatura monoelica MDI per alluminio

Impiego:
Taglio destro con elica destra. Adatte per fresatura di alluminio e leghe di alluminio.



DIN 6535-HR

VHM-Fräser
Solid carbide milling cutters
Frese in metallo duro integrale

d1 _{h10} mm	d2 _{h6} mm	l1 mm	l2 mm	Z	Code 6935 Art.-Nr.
1	6	40	5	1	0 6935001001 00
1,5	6	40	7	1	0 6935001501 00
2	6	40	7	1	0 6935002001 00
2,5	6	40	8	1	0 6935002501 00
3	6	40	8	1	0 6935003001 00
3,5	6	40	10	1	0 6935003501 00
4	6	40	10	1	0 6935004001 00
4,5	6	50	12	1	0 6935004501 00
5	6	50	12	1	0 6935005001 00
5,5	6	50	14	1	0 6935005501 00
6	6	50	14	1	0 6935006001 00

D VHM-Einzahnfräser für Kunststoffe, Rechtsschneidend mit Rechtsdrall

Einsatzbereich:
Geeignet für die Bearbeitung von sämtlichen Kunststoffen, glasfaserverstärkte Polyester und Graphit.



E Solid carbide 1-flute end mills for plastics, righthand cutting with righthand spiral

Range of application:
Especially suited for cutting all plastics, glass-fibre reinforced polyester as well as graphite.



I Frese monoelica MDI per materie plastiche, taglio destro elica destra

Impiego:
Adatte per fresatura di tutte le materie plastiche, poliesteri vetrosi, grafite.



d1 _{h10} mm	d2 _{h6} mm	l1 mm	l2 mm	Z	Code 6495 Art.-Nr.
2	2	38	10	1	0 6495002001 00
2,5	2,5	38	12	1	0 6495002501 00
3	3	38	12	1	0 6495003001 00
4	4	40	15	1	0 6495004001 00
5	5	50	16	1	0 6495005001 00
6	6	50	18	1	0 6495006001 00
6	6	57	25	1	0 6495006101 00
8	8	63	22	1	0 6495008001 00
8	8	80	40	1	0 6495008101 00
10	10	72	30	1	0 6495010001 00
12	12	73	30	1	0 6495012001 00

D VHM-Einzahnfräser für Kunststoffe,
Rechtsschneidend mit
Linksdrall

Einsatzbereich:
Geeignet für die Bearbeitung von sämtlichen Kunststoffen, glasfaserverstärkte Polyester und Grafit.



E Solid carbide 1-flute end mills for plastics,
righthand cutting with
lefthand spiral

Range of application:
Especially suited for cutting all plastics, glass-fibre reinforced polyester as well as graphite.



I Frese monoelica MDI per materie plastiche,
taglio destro elica destra

Impiego:
Adatte per fresatura di tutte le materie plastiche, poliesteri vetrosi, grafite.



d1 _{h10} mm	d2 _{h6} mm	l1 mm	l2 mm	Z	Code 6215 Art.-Nr.
2	2	38	10	1	0 6215002001 00
2,5	2,5	38	12	1	0 6215002501 00
3	3	38	12	1	0 6215003001 00
4	4	40	15	1	0 6215004001 00
5	5	50	16	1	0 6215005001 00
6	6	50	18	1	0 6215006001 00
6	6	57	25	1	0 6215006101 00
8	8	63	22	1	0 6215008001 00
8	8	80	40	1	0 6215008101 00
10	10	72	30	1	0 6215010001 00
12	12	73	30	1	0 6215012001 00



VHM-Fräser
Solid carbide milling cutters
Frese in metallo duro integrale

D VHM-Konturenfräser für
Kunststoffe,
mit Sitrnverzahnung

E Solid carbide contour end
mills for plastics,
with front cut

I Frese a contornare MDI per
materie plastiche,
taglienti frontali

Einsatzbereich:

Geeignet zum Besäumen und Umrissfräsen von faserverstärkten Kunststoffen „GFK“ und „CFK“.

Range of application:

Especially suitable for cutting glass-fibre and carbon-fibre-reinforced plastics „GFP“ and „CFP“.

Impiego:

Adatte per fresatura di contornatura fibre di vetro, plastica, gomma dura.

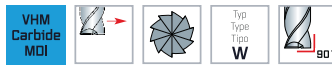

WN



d1 _{h10} mm	d2 _{h6} mm	l1 mm	l2 mm	Code 7976 Art.-Nr.
6	6	50	18	0 7976006001 00
6	6	57	25	0 7976006101 00
8	8	63	25	0 7976008001 00
8	8	80	40	0 7976008101 00
10	10	72	30	0 7976010001 00
12	12	73	30	0 7976012001 00
14	14	75	30	0 7976014001 00

D VHM-Konturenfräser für Kunststoffe, Zweischneider

E Solid carbide contour end mills for plastics, two flutes

I Frese a contornare MDI per materie plastiche, 2 taglienti

Einsatzbereich:

Geeignet zum Besäumen und Umrissfräsen von faserverstärkten Kunststoffen „GFK“ und „CFK“.

Range of application:

Especially suitable for cutting glass-fibre and carbon-fibre-reinforced plastics „GFP“ and „CFP“.

Impiego:

Adatte per fresatura di contornatura fibre di vetro, plastica, gomma dura.

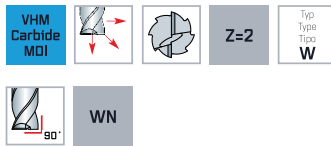

d1 = d2

d1 _{h10} mm	d2 _{h6} mm	l1 mm	l2 mm	Z	Code 7986 Art.-Nr.
2	2	38	10	2	0 7986002001 00
3	3	38	12	2	0 7986003001 00
4	4	40	15	2	0 7986004001 00
5	5	50	16	2	0 7986005001 00
6	6	50	18	2	0 7986006001 00
6	6	57	25	2	0 7986006101 00
8	8	63	25	2	0 7986008001 00
8	8	80	40	2	0 7986008101 00
10	10	72	30	2	0 7986010001 00
12	12	73	30	2	0 7986012001 00
14	14	75	30	2	0 7986014001 00



VHM-Fräser
Solid carbide milling cutters
Frese in metallo duro integrale